

[www.cais.eu](http://www.cais.eu)

CZECH REPUBLIC - SLOVAKIA - NEW ZEALAND - ISRAEL  
FINLAND - DANMARK - SLOVENIA - ROMANIA - CROATIA  
GERMANY - CANADA - UNITED KINGDOM - AUSTRIA - HUNGARY  
BULGARIA - SERBIA - LATVIA - LITHUANIA - ESTONIA - MOLDAVIA - BELARUS  
KALININGRAD REGION

CAIS





---

“CREATIVITY IS  
INTELLIGENCE  
HAVING FUN”

Albert Einstein –



# About Us

We are dedicated to making the best cantilever and sliding gate hardware. Since inception direction towards to the highest quality is our driving force. This can be seen with the dedication and passion of the workforce. This can be seen in the packaging. This can be seen in the care and attention to the smallest details. As it's this detail on hardware that can make all the difference in the lifespan of the product and the electric motors that power them.

Following extensive research and development CAIS is now in the enviable position of offering

the highest quality product available for the gate market. We have worked with a renowned BRNO UNIVERSITY OF TECHNOLOGY - FACULTY OF MECHANICAL ENGINEERING, looking at the way the load is transferred throughout the wheels, bearings and carriages whilst under stress of a moving gate.

The results surprised and inspired us to reinvent our product, to become more accurate and search intensively for a steel supplier that can match our ambitions.

We searched for galvanised steel that doesn't crack under rolling, we searched for steel of the correct tolerances and chemical composition.

We found all this and more with our German Supplier WUPPERMANN and created something very impressive.

CAIS also invested heavily in what is the heart of our company, a brand new roll forming line.

With uniquely, 18 large precision formed rollers that allow minute differences to be made until the rolling is perfectly straight and accurate to our own exact standards.





## State Of The Art Roll Forming Line

**Eighteen Roll Formers** - The best in the industry to remove the inset "memory" of the metal.

**Built in flying hole punch** - Punches a hole in the rail exactly every 400 mm.

**Slow rolling** - This means no heat during the production keeping the material where it is rolled with no "relaxation" of the product after.

## 25 Years of Innovation

Since 1992, it is only after 25 years that the culmination of this experience has produced the best production line for cantilever hardware in the world. The Roll Forming line in action, its unique in its precision and accuracy.

## Steel Stripe

Steel Strip must only be the best, which is why world renowned **Wupperman Steel** is the only supplier capable of the exacting standards we require. Galvanised stripe of exacting standards means that you can bolt our product only after you've galvanised your gate. So even if your gate is slightly bent. The rail won't be.

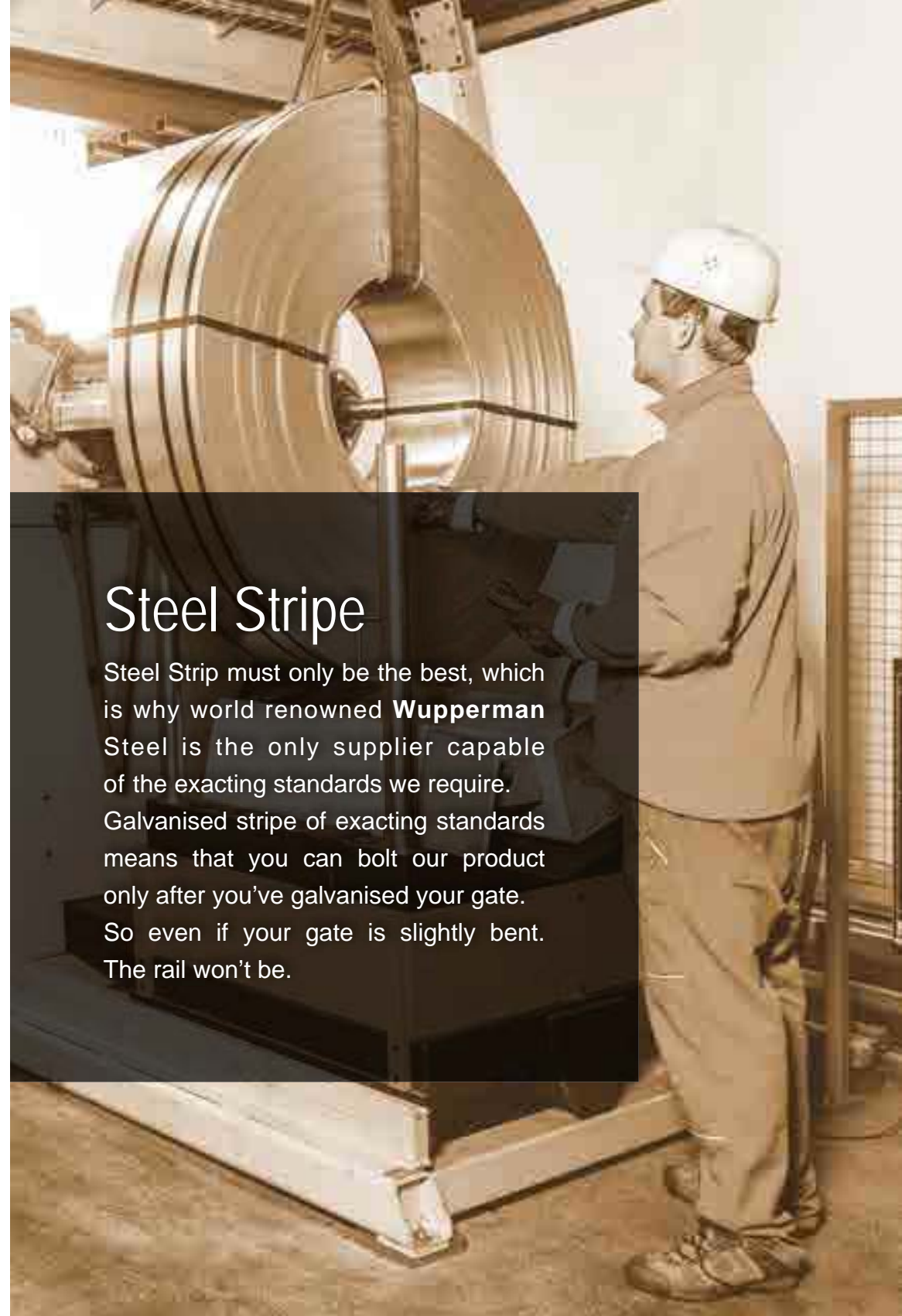

WE MANUFACTURE  
TO OUR STANDARDS  
NOT ASSEMBLE  
OTHERS

## Engineering Excellence Carriages

**Carriages** - Centre holes are milled not lasered.  
Only high strength certificated precision tool steel  
is used.

Wheels are riveted into position with just  
EXACTLY the right amount of pressure. This  
gives our carriage a trademark smoothness once  
the load is applied.



## Made in Czech Republic

The steel-making industry has a very long tradition in the Czech Republic and Czech steel products are well known the world over. Manufacturing methods affect the quality of steel products - this is why the raw materials and every single stage of the manufacturing process are carefully controlled, which is proof of the ability of Czech manufacturers to follow the latest trends and to use the latest technologies.

## Exclusive Dealership Network

We will be continuously expanding our Exclusive Dealership Network to better meet the needs of World Wide markets. Currently our Exclusive Dealers are successfully covering the territory of Czech Republic Slovakia - Belarus - New Zealand - Israel - Finland Denmark - Slovenia - Romania - Croatia Germany - Canada - United Kingdom Austria - Hungary - Bulgaria - Serbia - Latvia Lithuania - Estonia - Moldavia - Kaliningrad Region.



“THE IDEA IS  
NOT TO LIVE  
FOREVER,  
IT IS TO  
CREATE  
SOMETHING  
THAT WILL”

– Andy Warhol

WE NEVER STOP  
**INVESTING**  
WE NEVER STOP  
**IMPROVING**  
WE NEVER STOP  
**DOING**  
**SOMETHING**  
**NEW**



CZECH  
R&D



GERMAN  
STEEL

**FANUC**

JAPANESE  
ROBOTICS



PRODUCT  
DEVELOPMENT  
PROCESS





WE NEVER APOLOGISE  
FOR HAVING **HIGH STANDARDS**

---

TABLE OF CONTENTS



GB D F E P I DK NL N S FIN PL SK EE LT

CZ LV RO HR RUS SLO TR AR CHN MAL H IL BG KO SRB



OLD WAYS  
WON'T OPEN NEW DOORS

---

TABLE OF CONTENTS

**EA  
SY** **SE  
TS**



CAIS FOLLOW ME SET **16**



CAIS TWIN DRIVE SET **18**



CAIS CHEVRON SET **20**



CAIS HANGAR SET **22**



CAIS ALL IN ONE SET **24**

PATENT OFFICE  
PATENTED OFFICE PRIKRYL HAS  
REGISTERED AT INDUSTRIAL  
PROPERTY OFFICE THE UTILITY  
MODEL NUMBER 28617 FOR E-BOX  
CANTILEVER GATE, PRODUCED BY  
CAIS s.r.o.



CAIS  
INNOVATION

**NEW**

# CAIS FOLLOW ME SET 4.25

TWINNED TELESCOPIC  
CANTILEVER HARDWARE  
SPACE-SAVING FEATURE

FOLLOW ME 4.25

CODE: 1710900

	mm: kg	mm: kg	mm: kg	mm: kg	mm: kg	mm: kg	mm: kg
A	2750	3000	3250	3500	3750	4000	4250
backspace	2722	2930	3138	3347	3555	3763	3972
max. weight gate	325 kg	325 kg	325 kg	325 kg	325 kg	325 kg	325 kg
B	817	900	983	1067	1150	1233	1317
C	1217	1300	1383	1467	1550	1633	1717
D	200	200	200	200	200	200	200
G	2228	2415	2603	2790	2978	3165	3353
H	2622	2830	3038	3247	3455	3663	3872
J	270	270	270	270	270	270	270
K	383	445	508	570	633	695	758
L	4067	4400	4733	5067	5400	5733	6067

Valid for gate frame 60x40

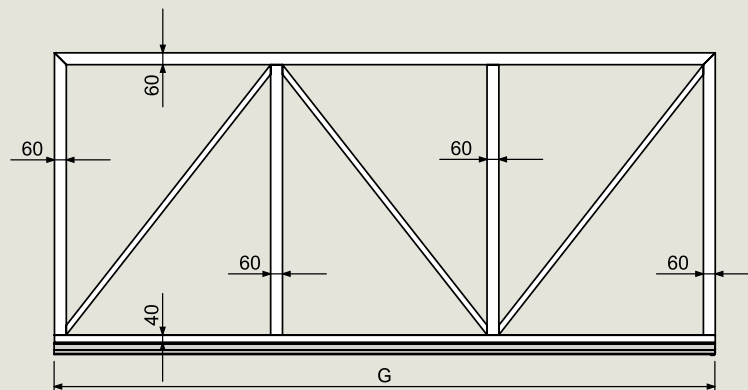

DOUBLE-QUICK TIME GATE OPERATOR CLOSING & OPENING



GALVANIZED INTERNAL EDGES



SPACE SAVING FEATURE - 36% TAILGATE SPACE



«C» TRACK SERIAL NO. 100% COMPATIBILITY CARRIAGE TESTED



EASY ASSEMBLING



GERMAN STEEL WUPPERMANN



TWIN «C» TRACK CANTILEVER SYSTEM



15 + 15 BOLTS 15 + 15 RIVET NUTS INCLUDED



3 AXIS

2ND CANTILEVER LEAF ADJUSTABLE IN 3 AXES



C 2 HIGH QUALITY BEARINGS



32.000 cyclus

32.000 CYCLUS TESTED & PROVEN



CARRIAGES CENTER HOLES MILLED NOT LASERED



270 g/m²

HOT DIPPED GALVANIZED



MULTI RIVITED SECTIONS



+ 50°C TESTED & PROVEN



JAPANESE ROBOTICS FANUC



- 37°C TESTED AND PROVEN



UNIBERSITY OF TECHNOLOGY - BRNO



BUILD IN FLYING HOLE PUNCH EVERY 400 mm



MADE IN CZECH REPUBLIC

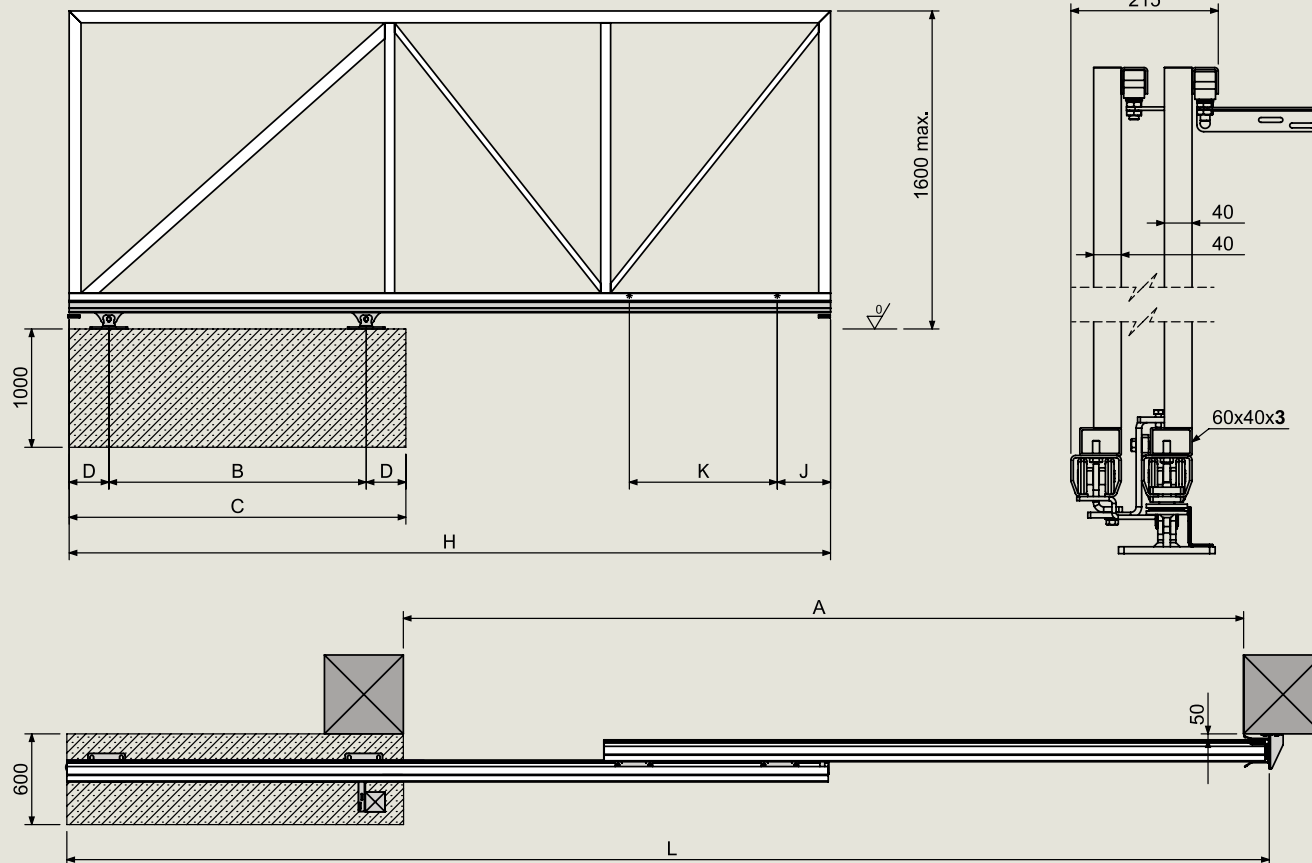





**NEW**

**CAIS** **TWIN DRIVE SET 5.0**

BI-FOLDING SWING GATE HARDWARE  
SPACE-SAVING FEATURE

**TWIN DRIVE 5.0**

BI-FOLDING DOUBLE LEAF  
SWING GATE HARDWARE  
SPACE-SAVING FEATURE  
MAX. 2,5 m SINGLE LEAF  
SINGLE LEAF MAX. 110 kg  
HINGES NOT INCLUDED

CODE: 1710901

**TWIN DRIVE 2.5**

BI-FOLDING SINGLE LEAF  
SWING GATE HARDWARE  
SPACE-SAVING FEATURE  
MAX. 2,5 m SINGLE LEAF  
SINGLE LEAF MAX. 110 kg  
HINGES NOT INCLUDED

CODE: 1710902



NO WELDING  
NEEDED



BOTTOM FIXED LEAF  
SAFETY FEATURE



SPACE SAVING  
FEATURE  
- 50% BACK SPACE



COMPACT  
PACKAGE



EASY  
ASSEMBLING



EASY  
TRANSPORT



FAST  
NO WELDING



FOR RESIDENTIAL  
USE ONLY



EASY TELESCOPIC  
ADJUSTMENT



TAKE  
AWAY



SUITABLE FOR  
ASYMMETRIC LEAFS  
100% + 50%



HIGH QUALITY  
GUARANTEED



SUITABLE FOR  
ALL STANDARD HINGES  
WITH SINGLE AXEL



CAIS  
INNOVATION

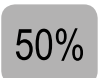

WIND RESISTANCE  
MAX. 50%  
LEAF CLOSURE



90° MAX. ANGLE



SUITABLE FOR  
ALL STANDARD  
SWING GATE  
OPERATORS



- 37°C  
TESTED & PROVEN



+ 50°C  
TESTED & PROVEN

L max.	A	B	C min. / max.	D min. / max.	E	F
2500	130	90	850 - 1250	300 - 1250	100	250

Valid for gate frame 60x40

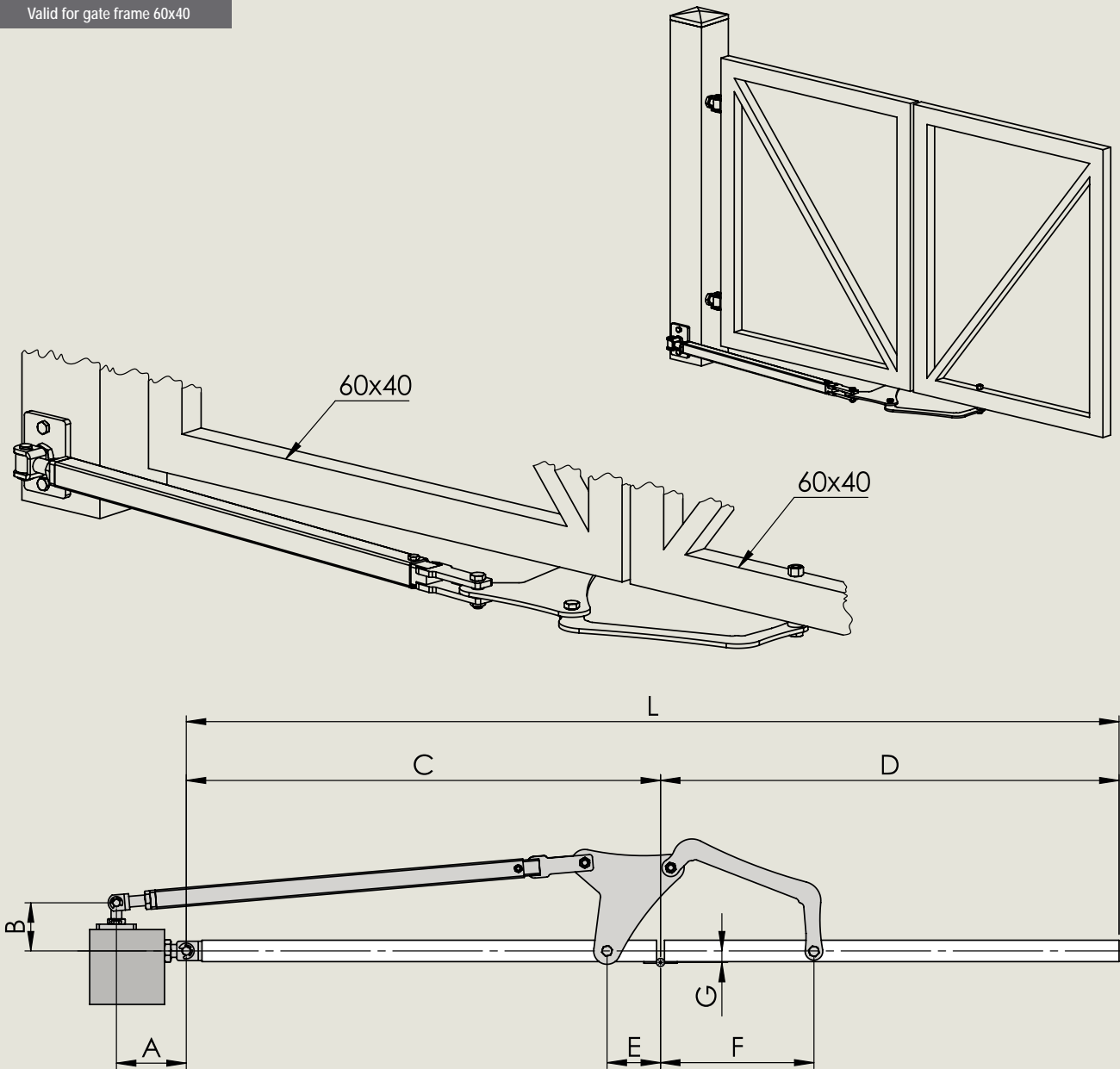



TAKE  
AWAY



CAIS  
INNOVATION

**NEW**

 **CHEVRON SET 2.5**

SWING GARAGE DOOR HARDWARE

CHEVRON 2.5		CODE: 1710903
L max.	H max.	MAX. CAPACITY DOOR
mm		kg
2500	2500	220



CAIS INNOVATION



TAKE AWAY



EASY TRANSPORT



SUITABLE FOR ALL STANDARD GARAGE DOOR OPENERS



EASY ASSEMBLING



FAST NO WELDING



FOR RESIDENTIAL USE ONLY



+ 50°C TESTED & PROVEN



- 37°C TESTED & PROVEN



HIGH QUALITY GUARANTEED



NO WELDING NEEDED

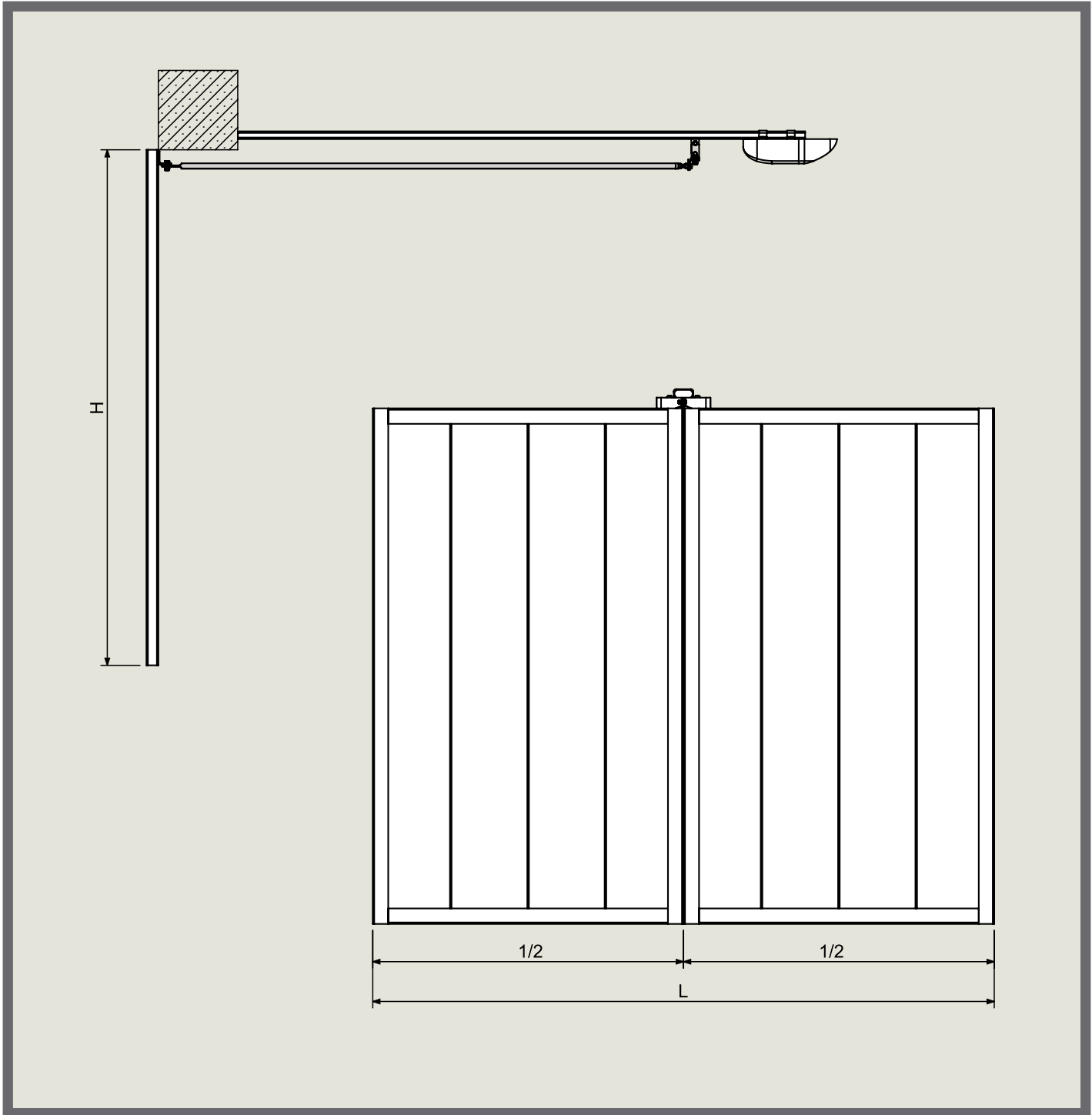



NEW 

 **HANGAR SET 6.6**

SLIDING DOOR HARDWARE

HANGAR 6.6	
SPEED C	4 pcs
STAGE SZ 6	2 pcs
STAGE SZ 1	1 pc
DF 190	2 pcs
DC 70	21 pcs
KHL 140	21 pcs
FINISH S	2 pcs
MCD 60/6	4 pcs
AD 150	4 pcs
MS 40	1 pc
KL 70	1 pc
TL 30	1 pc
TL 40	1 pc
TL 70	7 pcs
TL 90	1 pc
RS 40	4 pcs
CODE: 1710904	WEIGHT: 170 kg

HANGAR 4.4	
SPEED C	3 pcs
STAGE SZ 4	2 pcs
STAGE SZ 1	1 pc
DF 190	2 pcs
DC 70	15 pcs
KHL 140	15 pcs
FINISH S	2 pcs
MCD 60/4	4 pcs
AD 150	3 pcs
MS 40	1 pc
KL 70	1 pc
TL 30	1 pc
TL 40	1 pc
TL 70	6 pcs
TL 90	1 pc
RS 40	4 pcs
CODE: 1710905	WEIGHT: 126 kg

HANGAR 2.2	
SPEED C	2 pcs
STAGE SZ 2,8	2 pcs
DF 190	1 pc
DC 70	10 pcs
KHL 140	10 pcs
FINISH S	2 pcs
MCD 60/4	2 pcs
AD 150	2 pcs
MS 40	1 pc
KL 70	1 pc
TL 30	1 pc
TL 40	1 pc
TL 70	5 pcs
TL 90	1 pc
RS 40	4 pcs
CODE: 1710906	WEIGHT: 68 kg

BRUSH 6.6	
BD 25/2	3 pcs
BD 35/2	9 pcs
BD 45/2	3 pcs
AD 25/2	9 pcs
AS 25/2	3 pcs
AR 25/2	3 pcs
CODE: 1710907	WEIGHT: 9 kg

BRUSH 4.4	
BD 25/2	2 pcs
BD 35/2	6 pcs
BD 45/2	2 pcs
AD 25/2	6 pcs
AS 25/2	2 pcs
AR 25/2	2 pcs
CODE: 1710908	WEIGHT: 6,5 kg

BRUSH 2.2	
BD 25/2	1 pc
BD 35/2	3 pcs
BD 45/2	1 pc
AD 25/2	3 pcs
AS 25/2	1 pc
AR 25/2	1 pc
CODE: 1710909	WEIGHT: 3,5 kg

COMPONENTS & DIMENSIONS - HANGAR 6.6									6 m / 960 kg
CARRIAGE	GUIDE	SUPPORT	NUMBER SUPPORT	NUMBER GARIAGE	NUMBER SUPRORT	LENGHT WING	DISTANCE BETWEEN SUPPORT	MAX. CAPACITY WING TO 6000 mm	
			DC 70/KHL	SPEED C	AD 150	L	A		
SPEED C	STAGE SZ	DC 70/KHL	14	4	4	6000	500	1200	
SPEED C	STAGE SZ	DC 70/KHL	11	4	4	6000	650	960	

COMPONENTS & DIMENSIONS - HANGAR 4.4									4 m / 640 kg
CARRIAGE	GUIDE	SUPPORT	NUMBER SUPPORT	NUMBER GARIAGE	NUMBER SUPRORT	LENGHT WING	DISTANCE BETWEEN SUPPORT	MAX. CAPACITY WING TO 4000 mm	
			DC 70/KHL	SPEED C	AD 150	L	A		
SPEED C	STAGE SZ	DC 70/KHL	10	3	3	4000	500	800	
SPEED C	STAGE SZ	DC 70/KHL	8	3	3	4000	650	640	

COMPONENTS & DIMENSIONS - HANGAR 2.2									2 m / 320 kg
CARRIAGE	GUIDE	SUPPORT	NUMBER SUPPORT	NUMBER GARIAGE	NUMBER SUPRORT	LENGHT WING	DISTANCE BETWEEN SUPPORT	MAX. CAPACITY WING TO 2000 mm	
			DC 70/KHL	SPEED C	AD 150	L	A		
SPEED C	STAGE SZ	DC 70/KHL	5	2	2	2000	500	400	
SPEED C	STAGE SZ	DC 70/KHL	4	2	2	2000	650	320	



GERMAN STEEL WUPPERMANN



SUITABLE FOR INTERNAL AND EXTERNAL INSTALLATION



HOT DIPPED GALVANIZED



NO WELDING NEEDED



SLIM LEAF 46 mm



FOR INDUSTRIAL USE ONLY



EASY ASSEMBLING



FAST NO WELDING



LINEAR INSTALLATION WITHOUT LIMITS



HIGH QUALITY GUARANTEED



+ 50°C TESTED & PROVEN



CAIS INNOVATION



- 37°C TESTED & PROVEN

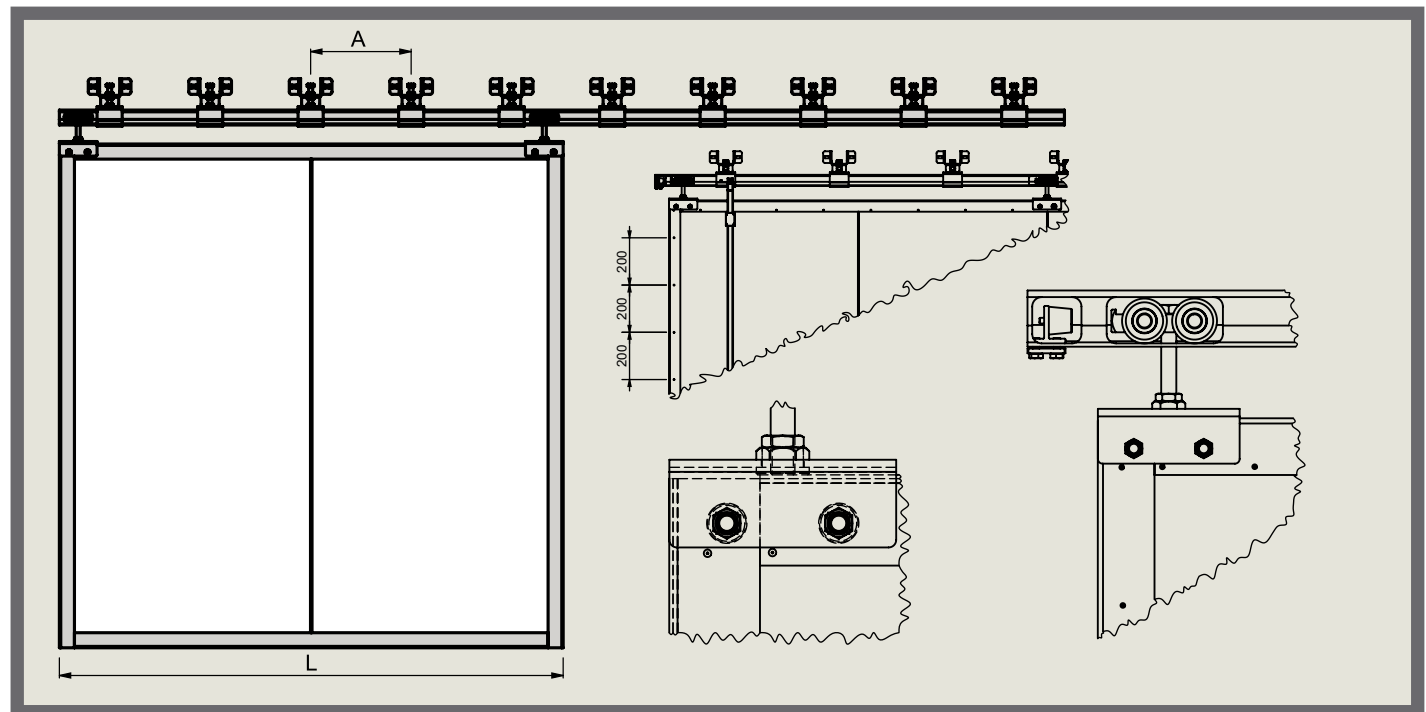

PATENT OFFICE  
PATENTED OFFICE PRIKRYL HAS  
REGISTERED AT INDUSTRIAL  
PROPERTY OFFICE THE UTILITY  
MODEL NUMBER 28617 FOR E-BOX  
CANTILEVER GATE. PRODUCED BY  
CAIS s.r.o.

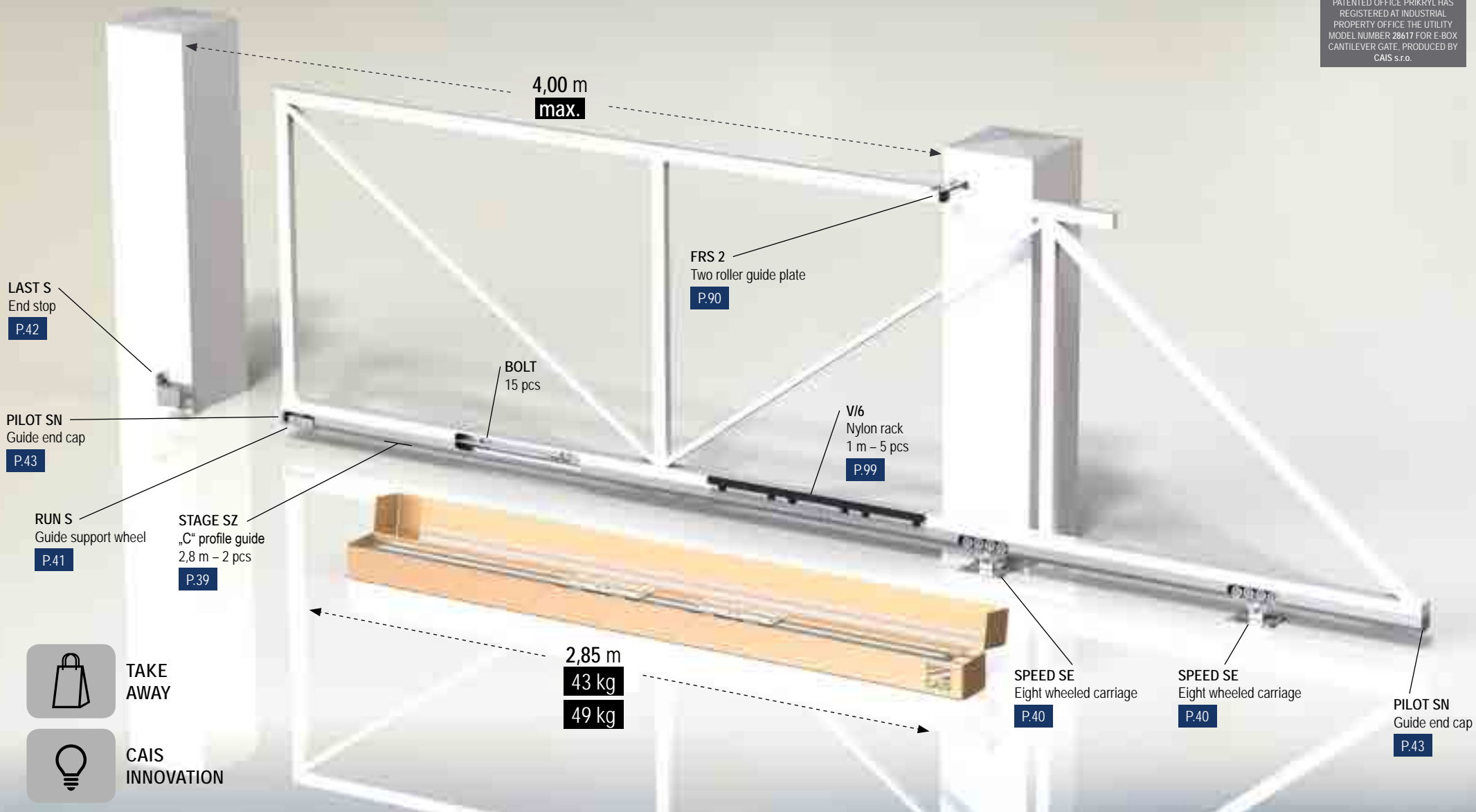

PATENT OFFICE 

 **ALL IN ONE SET 4.0**

CANTILEVER HARDWARE

E-BOX SE 02	E-BOX SE 03
SPEED SE ..... 2 pcs	SPEED SE ..... 2 pcs
STAGE SZ 2,8 m ..... 2 pcs	STAGE SZ 2,8 m ..... 2 pcs
RUN S ..... 1 pc	RUN S ..... 1 pc
LAST S ..... 1 pc	LAST S ..... 1 pc
PILOT SN ..... 2 pcs	PILOT SN ..... 2 pcs
FRS 2 ..... 1 pc	FRS 2 ..... 1 pc
BOLT M10x25 ..... 15 pcs	BOLT M10x25 ..... 15 pcs
RIVET NUT ..... 15 pcs	RIVET NUT ..... 15 pcs
	V/6 ..... 5 pcs
<b>Total weight = 43 kg</b>	<b>Total weight = 49 kg</b>
CODE: 1710053	CODE: 1710054

E-BOX SE	mm; kg	mm; kg	mm; kg	mm; kg	mm; kg	mm; kg
A	3000	3200	3400	3600	3800	4000
max. weight gate	325 kg	325 kg	325 kg	325 kg	325 kg	325 kg
B	900	960	1020	1080	1140	1200
C	1300	1360	1420	1480	1540	1600
D	270	270	270	270	270	270
F	130	130	130	130	130	130

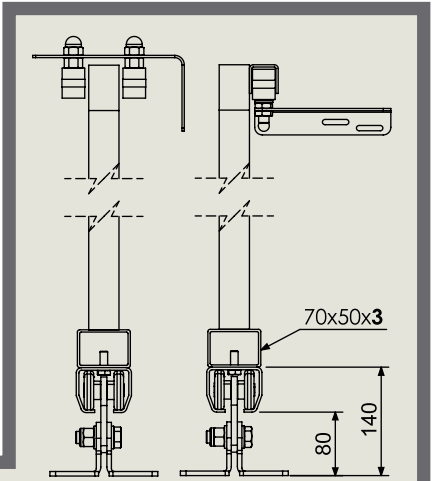

NO WELDING NEEDED



TAKE AWAY



EASY ASSEMBLING



C 2 HQ BEARINGS



FAST NO WELDING



CARRIAGES CENTER HOLES MILLED NOT LASERED



15 BOLTS 15 RIVET NUTS INCLUDED



MULTI RIVETED SECTIONS



«C» TRACK SERIAL NO. 100% COMPATIBILITY CARRIAGE TESTED



COMPACT PACKAGING 2850 x 170 x 140 mm 42 kg - 49 kg



GERMAN STEEL WUPPERMANN



JAPANESE ROBOTICS FANUC



HOT DIPPED GALVANIZED



UNIVERSITY OF TECHNOLOGY - BRNO



ARROW STRAIGHT «C» TRACK



- 37°C TESTED & PROVEN



BUILD IN FLYING HOLE PUNCH - EVERY 400 mm



+ 50°C TESTED & PROVEN



GALVANIZED INTERNAL EDGES



MADE IN CZECH REPUBLIC

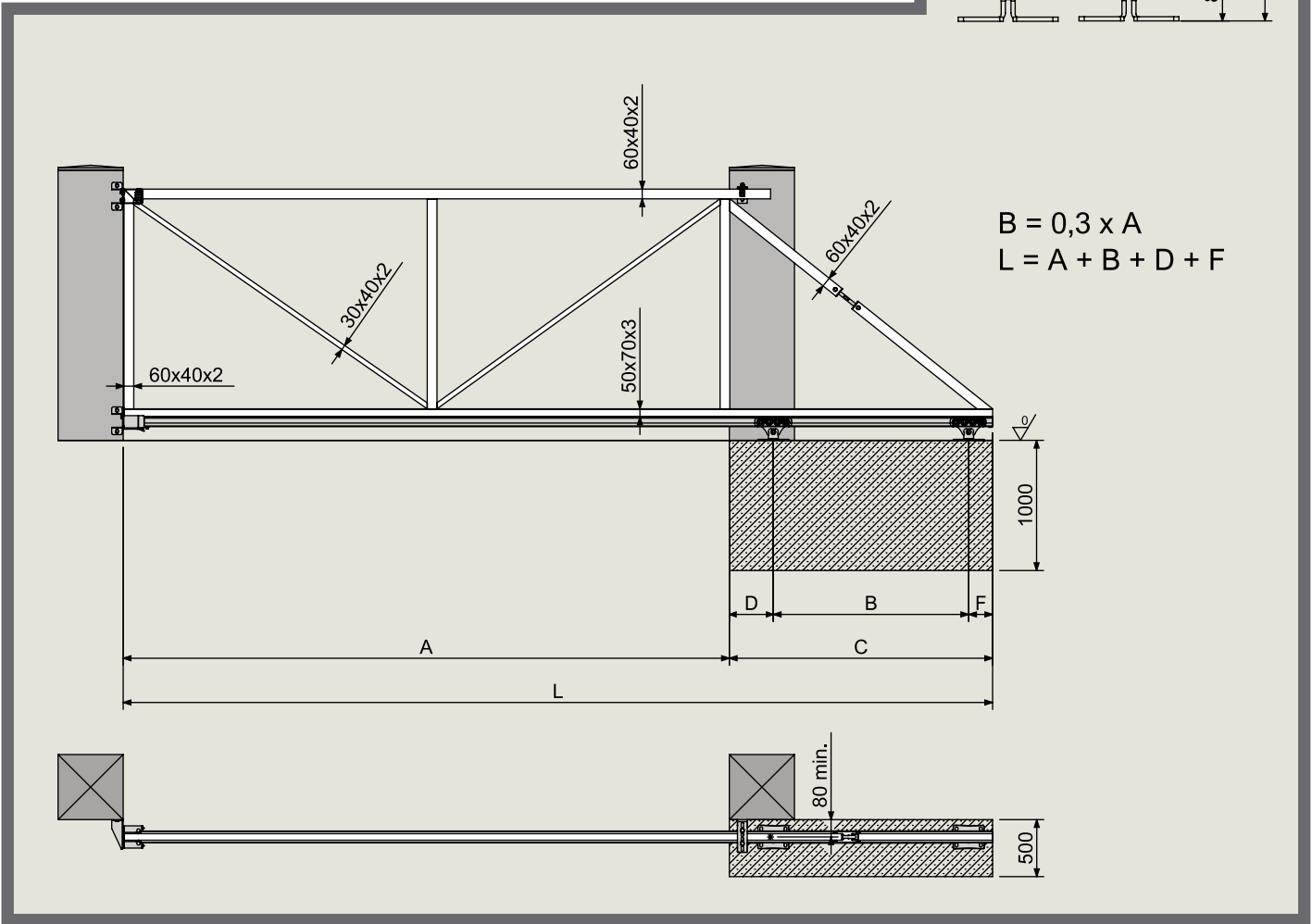



## SOLE SE 02

SET

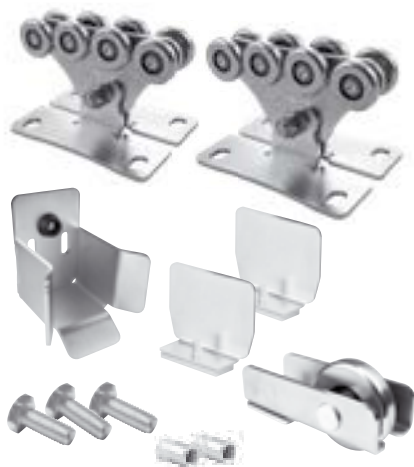

SPEED SE ..... 2 pcs  
 RUN S ..... 1 pc  
 LAST S ..... 1 pc  
 PILOT SN ..... 2 pcs  
 BOLT M10x25 ..... 15 pcs  
 RIVET NUT ..... 15 pcs

ART. SET / kg  
 SOLE SE 02 ..... 11,5 kg

GATES UP TO  
 WEIGHT ..... 325 kg

CODE: 1710018

## MARE S 02

SET

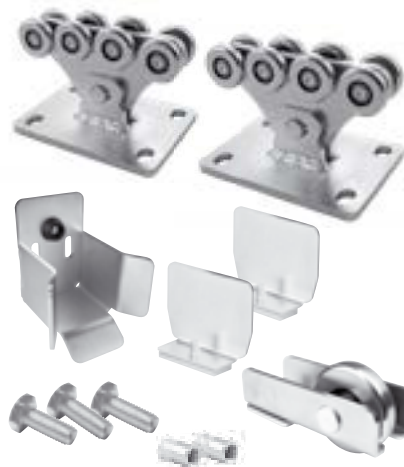

SPEED S ..... 2 pcs  
 RUN S ..... 1 pc  
 LAST S ..... 1 pc  
 PILOT SN ..... 2 pcs  
 BOLT M10x25 ..... 15 pcs  
 RIVET NUT ..... 15 pcs

ART. SET / kg  
 MARE S 02 ..... 13,9 kg

GATES UP TO  
 WEIGHT ..... 450 kg

CODE: 1710040

## VITA ME 02

SET

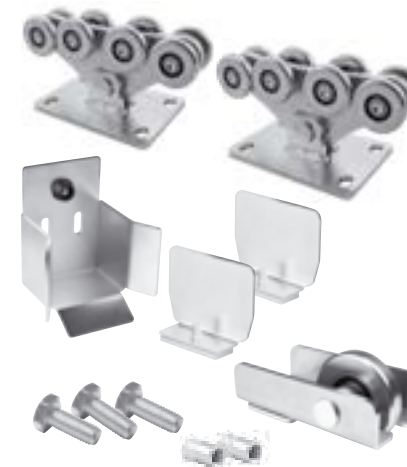

SPEED ME ..... 2 pcs  
 RUN M ..... 1 pc  
 LAST M ..... 1 pc  
 PILOT MN ..... 2 pcs  
 BOLT M10x25 ..... 15 pcs  
 RIVET NUT ..... 15 pcs

ART. SET / kg  
 VITA ME 02 ..... 22,4 kg

GATES UP TO  
 WEIGHT ..... 700 kg

CODE: 1710042

## SOLE SE 03

SET



SPEED SE ..... 2 pcs  
 RUN S ..... 1 pc  
 LAST S ..... 1 pc  
 PILOT SN ..... 2 pcs  
 FRS 2 ..... 1 pc  
 BOLT M10x25 ..... 15 pcs  
 RIVET NUT ..... 15 pcs

ART. SET / kg  
 SOLE SE 03 ..... 12,1 kg

GATES UP TO  
 WEIGHT ..... 325 kg

CODE: 1710019

## MARE S 03

SET



SPEED S ..... 2 pcs  
 RUN S ..... 1 pc  
 LAST S ..... 1 pc  
 PILOT SN ..... 2 pcs  
 FRS 2 ..... 1 pc  
 BOLT M10x25 ..... 15 pcs  
 RIVET NUT ..... 15 pcs

ART. SET / kg  
 MARE S 03 ..... 14,5 kg

GATES UP TO  
 WEIGHT ..... 450 kg

CODE: 1710041

## VITA ME 03

SET



SPEED ME ..... 2 pcs  
 RUN M ..... 1 pc  
 LAST M ..... 1 pc  
 PILOT MN ..... 2 pcs  
 FRM 2 ..... 1 pc  
 BOLT M10x25 ..... 15 pcs  
 RIVET NUT ..... 15 pcs

ART. SET / kg  
 VITA ME 03 ..... 23,7 kg

GATES UP TO  
 WEIGHT ..... 700 kg

CODE: 1710043

**FERO SBE 02**

**SET**



- SPEED SE ..... 2 pcs
- STAGE SB 5,6 ..... 1 pc
- RUN S ..... 1 pc
- LAST S ..... 1 pc
- PILOT SN ..... 2 pcs
- BOLT M10x25 ..... 15 pcs
- RIVET NUT ..... 15 pcs

ART. SET / kg  
 FERO SBE 02 ..... 42,3 kg

GATES UP TO  
 WEIGHT ..... 325 kg  
 LENGHT ..... 4 m

CODE: 1710014

**FERO SZE 02**

**SET**



- SPEED SE ..... 2 pcs
- STAGE SZ 5,6 ..... 1 pc
- RUN S ..... 1 pc
- LAST S ..... 1 pc
- PILOT SN ..... 2 pcs
- BOLT M10x25 ..... 15 pcs
- RIVET NUT ..... 15 pcs

ART. SET / kg  
 FERO SZE 02 ..... 42,3 kg

GATES UP TO  
 WEIGHT ..... 325 kg  
 LENGHT ..... 4 m

CODE: 1710007

**DINO SBE 02**

**SET**



- SPEED SE ..... 2 pcs
- STAGE SB 6 ..... 1 pc
- RUN S ..... 1 pc
- LAST S ..... 1 pc
- PILOT SN ..... 2 pcs
- BOLT M10x25 ..... 15 pcs
- RIVET NUT ..... 15 pcs

ART. SET / kg  
 DINO SBE 02 ..... 44,5 kg

GATES UP TO  
 WEIGHT ..... 325 kg  
 LENGHT ..... 4,5 m

CODE: 1710047

**FERO SBE 03**

**SET**



- SPEED SE ..... 2 pcs
- STAGE SB 5,6 ..... 1 pc
- RUN S ..... 1 pc
- LAST S ..... 1 pc
- PILOT SN ..... 2 pcs
- FRS 2 ..... 1 pc
- BOLT M10x25 ..... 15 pcs
- RIVET NUT ..... 15 pcs

ART. SET / kg  
 FERO SBE 03 ..... 42,9 kg

GATES UP TO  
 WEIGHT ..... 325 kg  
 LENGHT ..... 4 m

CODE: 1710044

**FERO SZE 03**

**SET**



- SPEED SE ..... 2 pcs
- STAGE SZ 5,6 ..... 1 pc
- RUN S ..... 1 pc
- LAST S ..... 1 pc
- PILOT SN ..... 2 pcs
- FRS 2 ..... 1 pc
- BOLT M10x25 ..... 15 pcs
- RIVET NUT ..... 15 pcs

ART. SET / kg  
 FERO SZE 03 ..... 42,9 kg

GATES UP TO  
 WEIGHT ..... 325 kg  
 LENGHT ..... 4 m

CODE: 1710045

**DINO SBE 03**

**SET**



- SPEED SE ..... 2 pcs
- STAGE SB 6 ..... 1 pc
- RUN S ..... 1 pc
- LAST S ..... 1 pc
- PILOT SN ..... 2 pcs
- FRS 2 ..... 1 pc
- BOLT M10x25 ..... 15 pcs
- RIVET NUT ..... 15 pcs

ART. SET / kg  
 DINO SBE 03 ..... 45,1 kg

GATES UP TO  
 WEIGHT ..... 325 kg  
 LENGHT ..... 4,5 m

CODE: 1710048

**DINO SZE 02**

**SET**

- SPEED SE ..... 2 pcs
- STAGE SZ 6 ..... 1 pc
- RUN S ..... 1 pc
- LAST S ..... 1 pc
- PILOT SN ..... 2 pcs
- BOLT M10x25 ..... 15 pcs
- RIVET NUT ..... 15 pcs

ART. SET / kg  
DINO SZE 02 ..... 44,5 kg

GATES UP TO  
WEIGHT ..... 325 kg  
LENGHT ..... 4,5 m

CODE: 1710049



**ENZO SB 02**

**SET**

- SPEED S ..... 2 pcs
- STAGE SB 6 ..... 1 pc
- RUN S ..... 1 pc
- LAST S ..... 1 pc
- PILOT SN ..... 2 pcs
- BOLT M10x25 ..... 15 pcs
- RIVET NUT ..... 15 pcs

ART. SET / kg  
ENZO SB 02 ..... 46,9 kg

GATES UP TO  
WEIGHT ..... 450 kg  
LENGHT ..... 4,5 m

CODE: 1710012



**ENZO SZ 02**

**SET**

- SPEED S ..... 2 pcs
- STAGE SZ 6 ..... 1 pc
- RUN S ..... 1 pc
- LAST S ..... 1 pc
- PILOT SN ..... 2 pcs
- BOLT M10x25 ..... 15 pcs
- RIVET NUT ..... 15 pcs

ART. SET / kg  
ENZO SZ 02 ..... 46,9 kg

GATES UP TO  
WEIGHT ..... 450 kg  
LENGHT ..... 4,5 m

CODE: 1710005



**DINO SZE 03**

**SET**

- SPEED SE ..... 2 pcs
- STAGE SZ 6 ..... 1 pc
- RUN S ..... 1 pc
- LAST S ..... 1 pc
- PILOT SN ..... 2 pcs
- FRS 2 ..... 1 pc
- BOLT M10x25 ..... 15 pcs
- RIVET NUT ..... 15 pcs

ART. SET / kg  
DINO SZE 03 ..... 45,1 kg

GATES UP TO  
WEIGHT ..... 325 kg  
LENGHT ..... 4,5 m

CODE: 1710050



**ENZO SB 03**

**SET**

- SPEED S ..... 2 pcs
- STAGE SB 6 ..... 1 pc
- RUN S ..... 1 pc
- LAST S ..... 1 pc
- PILOT SN ..... 2 pcs
- FRS 2 ..... 1 pc
- BOLT M10x25 ..... 15 pcs
- RIVET NUT ..... 15 pcs

ART. SET / kg  
ENZO SB 03 ..... 47,5 kg

GATES UP TO  
WEIGHT ..... 450 kg  
LENGHT ..... 4,5 m

CODE: 1710051

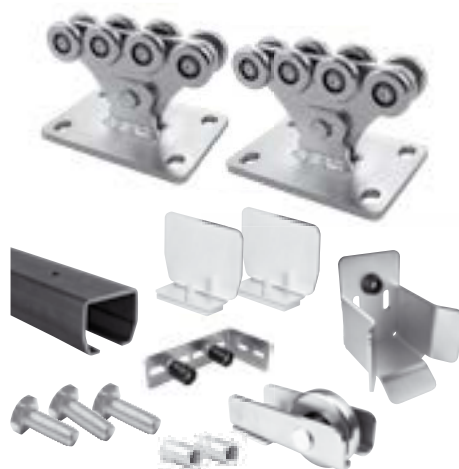

**ENZO SZ 03**

**SET**

- SPEED S ..... 2 pcs
- STAGE SZ 6 ..... 1 pc
- RUN S ..... 1 pc
- LAST S ..... 1 pc
- PILOT SN ..... 2 pcs
- FRS 2 ..... 1 pc
- BOLT M10x25 ..... 15 pcs
- RIVET NUT ..... 15 pcs

ART. SET / kg  
ENZO SZ 03 ..... 47,5 kg

GATES UP TO  
WEIGHT ..... 450 kg  
LENGHT ..... 4,5 m

CODE: 1710046



DEMO MBE 02

SET



- SPEED ME ..... 2 pcs
- STAGE MB 6 ..... 1 pc
- RUN M ..... 1 pc
- LAST M ..... 1 pc
- PILOT MN ..... 2 pcs
- BOLT M10x25 ..... 15 pcs
- RIVET NUT ..... 15 pcs

ART. SET / kg  
DEMO MBE 02 ..... 87,8 kg

GATES UP TO  
WEIGHT ..... 500 kg  
LENGHT ..... 4 m

CODE: 1710016

DEMO MZE 02

SET



- SPEED ME ..... 2 pcs
- STAGE MZ 6 ..... 1 pc
- RUN M ..... 1 pc
- LAST M ..... 1 pc
- PILOT MN ..... 2 pcs
- BOLT M10x25 ..... 15 pcs
- RIVET NUT ..... 15 pcs

ART. SET / kg  
DEMO MZE 02 ..... 87,8 kg

GATES UP TO  
WEIGHT ..... 500 kg  
LENGHT ..... 4 m

CODE: 1710010

DEMO MBE 23

SET



- SPEED ME ..... 2 pcs
- STAGE MB 6 ..... 1 pc
- STAGE MB 3 ..... 1 pc
- RUN M ..... 1 pc
- LAST M ..... 1 pc
- PILOT MN ..... 2 pcs
- FRM 2 ..... 1 pc
- BOLT M10x25 ..... 30 pcs
- RIVET NUT ..... 30 pcs

ART. SET / kg  
DEMO MBE 23 ..... 122,3 kg

GATES UP TO  
WEIGHT ..... 600 kg  
LENGHT ..... 6 m

CODE: 1710072

DEMO MBE 03

SET



- SPEED ME ..... 2 pcs
- STAGE MB 6 ..... 1 pc
- RUN M ..... 1 pc
- LAST M ..... 1 pc
- PILOT MN ..... 2 pcs
- FRM 2 ..... 1 pc
- BOLT M10x25 ..... 15 pcs
- RIVET NUT ..... 15 pcs

ART. SET / kg  
DEMO MBE 03 ..... 89,1 kg

GATES UP TO  
WEIGHT ..... 500 kg  
LENGHT ..... 4 m

CODE: 1710052

DEMO MZE 03

SET



- SPEED ME ..... 2 pcs
- STAGE MZ 6 ..... 1 pc
- RUN M ..... 1 pc
- LAST M ..... 1 pc
- PILOT MN ..... 2 pcs
- FRM 2 ..... 1 pc
- BOLT M10x25 ..... 15 pcs
- RIVET NUT ..... 15 pcs

ART. SET / kg  
DEMO MZE 03 ..... 89,1 kg

GATES UP TO  
WEIGHT ..... 500 kg  
LENGHT ..... 4 m

CODE: 1710038

DEMO MZE 23

SET



- SPEED ME ..... 2 pcs
- STAGE MZ 6 ..... 1 pc
- STAGE MZ 3 ..... 1 pc
- RUN M ..... 1 pc
- LAST M ..... 1 pc
- PILOT MN ..... 2 pcs
- FRM 2 ..... 1 pc
- BOLT M10x25 ..... 30 pcs
- RIVET NUT ..... 30 pcs

ART. SET / kg  
DEMO MZE 23 ..... 122,3 kg

GATES UP TO  
WEIGHT ..... 600 kg  
LENGHT ..... 6 m

CODE: 1710073

“THE BEST WAY  
TO PREDICT THE FUTURE  
IS TO CREATE IT”

– Abraham Lincoln



RESEARCH & DEVELOPMENT  
CAIS PARTNER

"ALWAYS DELIVER  
MORE THAN  
EXPECTED"

– Larry Page



HIGH QUALITY GERMAN STEEL  
CAIS PARTNER









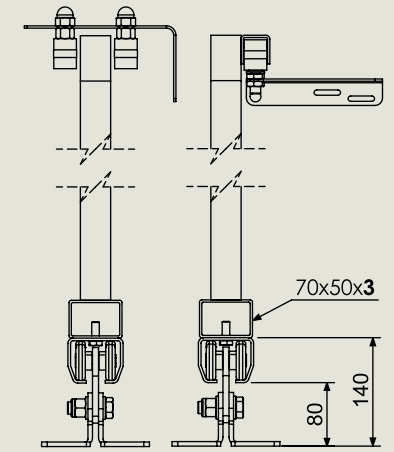











**CAIS** CANTILEVER SE 4.0

CANTILEVER HARDWARE

CANTILEVER SE						
	mm; kg	mm; kg	mm; kg	mm; kg	mm; kg	mm; kg
A	3000	3200	3400	3600	3800	4000
max. weight gate	325 kg	325 kg	325 kg	325 kg	325 kg	325 kg
B	900	960	1020	1080	1140	1200
C	1300	1360	1420	1480	1540	1600
D	270	270	270	270	270	270
F	130	130	130	130	130	130



-  EASY ASSEMBLING
-  FAST NO WELDING
-  15 BOLTS  
15 RIVET NUTS INCLUDED (\*)
-  «C» TRACK SERIAL NO. 100% COMPATIBILITY CARRIAGE TESTED
-  GERMAN STEEL WUPPERMANN
-  270 g/m<sup>2</sup> HOT DIPPED GALVANIZED
-  ARROW STRAIGHT «C» TRACK
-  BUILD IN FLYING HOLE PUNCH - EVERY 400 mm
-  GALVANIZED INTERNAL EDGES
-  MADE IN CZECH REPUBLIC
-  C 2 HQ BEARINGS
-  CARRIAGES CENTER HOLES MILLED NOT LASERED
-  MULTI RIVITED SECTIONS
-  JAPANESE ROBOTICS FANUC
-  UNIVERSITY OF TECHNOLOGY - BRNO
-  - 37°C TESTED & PROVEN
-  + 50°C TESTED & PROVEN
-  NO WELDING NEEDED

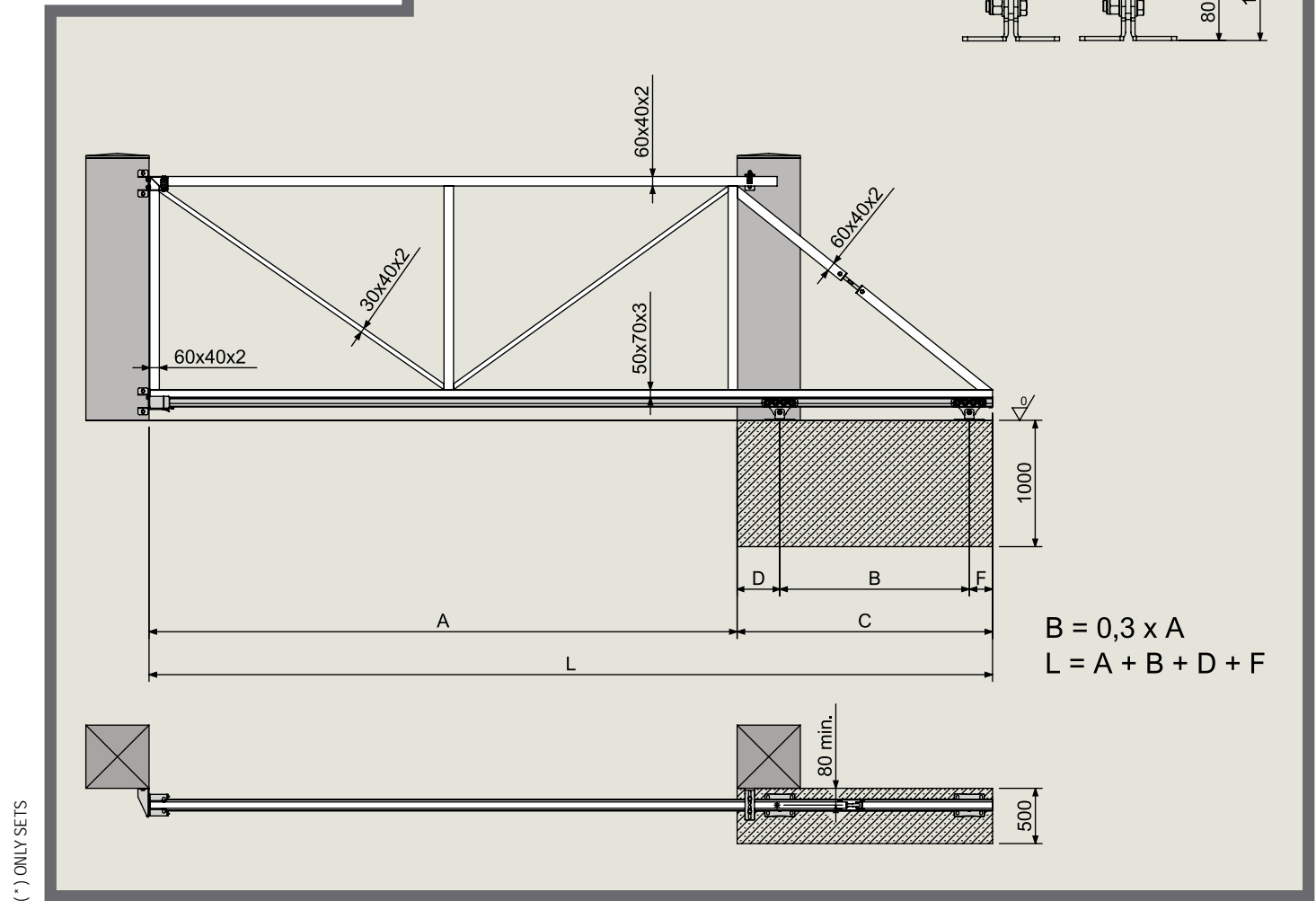











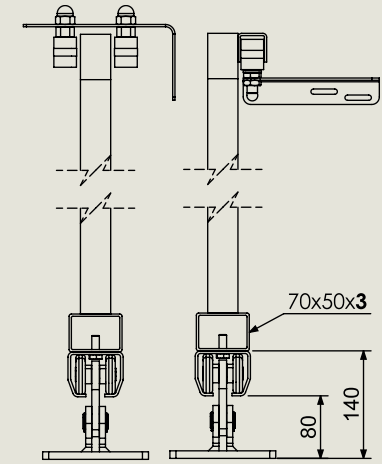











**CAIS** CANTILEVER S 4.5

CANTILEVER HARDWARE

CANTILEVER S								
	mm; kg	mm; kg	mm; kg	mm; kg	mm; kg	mm; kg	mm; kg	mm; kg
A	3000	3200	3400	3600	3800	4000	4200	4500
max. weight gate	325 kg	325 kg	325 kg	350 kg	375 kg	400 kg	425 kg	450 kg
B	900	960	1020	1080	1140	1200	1260	1350
C	1440	1500	1560	1620	1680	1740	1800	1890
D	270	270	270	270	270	270	270	270



-  EASY ASSEMBLING
-  FAST NO WELDING
-  15 BOLTS  
15 RIVET NUTS INCLUDED (\*)
-  «C» TRACK SERIAL NO.  
100% COMPATIBILITY  
CARRIAGE TESTED
-  GERMAN STEEL  
WUPPERMANN
-  270  
g/m<sup>2</sup> HOT DIPPED GALVANIZED
-  ARROW STRAIGHT  
«C» TRACK
-  BUILD IN FLYING HOLE  
PUNCH - EVERY 400 mm
-  GALVANIZED  
INTERNAL EDGES
-  MADE IN  
CZECH REPUBLIC
-  C 2  
HQ BEARINGS
-  CARRIAGES CENTER  
HOLES MILLED  
NOT LASERED
-  MULTI RIVETED  
SECTIONS
-  JAPANESE ROBOTICS  
FANUC
-  UNIVERSITY OF  
TECHNOLOGY - BRNO
-  - 37°C  
TESTED & PROVEN
-  + 50°C  
TESTED & PROVEN
-  NO WELDING  
NEEDED

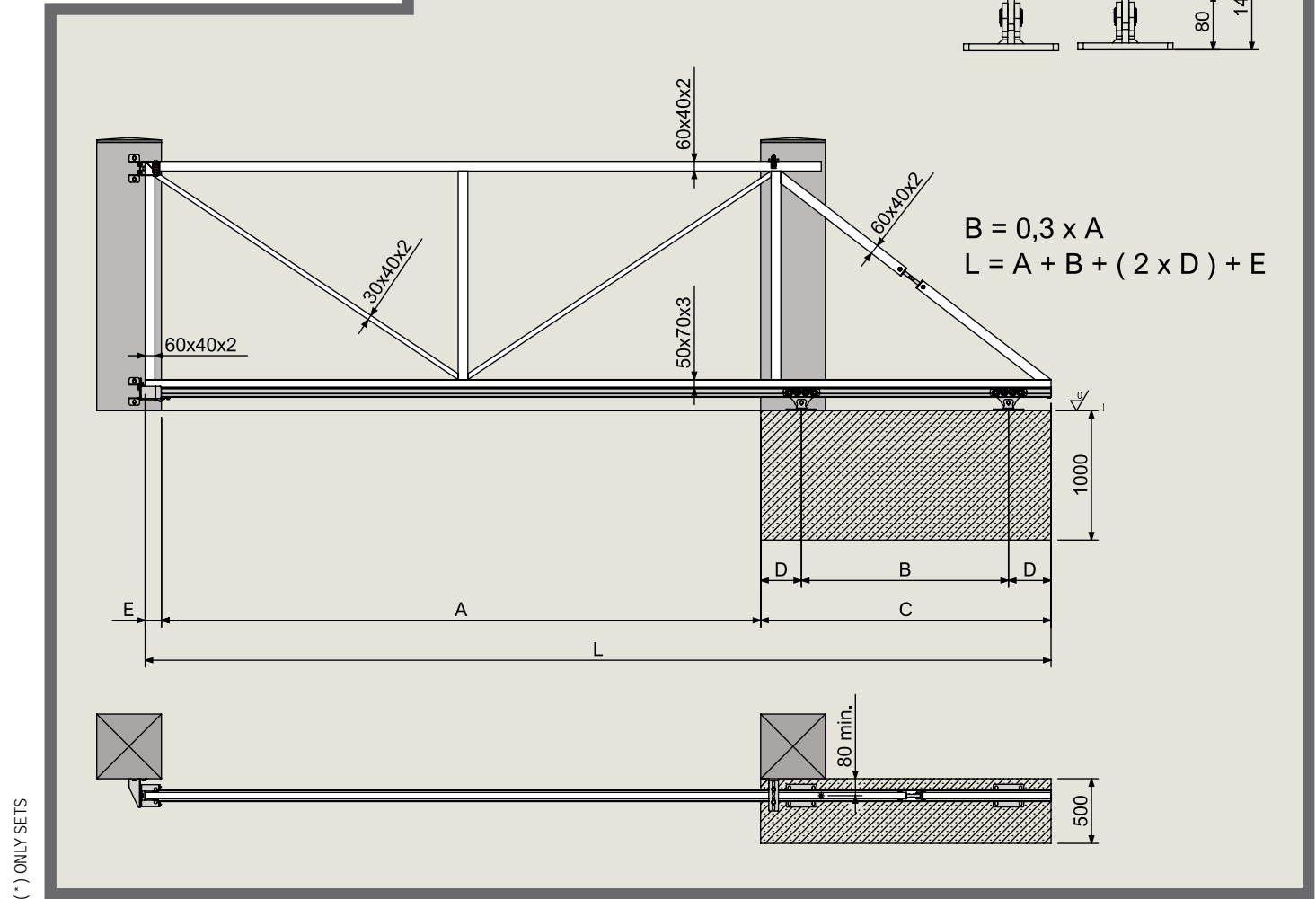

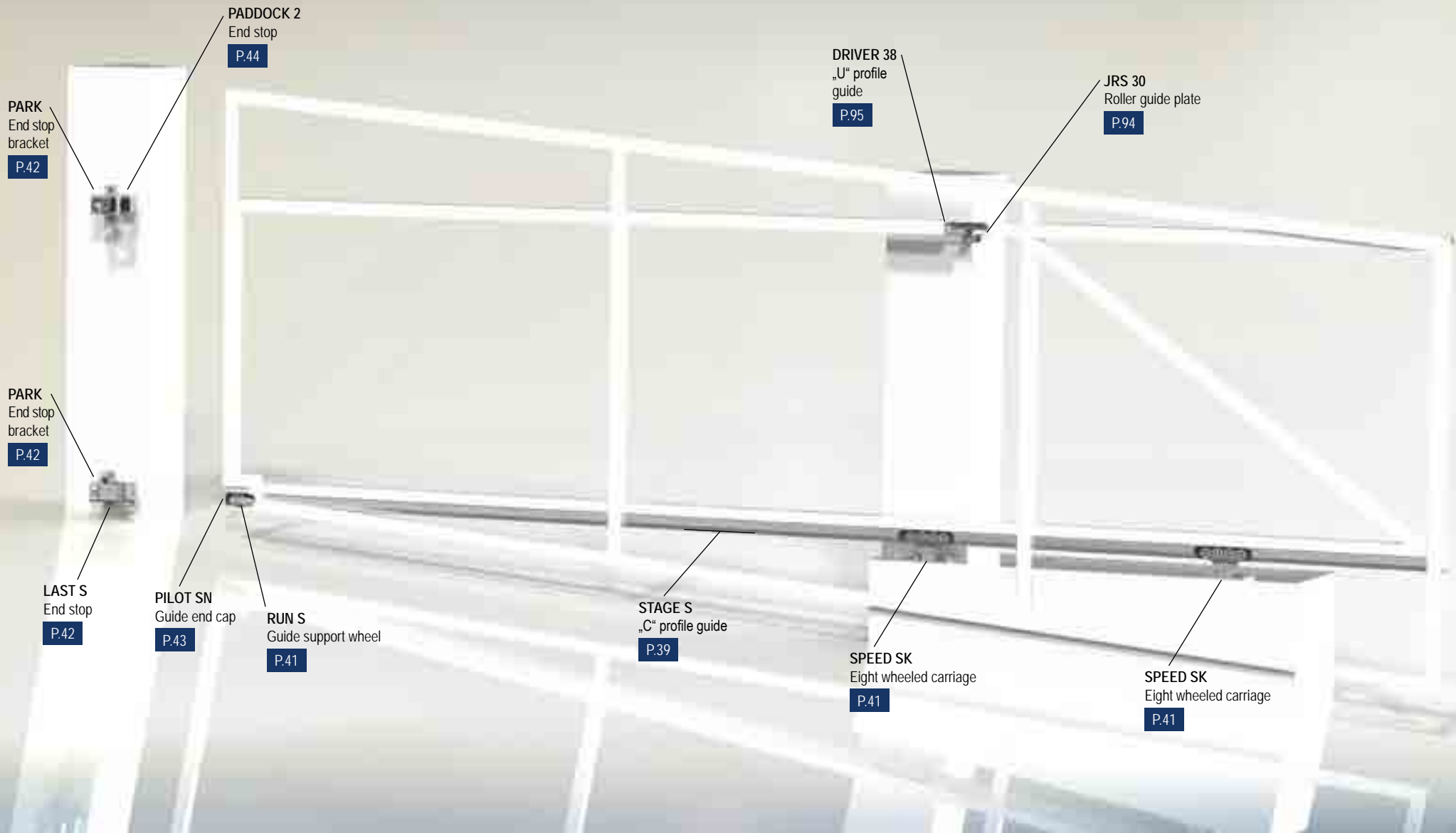

# CANTILEVER SK 4.5

CANTILEVER HARDWARE

CANTILEVER SK								
	mm: kg	mm: kg	mm: kg	mm: kg	mm: kg	mm: kg	mm: kg	mm: kg
A	3000	3200	3400	3600	3800	4000	4200	4500
max. weight gate	325 kg	325 kg	325 kg	350 kg	375 kg	400 kg	425 kg	450 kg
B	900	960	1020	1080	1140	1200	1260	1350
C	1440	1500	1560	1620	1680	1740	1800	1890
D	270	270	270	270	270	270	270	270

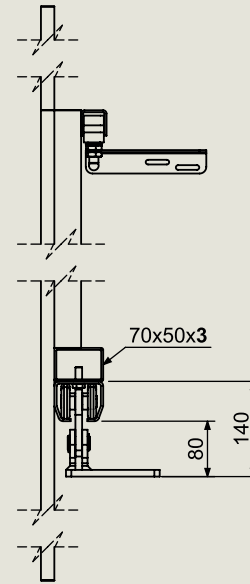

$$B = 0,3 \times A$$

$$L = A + B + (2 \times D) + E$$



SUITABLE FOR INCLINED SURFACE INSTALLATION



ASYMMETRIC EIGHT WHEELED CARRIAGE



EASY ASSEMBLING



C 2 HQ BEARINGS



FAST NO WELDING



CARRIAGES CENTER HOLES MILLED NOT LASERED



15 BOLTS  
15 RIVET NUTS INCLUDED (\*)



MULTI RIVETED SECTIONS



«C» TRACK SERIAL NO. 100% COMPATIBILITY CARRIAGE TESTED



JPN JAPANESE ROBOTICS FANUC



D GERMAN STEEL WUPPERMANN



R&D UNIVERSITY OF TECHNOLOGY - BRNO



270 g/m<sup>2</sup> HOT DIPPED GALVANIZED



-37°C TESTED & PROVEN



ARROW STRAIGHT «C» TRACK



+50°C TESTED & PROVEN



BUILD IN FLYING HOLE PUNCH - EVERY 400 mm



CZ MADE IN CZECH REPUBLIC



GALVANIZED INTERNAL EDGES



NO WELDING NEEDED

(\*) ONLY SETS

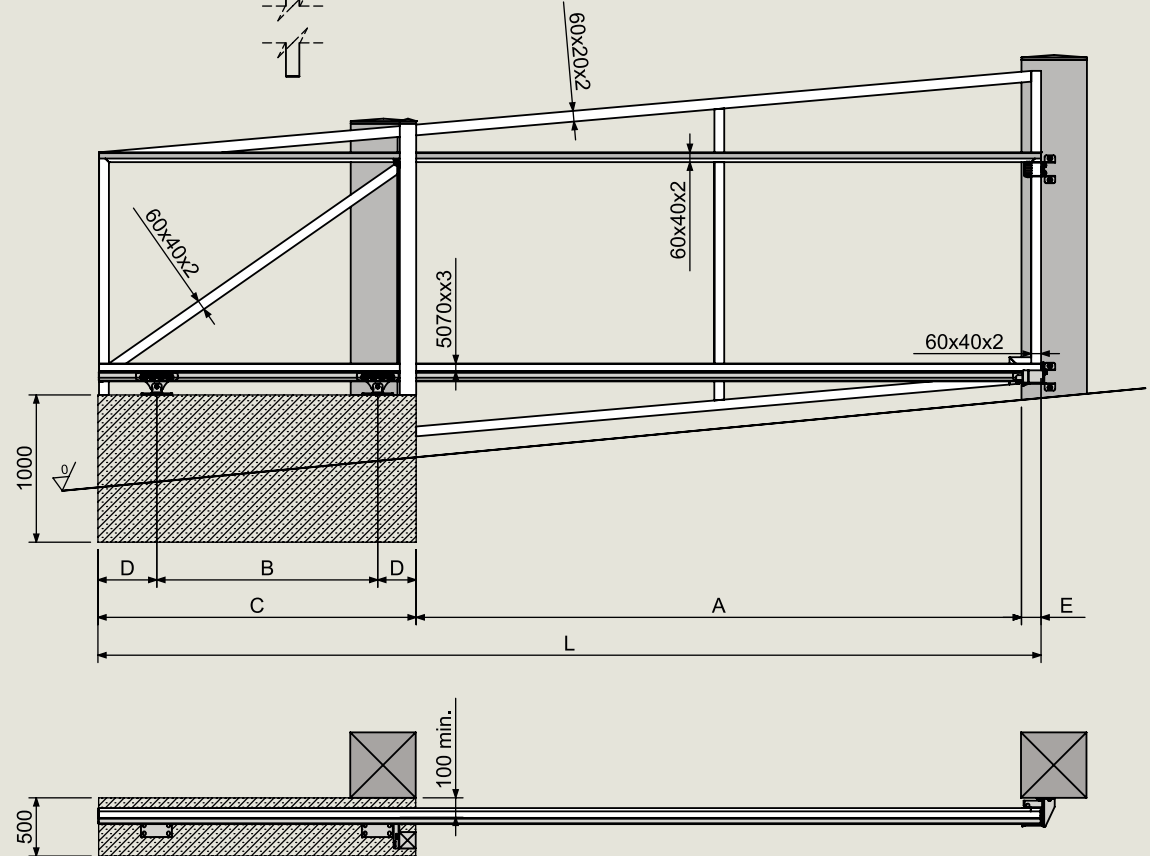



**W Wuppermann**

GERMAN STEEL

270  
g/m<sup>2</sup>

HOT  
DIPPED  
GALVANIZED



GALVANIZED  
INTERNAL  
EDGES



SPECIAL  
THICKNESS **3,50**  
mm

24  
months

24 MONTHS  
TESTED  
& PROVEN



- 37°C  
TESTED  
& PROVEN



+ 50°C  
TESTED  
& PROVEN

MADE IN  
CZECH  
REPUBLIC

BUILD IN  
FLYING HOLE PUNCH  
EVERY 400 mm



15 BOLTS  
15 RIVET NUTS  
INCLUDED (\*)



SERIAL NUMBER  
CARRIAGE COMPATIBILITY  
TESTED & PROVEN



EASY  
ASSEMBLING



FAST  
NO WELDING



**T** BRNO  
UNIVERSITY  
OF TECHNOLOGY



ARROW  
STRAIGHT  
«C» TRACK

EIGHTEEN ROLL FORMERS  
THE MOST IN THE INDUSTRY  
REMOVE THE INSET «MEMORY» OF STEEL **18**

AVAILABLE  
CUSTOMISED LENGTHS  
UNDER SPECIAL TERMS

SLOW ROLLING  
NO HEAT DURING THE PRODUCTION  
KEEPING THE MATERIAL WHERE IT IS ROLLED

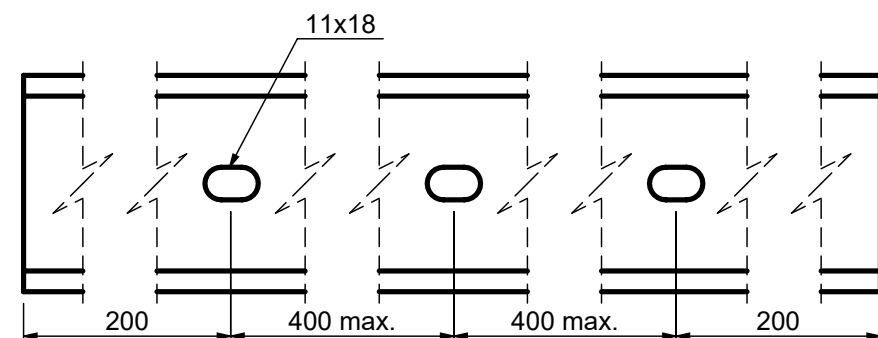
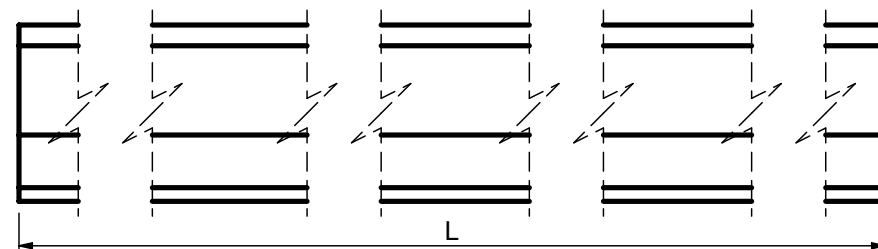
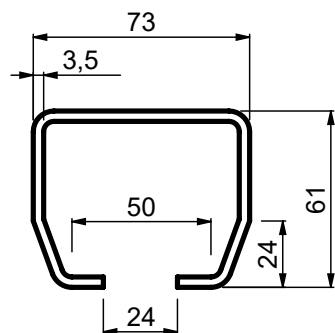
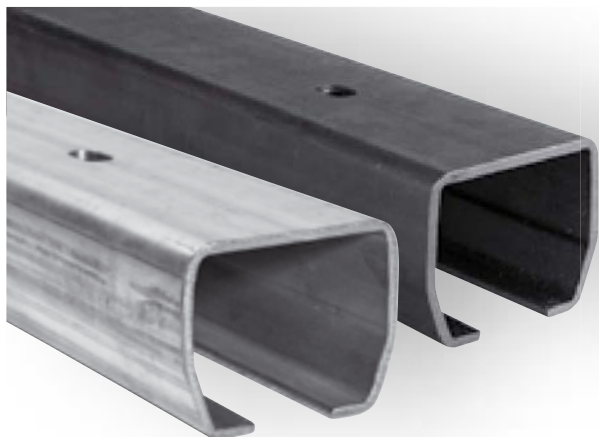

- (GB) „C“ PROFIL GUIDE FOR CANTILEVER GATE
- (D) „C“ PROFIL FÜR FREITRAGENDE SCHIEBETÖRE
- (F) GUIDE À PROFIL EN « C » POUR PORTAIL AUTOPORTANT
- (E) GUÍA CON PERFIL "C" PARA PUERTA VOLADIZA
- (P) GUIA DE PERFIL "C" PARA PORTÃO CANTILEVER
- (I) GUIDA CON PROFILO A "C" PER CANCELLO AUTOPORTANTE
- (DK) "C" PROFILVANGE TIL FRITBÆRENDE PORT
- (NL) "C" PROFIEL GELEIDER VOOR VRIJDRAGENDE SCHUIFPOORT
- (N) "C"-PROFILSKINNE FOR FRITTBÆRENDE PORTX
- (S) "C" GEJDPROFIL FÖR FRIBÄRANDE GRIND
- (FIN) "C" -PROFILLIÖHJAIN ULÖKEKANNETEISEEN PORTTIIN
- (PL) SZYNA DO BRAM SAMONOŚNYCH
- (SK) NOSNÝ „C“ PROFIL PRE POSUVNÚ SAMONOSNÚ BRÁNU
- (EE) "C" -PROFILLI JUHIK KONSOLVÄRAVA JAOKS
- (LT) „C“ FORMOS PROFILIUOTAS KREIPTUVAS GEMBINIAMS VARTAMS
- (LV) "C" VEIDA PROFILS KONSOLVEIDA VĀRTIEM

- (CZ) ŠÍNA „C“ PROFIL PRO POSUVNOU SAMONOSNOU BRÁNU
- (RO) GHIDAJ CU PROFIL „C“ PENTRU POARTA AUTOPORTANTĂ ÎN CONSOLĂ
- (HR) VODILICA „C“ PROFILA ZA KLIZNA DVORIŠNA VRATA
- (RU) НАПРАВЛЯЮЩИЙ РЕЛЬС / ПРОФИЛЬ «С» ДЛЯ ОТКАТНЫХ САМОНЕСУЩИХ ВОРОТ
- (SLO) "C" VODILO ZA SAMONOSNA DRNSNA VRATA
- (TR) KONSOL BAHÇE KAPISI İÇİN "C" PROFİL KIZAĞI
- (AR) للبوابة المدعومة "C" دعامة دليلية جانبية
- (CHN) 悬臂门"C"型导轨
- (MAL) PANDU PROFIL "C" UNTUK PINTU PAGAR JULUR
- (H) C-VEZETŐSÍN TOLÓKAPUHOZ
- (IL) קורה בפירויל "C" לשער קונדולי
- (BG) "C"-ОБРАЗНА РЕЛСА ЗА КОНЗОЛНА ВРАТА
- (KO) 캔틸레버 게이트용 "C"자형 프로필 가이드
- (SRB) VODICA „C“ PROFILA ZA SAMONOSIVU KAPIJU

Art.	CARRIAGE	GUIDE	L/1pc	1pc			CODE
			mm	kg	pcs	kg	
STAGE SB 6	SPEED S/SE/SK	UNGALVANIZED	6000	33	24	792	1700002
STAGE SB 5,6	SPEED S/SE/SK	UNGALVANIZED	5600	30,8	24	739,2	1700176
STAGE SB 3	SPEED S/SE/SK	UNGALVANIZED	3000	16,5	24	396	1700167
STAGE SB 2,8	SPEED S/SE/SK	UNGALVANIZED	2800	15,4	24	369,6	1720006
STAGE SB 1	SPEED S/SE/SK	UNGALVANIZED	1000	5,5	24	132	1720008
STAGE SZ 6	SPEED S/SE/SK	GALVANIZED	6000	33	24	792	1700003
STAGE SZ 5,6	SPEED S/SE/SK	GALVANIZED	5600	30,8	24	739,2	1700177
STAGE SZ 3	SPEED S/SE/SK	GALVANIZED	3000	16,5	24	396	1700168
STAGE SZ 2,8	SPEED S/SE/SK	GALVANIZED	2800	15,4	24	369,6	1720016
STAGE SZ 1	SPEED S/SE/SK	GALVANIZED	1000	5,5	24	132	1720018

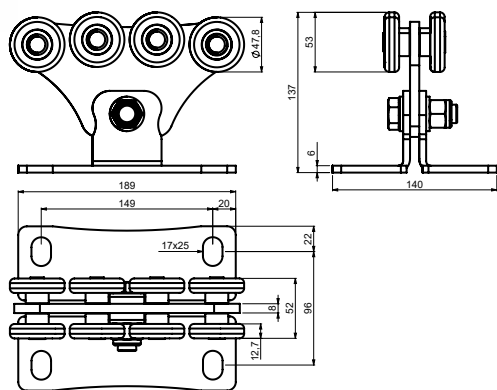
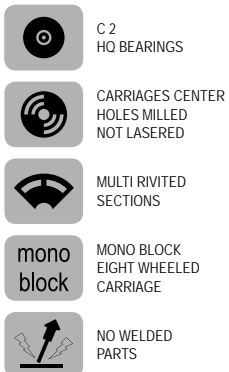

- (GB) EIGHT WHEELED CARRIAGE FOR CANTILEVER GATE  
 (D) ROLLAPPARAT MIT ACHT ROLLEN FÜR FREITRAGENDE SCHIEBETORE  
 (F) CHARIOT À HUIT ROUES POUR PORTAIL AUTOPORTANT  
 (E) CARRIL DE OCHO RUEDAS PARA PUERTA VOLADIZA  
 (P) CORREDIÇA DE OITO ROLDANAS PARA PORTÃO CANTILEVER  
 (I) CARRELLO A OTTO RUOTE PER CANCELLO AUTOPORTANTE  
 (DK) OTTE TRANSPORTHJUL TIL FRITTBÆRENDE PORT  
 (NL) ACHTVOUDIG WIELENBLOK VOOR VRIJDRAGENDE SCHUIFPOORT  
 (N) ÅTTEHJULS DRIVSKINNE TIL FRITTBÆRENDE PORT  
 (S) ÅTTAHJULIG VAGN FÖR FRIBÄRANDE GRIND  
 (FIN) KAHDEKSAN PYÖRÄN ALUSTA ULOKEKANNETEISEEN PORTTIIN  
 (PL) WÓZEK 8-ROLKOWY DO BRAM SAMONOŚNYCH  
 (SK) VOZÍK OSEM KOLIEČKOVÝ PRE POSUVNÚ SAMONOSNÚ BRÁNU  
 (EE) KAHEKSARATTALINE SUPORT KONSOOLVÁRAVA JAOKS  
 (LT) VEŽIMĖLIS GEMBINIAMS VARTAMS SU AŠTUONIAIS RATUKAIS  
 (LV) ASTOŅU RUĻĻU BLOKS KONSOLVEIDA VĀRTIEM

- (CZ) VOZÍK OSMIKOLOVÝ PRO POSUVNOU SAMONOSNOU BRÁNU  
 (RO) CĂRUCIOR PE OPT ROȚI PENTRU POARTA AUTOPORTANTĂ ÎN CONSOLĂ  
 (HR) NOSAČ S OSAM KOTAČA ZA KLIZNA DVORIŠNA VRATA  
 (RUS) ВОСЬМИКОЛЕСНАЯ РОЛИКОВАЯ ТЕЛЕЖКА ДЛЯ ОТКАТНЫХ САМОНЕСУЩИХ ВОРОТ  
 (SLO) VOZIČEK Z OSMIMI KOLESI ZA SAMONOSNA DRNSNA VRATA  
 (TR) KONSOL BAHÇE KAPISI İÇİN SEKİZ TEKERLEKLİ TAŞIYICI  
 (AR) عربة مزودة بثماني عجلات للوابت المدعجة  
 (CHN) 悬臂门八轮滑架  
 (MAL) PENYORONG LAPAN RODA UNTUK PINTU PAGAR JULUR  
 (H) NYOLCGÖRGÖS FUTÓKOCSI TOLÓKAPUHOZ  
 (IL) קרונית שמנונה גלגלים לשער קונדולי  
 (BG) КОЛИЧКА С ОСЕМ РОЛКИ ЗА КОНЗОЛНА ВРАТА  
 (KO) 8개 휠이 있는 캔틸레버 게이트용 이송대  
 (SRB) NOSAČ SA OSAM TOČKIČA ZA SAMONOSIVU KAPIJU

Art.	A	GUIDE	1pc		CODE
			kg	pcs	
SPEED SE	4000	STAGE SB/SZ	3,5	2	1700174

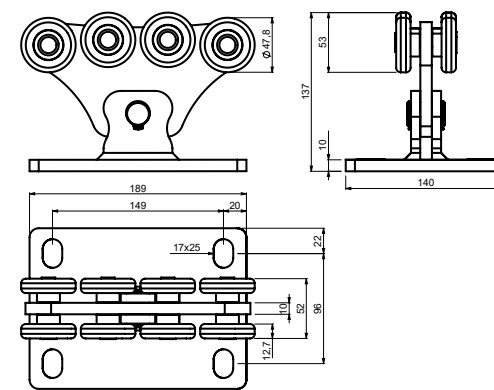
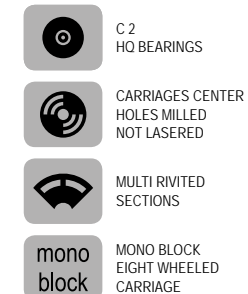





- (GB) EIGHT WHEELED CARRIAGE FOR CANTILEVER GATE  
 (D) ROLLAPPARAT MIT ACHT ROLLEN FÜR FREITRAGENDE SCHIEBETORE  
 (F) CHARIOT À HUIT ROUES POUR PORTAIL AUTOPORTANT  
 (E) CARRIL DE OCHO RUEDAS PARA PUERTA VOLADIZA  
 (P) CORREDIÇA DE OITO ROLDANAS PARA PORTÃO CANTILEVER  
 (I) CARRELLO A OTTO RUOTE PER CANCELLO AUTOPORTANTE  
 (DK) OTTE TRANSPORTHJUL TIL FRITTBÆRENDE PORT  
 (NL) ACHTVOUDIG WIELENBLOK VOOR VRIJDRAGENDE SCHUIFPOORT  
 (N) ÅTTEHJULS DRIVSKINNE TIL FRITTBÆRENDE PORT  
 (S) ÅTTAHJULIG VAGN FÖR FRIBÄRANDE GRIND  
 (FIN) KAHDEKSAN PYÖRÄN ALUSTA ULOKEKANNETEISEEN PORTTIIN  
 (PL) WÓZEK 8-ROLKOWY DO BRAM SAMONOŚNYCH  
 (SK) VOZÍK OSEM KOLIEČKOVÝ PRE POSUVNÚ SAMONOSNÚ BRÁNU  
 (EE) KAHEKSARATTALINE SUPORT KONSOOLVÁRAVA JAOKS  
 (LT) VEŽIMĖLIS GEMBINIAMS VARTAMS SU AŠTUONIAIS RATUKAIS  
 (LV) ASTOŅU RUĻĻU BLOKS KONSOLVEIDA VĀRTIEM

- (CZ) VOZÍK OSMIKOLOVÝ PRO POSUVNOU SAMONOSNOU BRÁNU  
 (RO) CĂRUCIOR PE OPT ROȚI PENTRU POARTA AUTOPORTANTĂ ÎN CONSOLĂ  
 (HR) NOSAČ S OSAM KOTAČA ZA KLIZNA DVORIŠNA VRATA  
 (RUS) ВОСЬМИКОЛЕСНАЯ РОЛИКОВАЯ ТЕЛЕЖКА ДЛЯ ОТКАТНЫХ САМОНЕСУЩИХ ВОРОТ  
 (SLO) VOZIČEK Z OSMIMI KOLESI ZA SAMONOSNA DRNSNA VRATA  
 (TR) KONSOL BAHÇE KAPISI İÇİN SEKİZ TEKERLEKLİ TAŞIYICI  
 (AR) عربة مزودة بثماني عجلات للوابت المدعجة  
 (CHN) 悬臂门八轮滑架  
 (MAL) PENYORONG LAPAN RODA UNTUK PINTU PAGAR JULUR  
 (H) NYOLCGÖRGÖS FUTÓKOCSI TOLÓKAPUHOZ  
 (IL) קרונית שמנונה גלגלים לשער קונדולי  
 (BG) КОЛИЧКА С ОСЕМ РОЛКИ ЗА КОНЗОЛНА ВРАТА  
 (KO) 8개 휠이 있는 캔틸레버 게이트용 이송대  
 (SRB) NOSAČ SA OSAM TOČKIČA ZA SAMONOSIVU KAPIJU

Art.	A	GUIDE	1pc		CODE
			kg	pcs	
SPEED S	4500	STAGE SB/SZ	4,7	2	1700001



-  SUITABLE FOR INCLINED SURFACE INSTALLATION
-  ASYMMETRIC EIGHT WHEELED CARRIAGE
-  C 2 HQ BEARINGS
- mono block** MONO BLOCK EIGHT WHEELED CARRIAGE
-  CARRIAGES CENTER HOLES MILLED NOT LASERED
-  MULTI RIVETED SECTIONS

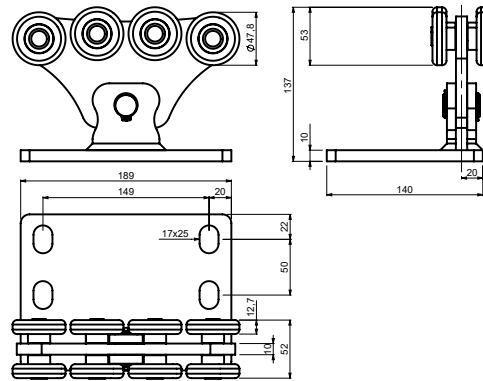

- (GB) EIGHT WHEELED CARRIAGE FOR CANTILEVER GATE
- (D) ROLLAPPARAT MIT ACHT ROLLEN FÜR FREITRAGENDE SCHIEBETORE
- (F) CHARIOT À HUIT ROUES POUR PORTAIL AUTOPORTANT
- (E) CARRIL DE OCHO RUEDAS PARA PUERTA VOLADIZA
- (P) CORREDIÇA DE OITO ROLDANAS PARA PORTÃO CANTILEVER
- (I) CARRELLO A OTTO RUOTE PER CANCELLO AUTOPORTANTE
- (DK) OTTE TRANSPORTHJUL TIL FRITTBÆRENDE PORT
- (NL) ACHTVOUDIG WIELENBLOK VOOR VRIJDRAGENDE SCHUIFPOORT
- (N) ÅTTA HJULIG VAGN FÖR FRIBÄRANDE GRIND
- (S) ÅTTA HJULIG VAGN FÖR FRIBÄRANDE GRIND
- (FIN) KAHDEKSAN PYÖRÄN ALUSTA ULOKEKANNETIESEEN PORTTIIN
- (PL) WÓZEK 8-ROLKOWY DO BRAM SAMONOŚNYCH
- (SK) VOZÍK OSEM KOLIEČKOVÝ PRE POSUVNÚ SAMONOSNÚ BRÁNU
- (EE) KAHEKSARATTA LINE SUPOORT KONSOLVÄRAVA JAOKS
- (LT) VEŽIMĖLIS GEMBINIAMS VARTAMS SU AŠTUONIAMS RATUKAIS
- (LV) ASTŌNU RULĻU BLOKS KONSOLVEIDA VĀRTIEM

- (CZ) VOZÍK OSMIKOLOVÝ PRO POSUVNOU SAMONOSNOU BRÁNU
- (RO) CĂRUCIOR PE OPT ROȚI PENTRU POARTA AUTOPORTANTĂ ÎN CONSOLĂ
- (HR) NOSAČ S OSAM KOTAČA ZA KLIZNA DVORIŠNA VRATA
- (RUS) ВОСЬМИКОЛЕСНАЯ РОЛИКОВАЯ ТЕЛЕЖКА ДЛЯ ОТКАТНЫХ САМОНЕСУЩИХ ВОРОТ
- (SLO) VOZIČEK Z OSMIMI KOLESI ZA SAMONOSNA DRSNA VRATA
- (TR) KONSOL BAHÇE KAPISI İÇİN SEKİZ TEKERLEKLİ TAŞIYICI
- (AR) عربة مزودة بشاسي عجلات اللولب المدعومة
- (CHN) 悬臂门八轮滑架
- (MAL) PENYORONG LAPAN RODA UNTUK PINTU PAGAR JULUR
- (H) NYOLCGÖRGÖS FUTÓKOCSI TOLÓKAPUHOZ
- (IL) קרונית שמנונה גלגלים לשער קנדולי
- (BG) КОЛИЧКА С ОСЕМ РОЛКИ ЗА КОНЗОЛНА ВРАТА
- (KO) 8개 휠이 있는 캔틸레버 게이트용 이송대
- (SRB) NOSAČ SA OSAM TOČKIĆA ZA SAMONOSIVU KAPIJU

Art.	A	GUIDE	1pc				CODE
			kg	pcs	kg		
SPEED SK	4500	STAGE SB/SZ	4,7	2	9,4		1700189

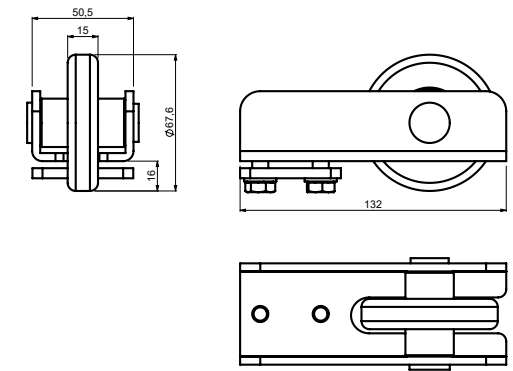

- (GB) GUIDE SUPPORT WHEEL FOR CANTILEVER GATE
- (D) STÜTZRAD FÜR FREITRAGENDE SCHIEBETORE
- (F) ROUE DE SUPPORT DE GUIDE POUR PORTAIL AUTOPORTANT
- (E) RUEDA CON SOPORTE DE GUÍA PARA PUERTA VOLADIZA
- (P) ROLDANA DE SUPORTE GUIA PARA PORTÃO CANTILEVER
- (I) RUOTA DI SOSTEGNO DELLA GUIDA PER CANCELLO AUTOPORTANTE
- (DK) VANGESTØTTEHJUL TIL FRITTBÆRENDE PORT
- (NL) DRAAGWIEL VOOR GELEIDING VRIJDRAGENDE SCHUIFPOORT
- (N) STYRESKINNE FOR STØTTEHJUL TIL FRITTBÆRENDE PORT
- (S) STÖDHJUL FÖR FRIBÄRANDE GRIND
- (FIN) OHJAIMEN TUKIPYÖRÄ ULOKEKANNETIESEEN PORTTIIN
- (PL) ROLKA NAJAZDOWA DO BRAM SAMONOŚNYCH
- (SK) NÁBEH S KLADKOU PRE POSUVNÚ SAMONOSNÚ BRÁNU
- (EE) JUHI TUGIRATAS KONSOLVÄRAVA JAOKS
- (LT) KREIPTUVO ATRAMOS RATUKAS GEMBINIAMS VARTAMS
- (LV) VADOTNES BALSTA RULLĪTIS KONSOLVEIDA VĀRTIEM

- (CZ) NÁBEH S KLADKOU PRO POSUVNOU SAMONOSNOU BRÁNU
- (RO) ROATĂ DE SUSȚINERE GHIDAJ PENTRU POARTA AUTOPORTANTĂ ÎN CONSOLĂ
- (HR) NOSIVI KOTAČ VODILICE ZA KLIZNA DVORIŠNA VRATA
- (RUS) КОНЦЕВОЙ РОЛИК ДЛЯ ОТКАТНЫХ САМОНЕСУЩИХ ВОРОТ
- (SLO) PODPORNO KOLO VODILA ZA SAMONOSNA DRSNA VRATA
- (TR) KONSOL BAHÇE KAPISI İÇİN KIZAK DESTEK TEKERLEĞİ
- (AR) عجلة دعمية نظيلية للولاية المدعومة
- (CHN) 悬臂门导轨支轮
- (MAL) RODA SOKONGAN PANDU UNTUK PINTU PAGAR JULUR
- (H) VEZETŐ, MEGTÁMASZTÓ GÖRGŐ TOLÓKAPUHOZ
- (IL) גלגל תומך לשער קנדולי
- (BG) РОЛКА ЗА РЕЛСА ЗА КОНЗОЛНА ВРАТА
- (KO) 캔틸레버 게이트용 가이드 지지 휠
- (SRB) NOSEĆI TOČKIĆ VODICE ZA SAMONOSIVU KAPIJU

Art.	GUIDE	1pc				CODE
		kg	pcs	kg		
RUN S	STAGE SB/SZ	0,97	10	9,7		1700004



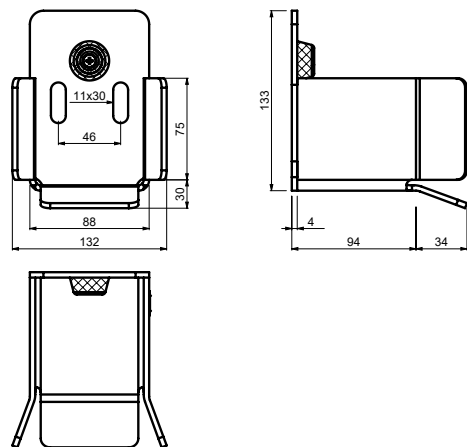

- (GB) END STOP FOR CANTILEVER GATE
- (D) EINLAUFSCHUH FÜR FREITRAGENDE SCHIEBETORE
- (F) BUTÉE POUR PORTAIL AUTOPORTANT
- (E) TOPE FINAL PARA PUERTA VOLADIZA
- (P) BATEANTE PARA PORTÃO CANTILEVER
- (I) FERMO DI FINE CORSA PER CANCELLO AUTOPORTANTE
- (DK) ENDESTOP TIL FRITTBÆRENDE PORT
- (NL) EINDSTOP VOOR VRIJDRAGENDE SCHUIFPOOR
- (N) ENDESTOPPER FOR FRITTBÆRENDE PORT
- (S) ÄNDSTOPP FÖR FRIBÄRANDE GRIND
- (FIN) PÄÄTYPYSÄYTIN ULOKEKANNETTEISEEN PORTTIIN
- (PL) ODBOJNIK DO BRAM SAMONOŚNYCH
- (SK) DOJAZDOVÁ KAPSA SPODNÁ PRE POSUVNÚ SAMONOSNÚ BRÁNU
- (EE) OTSALÕPP KONSOLVÄRAVA JAOKS
- (LT) GALINIS RIBOKLIS GEMBINIAMS VARTAMS
- (LV) GALA AIZTURIS KONSOLVEIDA VÄRTIEM

- (CZ) DOJAZDOVÁ KAPSA SPODNÍ PRO POSUVNOU SAMONOSNOU BRÁNU
- (RO) OPRITOR CURSĂ PENTRU POARTA AUTOPORTANTĂ ÎN CONSOLĂ
- (HR) GRANIČNIK ZA KLIZNA DVORIŠNA VRATA
- (RUS) УЛАВЛИВАТЕЛЬ НИЖНИЙ ДЛЯ ОТКАТНЫХ САМОНЕСУЩИХ ВОРОТ
- (SLO) ZAUSTAVLJALNIK ZA SAMONOSNA DRŠNA VRATA
- (TR) KONSOL BAHÇE KAPISI İÇİN UÇ TESPİT PARÇASI
- (AR) المدع الطرفي للبوابة المدعومة
- (CHN) 悬臂门终点挡块
- (MAL) PENYENDAL Hujung Untuk Pintu Pagar Julur
- (H) ÜTKÖZŐ TOLÓKAPUHOZ
- (IL) מקביל קצה לשער קונדולי
- (BG) СТОПЕР ЗА КОНЗОЛНА ВРАТА
- (KO) 캔틸레버 게이트용 종단 정지대
- (SRB) GRANIČNIK ZA SAMONOSIVU KAPIJU

Art.	GUIDE	1pc			CODE
		kg	pcs	kg	
LAST S	STAGE SB/SZ	1,24	2	2,48	1700005

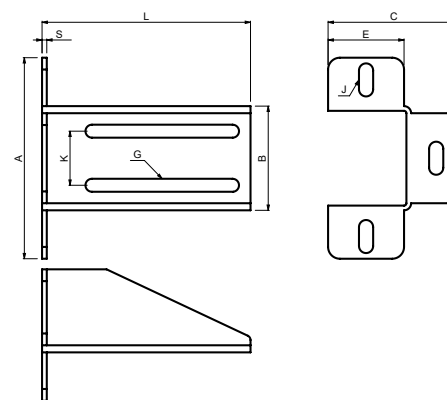
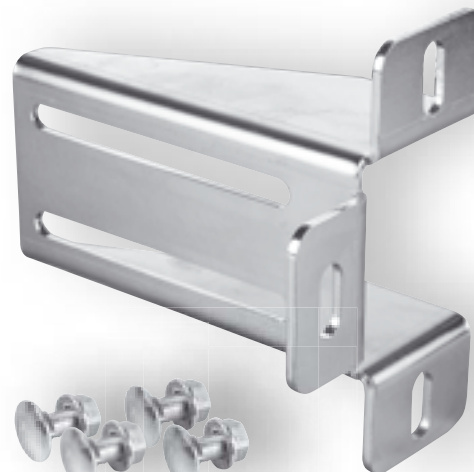

- (GB) END STOP BRACKET
- (D) KONSOLE FÜR EINLAUFSCHUH
- (F) ÉTRIER POUR BUTÉE
- (E) SOPORTE DE TOPE FINAL
- (P) SUPORTE DE BATEANTE
- (I) STAFFA PER FERMO DI FINE CORSA
- (DK) ENDESTOP BESLAG
- (NL) EINDSTOP BEVESTIGINGSBEUGEL
- (N) STOPPEBRACKET
- (S) ÄNDSTOPP KONSOL
- (FIN) PÄÄTYPYSÄYTTIMEN KANNATIN
- (PL) WSPORNIK ODBOJNIKA
- (SK) KONZOLA PRE DOJAZDOVÚ KAPSU
- (EE) OTSALÕPU KLAMBER
- (LT) GALINIO RIBOKLIO GEMBĖ
- (LV) GALA AIZTURA KRONŠTEINS

- (CZ) KONZOLA PRO DOJAZDOVOU KAPSU
- (RO) OPRITOR CURSĂ CONSOLĂ
- (HR) KONZOLA GRANIČNIKA
- (RUS) КРОНШТЕЙН УЛАВЛИВАТЕЛЯ
- (SLO) OPORNIK ZAUSTAVLJALNIKA
- (TR) UÇ TESPİT PARÇASI DİRSEĞİ
- (AR) سنادة المدع الطرفي
- (CHN) 终点挡块支座
- (MAL) PENDAKAP PENYENDAL Hujung
- (H) ÜTKÖZŐ-KERET
- (IL) תופסן למקביל קצה
- (BG) СКОБА ЗА СТОПЕР
- (KO) 종단 정지대 브라켓
- (SRB) KONZOLA GRANIČNIKA

Art.	L	A	B	C	E	G	J	K	S	END STOP	1pc			CODE
											kg	pcs	kg	
mm														
PARK	175	170	88	95	50	11X132	12X30	46	4	LAST/PADDOCK	1,11	2	2,22	1700006
PARK 240	245	170	88	95	50	11X200	12X30	46	4	LAST/PADDOCK	1,35	2	2,7	1700196

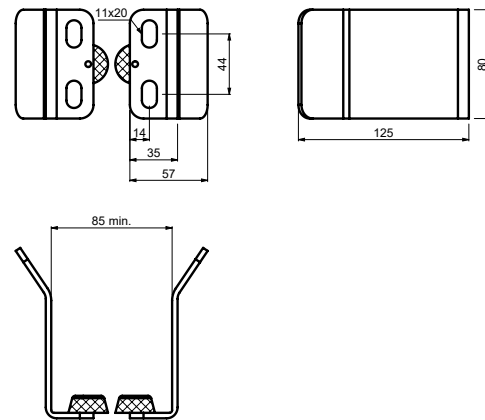

- (GB) END STOP
- (D) ENDANSCHLAG
- (F) BUTÉE
- (E) TOPE FINAL
- (P) FIM DE CURSO
- (I) ARRESTO TERMINALE
- (DK) ENDESTOPP
- (NL) EINDSTOP
- (N) ENDESTOPP
- (S) ÄNDSTOPP
- (FIN) RAJOITIN
- (PL) ZDERZAK KRAŃCOWY
- (SK) DORAZ
- (EE) OTSA LÖPPER
- (LT) GALINIS RIBOKLIS
- (LV) GALA AIZTURIS

- (CZ) KONCOVÝ DORAZ
- (RO) OPRITOR FINAL
- (HR) GRANIČNIK
- (RUS) КОНЦЕВОЙ УПОР
- (SLO) KONČNI ELEMENT
- (TR) UÇ TIPASI
- (AR) نقطة التوقف
- (CHN) 限位挡块
- (MAL) ADANG Hujung
- (H) VÉGÜTKÖZŐ
- (IL) מקבל קצה
- (BG) ЦТОПЕР
- (KO) 종단 장치대
- (SRB) GRANIČNIK

Art.	BRACKET	1pc			CODE
		kg	pcs	kg	
PADDOCK SM	PARK/PARK 240	0,78	2	1,56	1700194

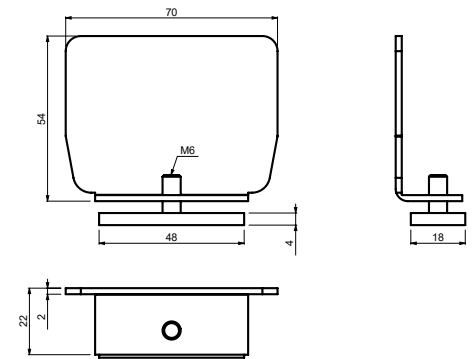

- (GB) GUIDE END CAP WITH SCREW, INDEPENDENT
- (D) ABSCHLUSSKAPPE FÜR „C“ PROFIL AUS STAHL MIT SCHRAUBE
- (F) CACHE D'EMBOÛT DE GUIDE AVEC VIS, INDÉPENDANT
- (E) TOPE FINAL DE GUÍA CON TUERCA, INDEPENDIENTE
- (P) TAMPA FINAL GUIA COM PARAFUSO, INDEPENDENTE
- (I) COPERTURA TERMINALE DELLA GUIDA CON VITE, INDIPENDENTE
- (DK) VANGEENDEHÆTTE MED SKRUE, UAFHÆNGIG
- (NL) GELEIDER EINDKAP MET SCHROEF, ONAFHANKELIJK
- (N) ENDEBESLAG FOR SKINNE MED SKRUE, UAVHENGIG
- (S) GEJD SKYDDSKÅPA MED SKRUV, OBEROENDE
- (FIN) OHJAIMEN PÄÄN RUUVILLINEN KANSI, ERILLINEN
- (PL) ZASŁEPKA KOŃCOWA SZYNY ZE ŚRUBĄ, NIEZALEŻNA
- (SK) ZÁSLEPKA PRE NOSNÝ „C“ PROFIL, NEZÁVISLÁ SO SKRUTKOU
- (EE) JUHIKU OTSAKORK KRUVIGA, ERALDI
- (LT) GALINIS KREIPTUVO DANGTELIS SU SRIEGIU, ATSKIRAS
- (LV) VADOTNES GALA VĀKS AR SKRŪVI, NEATKARĪGS

- (CZ) ZÁSLEPKA PRO ŠÍŇU „C“ PROFIL, NEZÁVISLÁ SE ŠROUBEM
- (RO) OPRITOR CURSĂ ACOPERIRE GHIDAJ CU FILET, INDEPENDENT
- (HR) ČEP VODILICE S VIJKOM, NEOVISAN
- (RUS) ЗАГЛУШКА НАПРАВЛЯЮЩЕГО РЕЛЬСА «С», НЕЗАВИСИМАЯ, С ВИНТОМ
- (SLO) ZAKLJUČNI POKROV VODILA Z VIJAKOM, NEODVISEN
- (TR) VIDALI KIZAK UÇ LASTIĞI, BAĞIMSIZ
- (AR) غطاء طرفي دليلي مع برغي، مستقل
- (CHN) 导轨独立式螺钉紧固端盖
- (MAL) PENUTUP HUJUNG PANDU DENGAN SKRU, BEBAS
- (H) VEZETŐSÍN LEZÁRÓ-ELEM CSAVARRAL, FÜGGETLEN
- (IL) מססה קצה קורה קונדוליט עם בורג, עצמאי
- (BG) КРАЙНА КАПАЧКА ЗА РЕЛСА С ВИНТ, САМОСТОЯТЕЛНА
- (KO) 나사가 있는 가이드 캡, 독립식
- (SRB) ČEP VODICE SA ZAVRTNEM, NEZAVISAN

Art.	GUIDE	1pc			CODE
		kg	pcs	kg	
PILOT SN	STAGE SB/SZ	0,1	10	1	1700007

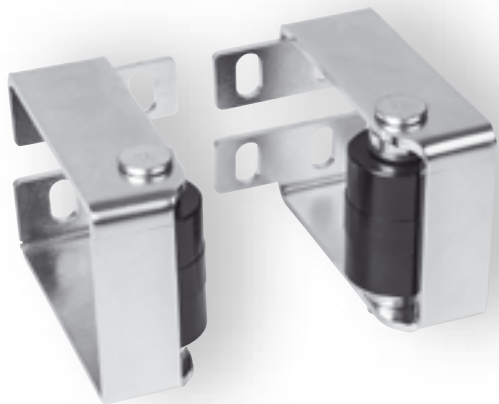

CAIS INNOVATION

FAIL-SAFE ROLLER MECHANISM

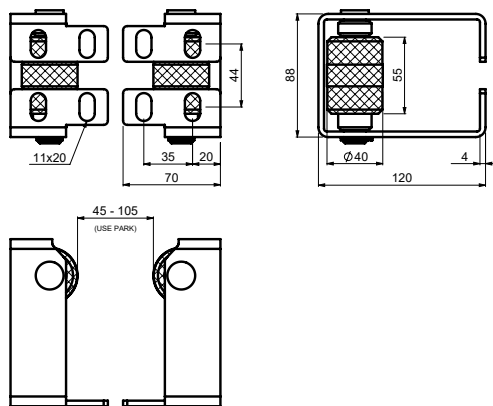

- (GB) END STOP WITH ROLLER
- (D) ENDANSCHLAG MIT ROLLE
- (F) BUTÉE AVEC ROULEAU
- (E) TOPE FINAL CON RODILLO
- (P) FIM DE CURSO COM ROLO
- (I) ARRESTO TERMINALE CON RULLO
- (DK) ENDESTOP MED VALSE
- (NL) EINDSTOP MET ROLLEN
- (N) ENDESTOPP MED RULLE
- (S) ÄNDSTOPP MED RULLE
- (FIN) RAJOITIN RULLALLA
- (PL) ZDERZAK KRAŃCOWY Z ROLKĄ
- (SK) DORAZ S VALČEKOM
- (EE) OTSALÕPP RULLIKUGA
- (LT) GALINIS RIBOKLIS SU RITINĖLIU
- (LV) GALA AIZTURIS AR RULLĪTI

- (CZ) KONCOVÝ DORAZ S KLADKOU
- (RO) OPRITOR FINAL CU ROLĂ
- (HR) GRANIČNIK S VALJKOM
- (RUS) КОНЦЕВОЙ УПОР С РОЛИКОМ
- (SLO) KONČNI ELEMENT S KOLESCEM
- (TR) MAKARALI UÇ TIPASI
- (AR) نقطة التوقف المزودة بكرّة
- (CHN) 帶轆子的限位擋塊
- (MAL) ADANG Hujung DENGAN PENGGELEK
- (H) VÉGÜTKÖZŐ GÖRGŐVEL
- (IL) מקבל מתחנן עם גלגלי אוקולון
- (BG) СТОПЕР С РОЛКА
- (KO) 롤러가 있는 종단 장치대
- (SRB) GRANIČNIK SA VALJKOM

Art.	BRACKET	1pc		CODE
		kg	pcs	
PADDOCK 2	PARK/PARK 240	1,4	2	1700182

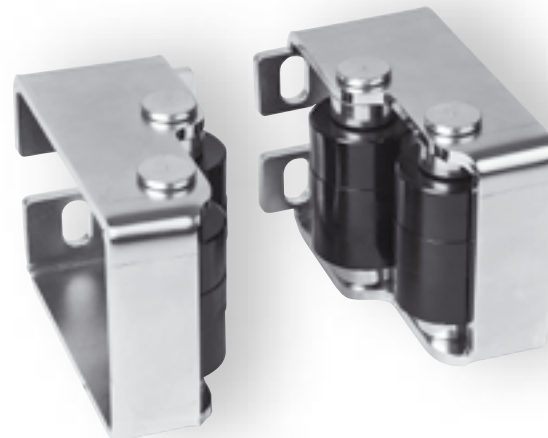

CAIS INNOVATION

FAIL-SAFE ROLLER MECHANISM

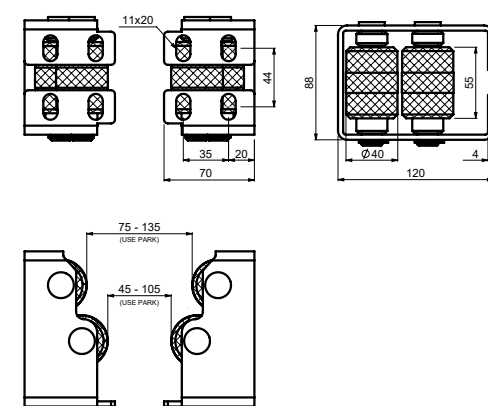

- (GB) END STOP WITH ROLLER
- (D) ENDANSCHLAG MIT ROLLE
- (F) BUTÉE AVEC ROULEAU
- (E) TOPE FINAL CON RODILLO
- (P) FIM DE CURSO COM ROLO
- (I) ARRESTO TERMINALE CON RULLO
- (DK) ENDESTOP MED VALSE
- (NL) EINDSTOP MET ROLLEN
- (N) ENDESTOPP MED RULLE
- (S) ÄNDSTOPP MED RULLE
- (FIN) RAJOITIN RULLALLA
- (PL) ZDERZAK KRAŃCOWY Z ROLKĄ
- (SK) DORAZ S VALČEKOM
- (EE) OTSALÕPP RULLIKUGA
- (LT) GALINIS RIBOKLIS SU RITINĖLIU
- (LV) GALA AIZTURIS AR RULLĪTI

- (CZ) KONCOVÝ DORAZ S KLADKOU
- (RO) OPRITOR FINAL CU ROLĂ
- (HR) GRANIČNIK S VALJKOM
- (RUS) КОНЦЕВОЙ УПОР С РОЛИКОМ
- (SLO) KONČNI ELEMENT S KOLESCEM
- (TR) MAKARALI UÇ TIPASI
- (AR) نقطة التوقف المزودة بكرّة
- (CHN) 帶轆子的限位擋塊
- (MAL) ADANG Hujung DENGAN PENGGELEK
- (H) VÉGÜTKÖZŐ GÖRGŐVEL
- (IL) מקבל מתחנן עם גלגלי אוקולון
- (BG) СТОПЕР С РОЛКА
- (KO) 롤러가 있는 종단 장치대
- (SRB) GRANIČNIK SA VALJKOM

Art.	BRACKET	1pc		CODE
		kg	pc	
PADDOCK 4	PARK/PARK 240	2,1	1	1700191

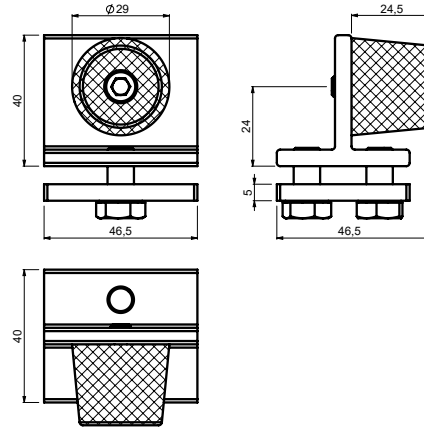
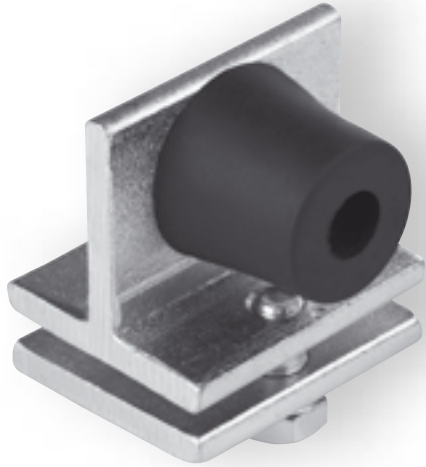

- (GB) INTERNAL GUIDE END STOP
- (D) INNENANSCHLAG FÜR „C“ PROFIL
- (F) BUTÉE INTERNE POUR GUIDE
- (E) TOPE FINAL DE GUÍA INTERNA
- (P) BATENTE GUIA INTERNA
- (I) FERMO DI FINE CORSA DELLA GUIDA INTERNA
- (DK) INTERN VANGEENDESTOP
- (NL) INTERNE GELEIDER EINDSTOP
- (N) ENDESTOPPER TIL INNVEDIG SKINNE
- (S) INTERNT GEJÄNDSTOPP
- (FIN) SISÄINEN OHJAIMEN PÄÄN PYSÄYTIN
- (PL) WEWNĘTRZNY ODBOJNIK SZYNY
- (SK) DORAZ VNÚTORNÝ PRE NOSNÝ „C“ PROFIL
- (EE) SISEJUHUKU OTSALÕPP
- (LT) VIDINIO KREIPTUVO GALINIS RIBOKLIS
- (LV) IEKŠĒJAIS VADOTNES GALA AIZTURIS

- (CZ) DORAZ VNITŘNÍ PRO ŠINU „C“ PROFIL
- (RO) GHIDAJ CAPĂT FINAL INTERN
- (HR) UNUTARNJI GRANIČNIK VODILICE
- (RUS) ВНУТРЕННИЙ ОГРАНИЧИТЕЛЬ НАПРАВЛЯЮЩЕГО РЕЛЬСА «С»
- (SLO) ZAUSTAVLJALNIK NOTRANJEGA VODILA
- (TR) DAHİLİ KIZAK UÇ TESPİT PARÇASI
- (AR) مقع طرفي نهائي داخلي
- (CHN) 内导轨终点挡块
- (MAL) PENYENDAL Hujung PANDU DALAM
- (H) VEZETŐSÍN BELSŐ ÜTKÖZŐ
- (IL) מעצור פנימי גומי לקרוה
- (BG) ВЪТРЕШЕН СТОПЕР ЗА РЕЛСА
- (KO) 내부 가이드 종단 정지대
- (SRB) UNUTRAŠNJI GRANIČNIK VODICE

Art.	GUIDE	1pc		CODE
		kg	pcs	
FINISH S	STAGE SB/SZ	0,23	20	1700008

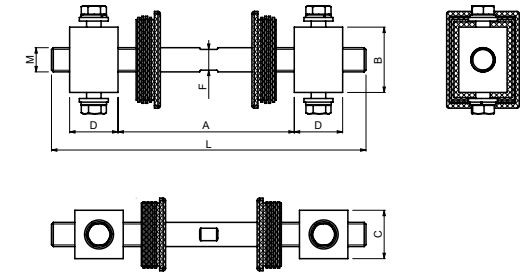

- (GB) ADJUSTABLE TENSION BAR FOR CANTILEVER GATE
- (D) EINSTELLBARE ZUGSTANGE FÜR AUSLEGERTOR
- (F) BARRE DE TENSION RÉGLABLE POUR PORTAIL COULISSANT AUTOPORTANT
- (E) BARRA TENSORA AJUSTABLE PARA PORTÓN EN VOLADIZO
- (P) BARRA DE TENSÃO AJUSTÁVEL PARA PORTÃO CANTILEVER
- (I) TIRANTE DI REGOLAZIONE PER CANCELLO AUTOPORTANTE
- (DK) JUSTERBAR SPÆNDINGSSTANG TIL FRITBÆRENDE PORT
- (NL) VERSTELBARE SPANNINGSBALK VOOR SCHUIFPOORT
- (N) JUSTERBAR STREKKSTANG FOR RULLEPORT
- (S) JUSTERBAR SPÄNNINGSSTÅNG FÖR FRIBÄRANDE GRIND
- (FIN) SÄÄDETTÄVÄ KIRISTYSTANKO ULOKEPORTTIIN
- (PL) REGULOWANA LISTWA NAPINAJĄCA DO BRAMY SAMONOSNEJ
- (SK) NASTAVITELNÁ ŤAŽNÁ TYČ PRE SAMONOSNÉ BRÁNY
- (EE) REGULEERITAV PINGUTUSTALA KONSOOLVÄRAVA JAOKS
- (LT) REGULIUOJAMA TRAUKĖ GEMBINIAMS VARTAMS
- (LV) REGULĒJAMS STIEPNIS KONSOLVEIDA VĀRTIEM

- (CZ) TENZNÍ TYČ S REGULACÍ PRO POSUVNOU SAMONOSNOU BRÁNU
- (RO) BARĂ DE TENSIUNE REGLABILĂ PENTRU POARTĂ ÎN CONSOLĂ
- (HR) PRILAGODLJIVA STEZNA ŠIPKA ZA NOSIVA VRATA
- (RUS) БАРĂ DE TENSIUNE REGLABILĂ PENTRU POARTĂ ÎN CONSOLĂ
- (SLO) NASTAVLJIV NAPENJALNI VZVOD ZA SAMONOSNA DRSNNA VRATA
- (TR) MANİVELA KAPI İÇİN AYARLANABİLİR GERİLİM ÇUBUĞU
- (AR) قضيب الشد القابل للتعديل لوابية الكترول
- (CHN) 可调节悬臂门拉杆
- (MAL) BAR TEGANGAN BOLEH LARAS UNTUK GET JULUR
- (H) ÁLLÍTHATÓ FESZÍTŐRÖD TOLÓKAPUHOZ
- (IL) מוט מתחם מתכוונן לשער קנולוי
- (BG) РЕГУЛИРУЕМ ОБТЕГАЧ ЗА КОНЗОЛНА ВРАТА
- (KO) 캔틸레버 게이트용 조절식 인장대
- (SRB) PODESIVA ZATEZNA ŠIPKA ZA SAMONOSIVU KAPIJU

Art.	□	L	A min./max.	B	C	D	M	F	1pc			CODE
									kg	pcs	kg	
DIAGON 60	60x40	260	125 - 170	34	40	40	M20	17	1,39	2	2,78	1700237
DIAGON 80	80x60/60x60	260	125 - 180	54	40	40	M20	17	1,95	2	3,9	1700238

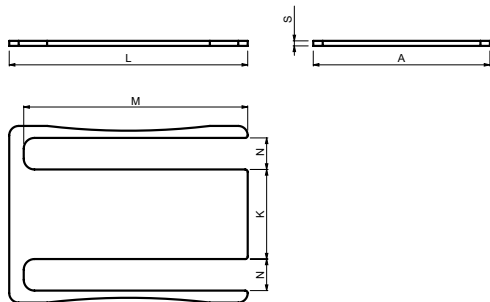

- (GB) WASHER FOR CANTILEVER CARRIAGE
- (D) UNTERLEGSCHIBE FÜR AUSLEGERSCHLITTEN
- (F) RONDELLE POUR CHARIOT CANTILEVER
- (E) TUERCA PARA CARRO EN VOLADIZO
- (P) ARRUELA PARA TRANSPORTE DE CANTILEVER
- (I) RONDELLA PER CARRELLO CANCELLO AUTOPORTANTE
- (DK) SKIVE TIL FRITBÆRENDE PORT
- (NL) RING VOOR SCHUIFWAGEN
- (N) SKIVE FOR RULLEPORTVOGN
- (S) BRICKA FÖR FRIBÄRANDE GRINDVAGN
- (FIN) ALUSLEVY ULOKETELINEESEEN
- (PL) PODKŁADKA DO WÓZKA BRAMY SAMONOŚNEJ
- (SK) PODLOŽKA PRE SAMONOSNÝ NOSNÍK
- (EE) SEIB KONSOOLALUSE JAOKS
- (LT) POVERŽLĖ GEMBINIŲ VARTŲ VEŽIMĖLIUI
- (LV) PĀPLĀKSNE KONSOLĒS NESOŠĀJAM RUĻĻU BLOKAM

- (CZ) PODLOŽKA PRO VOZÍK
- (RO) ȘAIBĂ PENTRU SISTEMUL DE CULISARE ÎN CONSOLĂ
- (HR) PODLOŠKA ZA NOSIVO PODVOZJE
- (RUS) ШАЙБА ДЛЯ РОЛИКОВЫХ ТЕЛЕЖЕК САМОНЕСУЩИХ ВОРОТ
- (SLO) PODLOŽKA ZA VOZIČEK
- (TR) MANIVELA TAŞIYICISI İÇİN RONDELA
- (AR) حلبة لثوابية الكابول
- (CHN) 悬臂架垫片
- (MAL) SESENDAL UNTUK PEMBAWA JULUR
- (H) ALÁTÉT TOLÓKAPU FUTÓKOCSIHOZ
- (IL) חסכת ללגלגים לקונדול
- (BG) ВЛОЖКА ЗА КОНЗОЛНА КОЛИЧКА
- (KO) 캔틸레버 이송대용 와셔
- (SRB) PODLOŠKA ZA SAMONOSIVU KARIJU

Art.	L	A	K	M	N	S	CARRIAGE	1pc	CODE			
								kg	pcs	kg		
	mm											
DESK SE 2	189	140	71	178	25	2	SPEED SE	0,26	6	1,56	1700314	
DESK SE 4	189	140	71	178	25	4	SPEED SE	0,52	6	3,12	1700315	
DESK SE 6	189	140	71	178	25	6	SPEED SE	0,78	6	4,68	1700316	

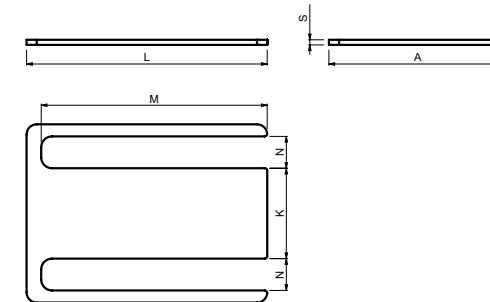

- (GB) WASHER FOR CANTILEVER CARRIAGE
- (D) UNTERLEGSCHIBE FÜR AUSLEGERSCHLITTEN
- (F) RONDELLE POUR CHARIOT CANTILEVER
- (E) TUERCA PARA CARRO EN VOLADIZO
- (P) ARRUELA PARA TRANSPORTE DE CANTILEVER
- (I) RONDELLA PER CARRELLO CANCELLO AUTOPORTANTE
- (DK) SKIVE TIL FRITBÆRENDE PORT
- (NL) RING VOOR SCHUIFWAGEN
- (N) SKIVE FOR RULLEPORTVOGN
- (S) BRICKA FÖR FRIBÄRANDE GRINDVAGN
- (FIN) ALUSLEVY ULOKETELINEESEEN
- (PL) PODKŁADKA DO WÓZKA BRAMY SAMONOŚNEJ
- (SK) PODLOŽKA PRE SAMONOSNÝ NOSNÍK
- (EE) SEIB KONSOOLALUSE JAOKS
- (LT) POVERŽLĖ GEMBINIŲ VARTŲ VEŽIMĖLIUI
- (LV) PĀPLĀKSNE KONSOLĒS NESOŠĀJAM RUĻĻU BLOKAM

- (CZ) PODLOŽKA PRO VOZÍK
- (RO) ȘAIBĂ PENTRU SISTEMUL DE CULISARE ÎN CONSOLĂ
- (HR) PODLOŠKA ZA NOSIVO PODVOZJE
- (RUS) ШАЙБА ДЛЯ РОЛИКОВЫХ ТЕЛЕЖЕК САМОНЕСУЩИХ ВОРОТ
- (SLO) PODLOŽKA ZA VOZIČEK
- (TR) MANIVELA TAŞIYICISI İÇİN RONDELA
- (AR) حلبة لثوابية الكابول
- (CHN) 悬臂架垫片
- (MAL) SESENDAL UNTUK PEMBAWA JULUR
- (H) ALÁTÉT TOLÓKAPU FUTÓKOCSIHOZ
- (IL) חסכת ללגלגים לקונדול
- (BG) ВЛОЖКА ЗА КОНЗОЛНА КОЛИЧКА
- (KO) 캔틸레버 이송대용 와셔
- (SRB) PODLOŠKA ZA SAMONOSIVU KARIJU

Art.	L	A	K	M	N	S	CARRIAGE	1pc	CODE		
								kg	pcs	kg	
	mm										
DESK S 2	189	140	71	178	25	2	SPEED S	0,29	6	1,74	1700317
DESK S 4	189	140	71	178	25	4	SPEED S	0,58	6	3,48	1700318
DESK S 6	189	140	71	178	25	6	SPEED S	0,87	6	5,22	1700319

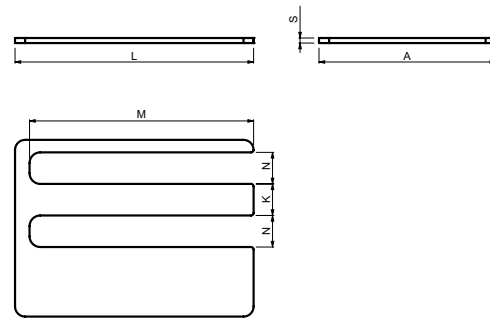

- (GB) WASHER FOR CANTILEVER CARRIAGE
- (D) UNTERLEGSCHIBE FÜR AUSLEGERSCHLITTEN
- (F) RONDELLE POUR CHARIOT CANTILEVER
- (E) TUERCA PARA CARRO EN VOLADIZO
- (P) ARRUELA PARA TRANSPORTE DE CANTILEVER
- (I) RONDELLA PER CARRELLO CANCELLO AUTOPORTANTE
- (DK) SKIVE TIL FRITBÆRENDE PORT
- (NL) RING VOOR SCHUIFWAGEN
- (N) SKIVE FOR RULLEPORTVOGN
- (S) BRICKA FÖR FRIBÄRANDE GRINDVAGN
- (FIN) ALUSLEVY ULOKETELINEESEEN
- (PL) PODKŁADKA DO WÓZKA BRAMY SAMONOŚNEJ
- (SK) PODLOŽKA PRE SAMONOSNÝ NOSNÍK
- (EE) SEIB KONSŌOLALUSE JAOKS
- (LT) PŪVERŽLĖ GEMBINIŲ VARTŲ VEŽIMĖLIUI
- (LV) PĀPLĀKSNE KONSŌLES NESOŠĀJAM RUĻĻU BLOKAM

- (CZ) PODLOŽKA PRO VOZÍK
- (RO) ȘAIBĂ PENTRU SISTEMUL DE CULISARE ÎN CONSOLĂ
- (HR) PODLOŠKA ZA NOSIVO PODVOZJE
- (RUS) ШАЙБА ДЛЯ РОЛИКОВЫХ ТЕЛЕЖЕК САМОНЕСУЩИХ ВОРОТ
- (SLO) PODLOŽKA ZA VOZIČEK
- (TR) MANİVELA TAŞIYICISI İÇİN RONDELA
- (AR) حجة لنوابة الكترول
- (CHN) 悬臂架垫片
- (MAL) SESENDAL UNTUK PEMBAWA JULUR
- (H) ALÁTÉT TOLÓKAPU FUTÓKOCSIHOZ
- (IL) הקטן לנלגלם לקרמול
- (BG) ВЛОЖКА ЗА КОНЗОЛНА КОЛИЧКА
- (KO) 캔틸레버 이송대용 와셔
- (SRB) PODLOŠKA ZA SAMONOSIVU KARIJU

Art.	L	A	K	M	N	S	CARRIAGE	1pc			CODE
								kg	pcs	kg	
								mm			
DESK SK 2	189	140	25	178	25	2	SPEED SK	0,27	6	1,62	1700320
DESK SK 4	189	140	25	178	25	4	SPEED SK	0,54	6	3,24	1700321
DESK SK 6	189	140	25	178	25	6	SPEED SK	0,81	6	4,86	1700322

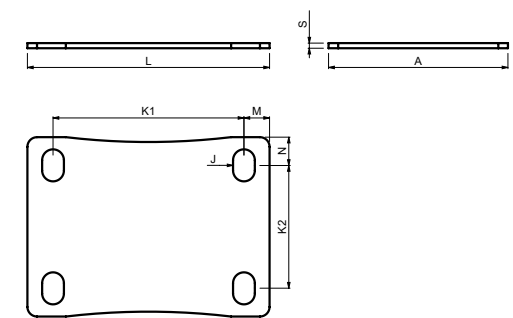

- (GB) WASHER FOR CANTILEVER CARRIAGE
- (D) UNTERLEGSCHIBE FÜR AUSLEGERSCHLITTEN
- (F) RONDELLE POUR CHARIOT CANTILEVER
- (E) TUERCA PARA CARRO EN VOLADIZO
- (P) ARRUELA PARA TRANSPORTE DE CANTILEVER
- (I) RONDELLA PER CARRELLO CANCELLO AUTOPORTANTE
- (DK) SKIVE TIL FRITBÆRENDE PORT
- (NL) RING VOOR SCHUIFWAGEN
- (N) SKIVE FOR RULLEPORTVOGN
- (S) BRICKA FÖR FRIBÄRANDE GRINDVAGN
- (FIN) ALUSLEVY ULOKETELINEESEEN
- (PL) PODKŁADKA DO WÓZKA BRAMY SAMONOŚNEJ
- (SK) PODLOŽKA PRE SAMONOSNÝ NOSNÍK
- (EE) SEIB KONSŌOLALUSE JAOKS
- (LT) PŪVERŽLĖ GEMBINIŲ VARTŲ VEŽIMĖLIUI
- (LV) PĀPLĀKSNE KONSŌLES NESOŠĀJAM RUĻĻU BLOKAM

- (CZ) PODLOŽKA PRO VOZÍK
- (RO) ȘAIBĂ PENTRU SISTEMUL DE CULISARE ÎN CONSOLĂ
- (HR) PODLOŠKA ZA NOSIVO PODVOZJE
- (RUS) ШАЙБА ДЛЯ РОЛИКОВЫХ ТЕЛЕЖЕК САМОНЕСУЩИХ ВОРОТ
- (SLO) PODLOŽKA ZA VOZIČEK
- (TR) MANİVELA TAŞIYICISI İÇİN RONDELA
- (AR) حجة لنوابة الكترول
- (CHN) 悬臂架垫片
- (MAL) SESENDAL UNTUK PEMBAWA JULUR
- (H) ALÁTÉT TOLÓKAPU FUTÓKOCSIHOZ
- (IL) הקטן לנלגלם לקרמול
- (BG) ВЛОЖКА ЗА КОНЗОЛНА КОЛИЧКА
- (KO) 캔틸레버 이송대용 와셔
- (SRB) PODLOŠKA ZA SAMONOSIVU KARIJU

Art.	L	A	J	K1	K2	M	N	S	CARRIAGE	1pc			CODE
										kg	pcs	kg	
										mm			
RAMP SE 2	189	140	17x25	149	96	20	22	2	SPEED SE	0,38	6	2,28	1700283
RAMP SE 4	189	140	17x25	149	96	20	22	4	SPEED SE	0,75	6	4,5	1700284
RAMP SE 6	189	140	17x25	149	96	20	22	6	SPEED SE	1,08	6	6,48	1700285

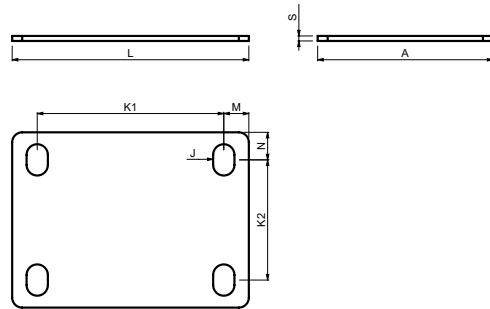

- (GB) WASHER FOR CANTILEVER CARRIAGE
- (D) UNTERLEGSCHIBE FÜR AUSLEGERSCHLITTEN
- (F) RONDELLE POUR CHARIOT CANTILEVER
- (E) TUERCA PARA CARRO EN VOLADIZO
- (P) ARRUELA PARA TRANSPORTE DE CANTILEVER
- (I) RONDELLA PER CARRELLO CANCELLO AUTOPORTANTE
- (DK) SKIVE TIL FRITBÆRENDE PORT
- (NL) RING VOOR SCHUIFWAGEN
- (N) SKIVE FOR RULLEPORTVOGN
- (S) BRICKA FÖR FRIBÄRANDE GRINDVAGN
- (FIN) ALUSLEVY ULOKETELINEESEEN
- (PL) PODKŁADKA DO WÓZKA BRAMY SAMONOŚNEJ
- (SK) PODLOŽKA PRE SAMONOSNÝ NOSNÍK
- (EE) SEIB KONSOOLALUSE JAOKS
- (LT) POVERŽLĖ GEMBINIŲ VARTŲ VEŽIMĖLIUI
- (LV) PĀPLĀKSNE KONSOLĒS NESOŠĀJAM RUĻĻU BLOKAM

- (CZ) PODLOŽKA PRO VOZÍK
- (RO) ȘAIBĂ PENTRU SISTEMUL DE CULISARE ÎN CONSOLĂ
- (HR) PODLOŠKA ZA NOSIVO PODVOZJE
- (RUS) ШАЙБА ДЛЯ РОЛИКОВЫХ ТЕЛЕЖЕК САМОНЕСУЩИХ ВОРОТ
- (SLO) PODLOŽKA ZA VOZIČEK
- (TR) MANİVELA TAŞIYICISI İÇİN RONDELA
- (AR) حلبة لولاية الكابول
- (CHN) 悬臂架垫片
- (MAL) SESENDAL UNTUK PEMBAWA JULUR
- (H) ALÁTÉT TOLÓKAPU FUTÓKOCSIHOZ
- (IL) הקטת לנגלגים קובדויל
- (BG) ВЛОЖКА ЗА КОНЗОЛНА КОЛИЧКА
- (KO) 캔틸레버 이송대용 와셔
- (SRB) PODLOŠKA ZA SAMONOSIVU KARIJU

Art.	L	A	J	K1	K2	M	N	S	CARRIAGE	1pc				CODE
											kg	pcs	kg	
mm											kg	pcs	kg	
RAMP S 2	189	140	17x25	149	96	20	22	2	SPEED S	0,4	6	2,4	1700286	
RAMP S 4	189	140	17x25	149	96	20	22	4	SPEED S	0,78	6	4,68	1700287	
RAMP S 6	189	140	17x25	149	96	20	22	6	SPEED S	1,13	6	6,78	1700288	

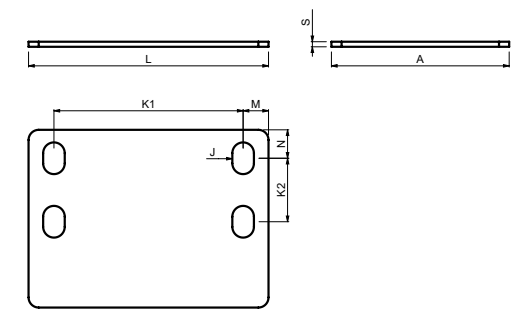

- (GB) WASHER FOR CANTILEVER CARRIAGE
- (D) UNTERLEGSCHIBE FÜR AUSLEGERSCHLITTEN
- (F) RONDELLE POUR CHARIOT CANTILEVER
- (E) TUERCA PARA CARRO EN VOLADIZO
- (P) ARRUELA PARA TRANSPORTE DE CANTILEVER
- (I) RONDELLA PER CARRELLO CANCELLO AUTOPORTANTE
- (DK) SKIVE TIL FRITBÆRENDE PORT
- (NL) RING VOOR SCHUIFWAGEN
- (N) SKIVE FOR RULLEPORTVOGN
- (S) BRICKA FÖR FRIBÄRANDE GRINDVAGN
- (FIN) ALUSLEVY ULOKETELINEESEEN
- (PL) PODKŁADKA DO WÓZKA BRAMY SAMONOŚNEJ
- (SK) PODLOŽKA PRE SAMONOSNÝ NOSNÍK
- (EE) SEIB KONSOOLALUSE JAOKS
- (LT) POVERŽLĖ GEMBINIŲ VARTŲ VEŽIMĖLIUI
- (LV) PĀPLĀKSNE KONSOLĒS NESOŠĀJAM RUĻĻU BLOKAM

- (CZ) PODLOŽKA PRO VOZÍK
- (RO) ȘAIBĂ PENTRU SISTEMUL DE CULISARE ÎN CONSOLĂ
- (HR) PODLOŠKA ZA NOSIVO PODVOZJE
- (RUS) ШАЙБА ДЛЯ РОЛИКОВЫХ ТЕЛЕЖЕК САМОНЕСУЩИХ ВОРОТ
- (SLO) PODLOŽKA ZA VOZIČEK
- (TR) MANİVELA TAŞIYICISI İÇİN RONDELA
- (AR) حلبة لولاية الكابول
- (CHN) 悬臂架垫片
- (MAL) SESENDAL UNTUK PEMBAWA JULUR
- (H) ALÁTÉT TOLÓKAPU FUTÓKOCSIHOZ
- (IL) הקטת לנגלגים קובדויל
- (BG) ВЛОЖКА ЗА КОНЗОЛНА КОЛИЧКА
- (KO) 캔틸레버 이송대용 와셔
- (SRB) PODLOŠKA ZA SAMONOSIVU KARIJU

Art.	L	A	J	K1	K2	M	N	S	CARRIAGE	1pc				CODE
											kg	pcs	kg	
mm											kg	pcs	kg	
RAMP SK 2	189	140	17x25	149	50	20	22	2	SPEED SK	0,4	6	2,4	1700289	
RAMP SK 4	189	140	17x25	149	50	20	22	4	SPEED SK	0,78	6	4,68	1700290	
RAMP SK 6	189	140	17x25	149	50	20	22	6	SPEED SK	1,13	6	6,78	1700291	

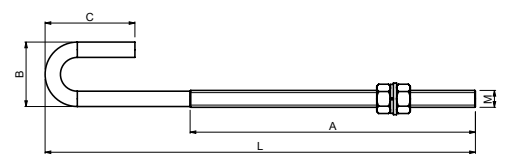

- (GB) FIXING BAR FOR CANTILEVER CARRIAGE
- (D) BEFESTIGUNGSSTANGE FÜR AUSLEGERSCHLITTEN
- (F) BARRE DE FIXATION POUR CHARIOT CANTILEVER
- (E) BARRA DE FIJACIÓN PARA CARRO EN VOLADIZO
- (P) BARRA DE FIXAÇÃO DE TRANSPORTE DE CANTILEVER
- (I) BARRA DI FISSAGGIO PER CARRELLO CANCELLO AUTOPORTANTE
- (DK) FASTGØRELSESSTANG TIL FRITBÆRENDE PORT
- (NL) BEVESTIGINGSBALK VOOR SCHUIFWAGEN
- (N) FESTESTANG FOR RULLEPORT
- (S) FÄSTBALK FÖR FRIBÄRANDE GRINDVAGN
- (FIN) KIINNITYSPALKKI ULOKETELINEESEEN
- (PL) LISTWA MOCUJĄCA DO WÓZKA BRAMY SAMONOŚNEJ
- (SK) UPEVNŔOVACIA TYČ PRE SAMONOSNÝ NOSNÍK
- (EE) FIKSEERIMISTALA KONSOLALUSE JAOKS
- (LT) TVIRTINIMO STRYPAS GEMBINIŲ VARTŲ VEŽIMĖLIUI
- (LV) FIKSĒJOŠAIS STIENIS KONSOLĒS NESOŠAJAM RUĻĻU BLOKAM

- (CZ) FIXAČNÍ TYČ PRO VOZÍK
- (RO) BARĂ DE FIXARE PENTRU SISTEMUL DE CULISARE ÎN CONSOLĂ
- (HR) FIKSIRAJUĆA ŠIPKA ZA NOSIVO PODVOZJE
- (RUS) КРЕПЕЖНЫЙ СТЕРЖЕНЬ ДЛЯ РОЛИКОВЫХ ТЕЛЕЖЕК САМОНЕСУЩИХ ВОРОТ
- (SLO) PRITRDLJNI DROG ZA VOZIČEK
- (TR) MANIVELA TAŞIYICISI İÇİN SABITLEME ÇUBUĞU
- (AR) قضيب التثبيت لواء الكابول
- (CHN) 悬臂架固定条
- (MAL) BAR IKATAN UNTUK PEMBAWA JULUR
- (H) RÖGZÍTŐRŰD TOLÓKAPU FUTÓKOCSIHOZ
- (IL) מוט קיבוע לדגלגלים ל קרונדולי
- (BG) ФИКСАТОР ЗА КОНЗОЛНА КОЛИЧКА
- (KO) 캔틸레버 이동대용 고정대
- (SRB) FIKSIRAJUĆA ŠIPKA ZA SAMONOSIVU KAPIJU

Art.	L	A	B	C	M	WASHER	1pc				CODE
								kg	pcs	kg	
CLINCH 16	410	300	60	80	M16	RAMP	0,72	12	8,64	1700239	

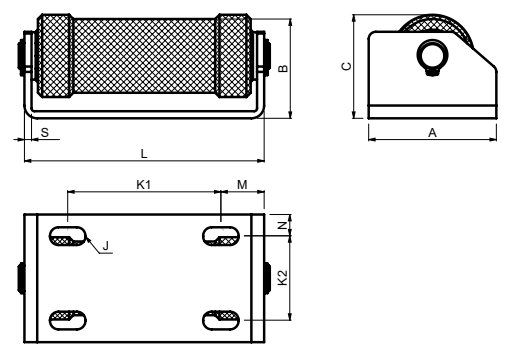

- (GB) SUPPORT ROLLER FOR CANTILEVER GATE
- (D) STÜTZROLLE FÜR AUSLEGERTOR
- (F) ROULEAU DE SUPPORT POUR PORTAIL COULISSANT AUTOPORTANT
- (E) RODILLO DE SOPORTE PARA PORTÓN EN VOLADIZO
- (P) ROLO DE SUPORTE PARA PORTÃO DE CANTILEVER
- (I) RULLO DI SOSTEGNO PER CANCELLO AUTOPORTANTE
- (DK) STØTTERULLE TIL FRITBÆRENDE PORT
- (NL) STEUNROL VOOR SCHUIFPOORT
- (N) STØTTERULLE FOR RULLEPORT
- (S) STÖDRULLE FÖR FRIBÄRANDE GRIND
- (FIN) TUKIRULLA ULOKEPORTTIIN
- (PL) ROLKA DOLNA DO BRAMY SAMONOŚNEJ
- (SK) PODPORNÝ VALEC PRE SAMONOSNÉ BRÁNY
- (EE) TUGIRULLIK KONSOLVÁRAVA JAOKS
- (LT) ATRAMINIS RITINĖLIS GEMBINIAMS VARTAMS
- (LV) BALSTA RULLĪTIS KONSOLVEIDA VĀRTIEM

- (CZ) KONZOLA S KLDKOU PRO PODPĚRU POSUVNÉ SAMONOSNÉ BRÁNY
- (RO) ROLĂ DE SUSȚINERE PENTRU POARTA ÎN CONSOLĂ
- (HR) POTPORNI VALJAK ZA NOSIVA VRATA
- (RUS) ОПОРНЫЙ РОЛИК ДЛЯ САМОНЕСУЩИХ ВОРОТ
- (SLO) PODPORNI VALJ ZA SAMONOSNA DRSNA VRATA
- (TR) MANIVELA KAPI İÇİN DESTEK MAKARASI
- (AR) اسطوانة الدعم لواء الكابول
- (CHN) 悬臂门支撑棍
- (MAL) PENGELEK SOKONGAN UNTUK GET JULUR
- (H) TARTÓGÖRGŐ TOLÓKAPUHOZ
- (IL) דגלגל תמיכה לישער קרונדולי
- (BG) ПОДДЪРЖАЩА РОЛКА ЗА КОНЗОЛНА ВРАТА
- (KO) 캔틸레버 게이트용 지지 롤러
- (SRB) NOSEČI VALJAK ZA SAMONOSIVU KAPIJU

Art.	L	A	B	C	J	K1	K2	M	N	S	1pc				CODE
												kg	pcs	kg	
DRIVESHAFT 80	144	90	70	73	13x25	107	60	31	15	5	1,37	4	5,48	1700332	
DRIVESHAFT 100	169	90	70	73	13x25	107	60	31	15	5	1,56	4	6,24	1700333	

DESIGNED FOR STRAIGHT ROLLING MOVEMENT











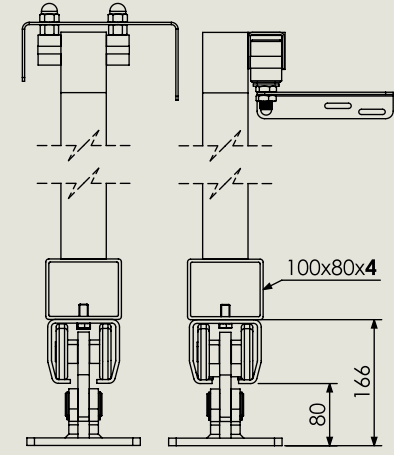











**CAIS** CANTILEVER ME 8.0

CANTILEVER HARDWARE

CANTILEVER ME									
	mm: kg	mm: kg	mm: kg	mm: kg	mm: kg	mm: kg	mm: kg	mm: kg	mm: kg
A	4000	4500	5000	5500	6000	6500	7000	7500	8000
max. weight gate	500 kg	525 kg	550 kg	575 kg	600 kg	625 kg	650 kg	675 kg	700 kg
B	1200	1350	1500	1650	1800	1950	2100	2250	2400
C	1860	2010	2160	2310	2460	2610	2760	2910	3060
D	330	330	330	330	330	330	330	330	330



-  EASY ASSEMBLING
-  FAST NO WELDING
-  15 BOLTS  
15 RIVET NUTS INCLUDED (\*)
-  «C» TRACK SERIAL NO. 100% COMPATIBILITY CARRIAGE TESTED
-  GERMAN STEEL WUPPERMANN
-  270 g/m<sup>2</sup> HOT DIPPED GALVANIZED
-  ARROW STRAIGHT «C» TRACK
-  BUILD IN FLYING HOLE PUNCH - EVERY 400 mm
-  GALVANIZED INTERNAL EDGES
-  MADE IN CZECH REPUBLIC
-  C 2 HQ BEARINGS
-  CARRIAGES CENTER HOLES MILLED NOT LASERED
-  MULTI RIVITED SECTIONS
-  JAPANESE ROBOTICS FANUC
-  UNIVERSITY OF TECHNOLOGY - BRNO
-  - 37°C TESTED & PROVEN
-  + 50°C TESTED & PROVEN
-  NO WELDING NEEDED

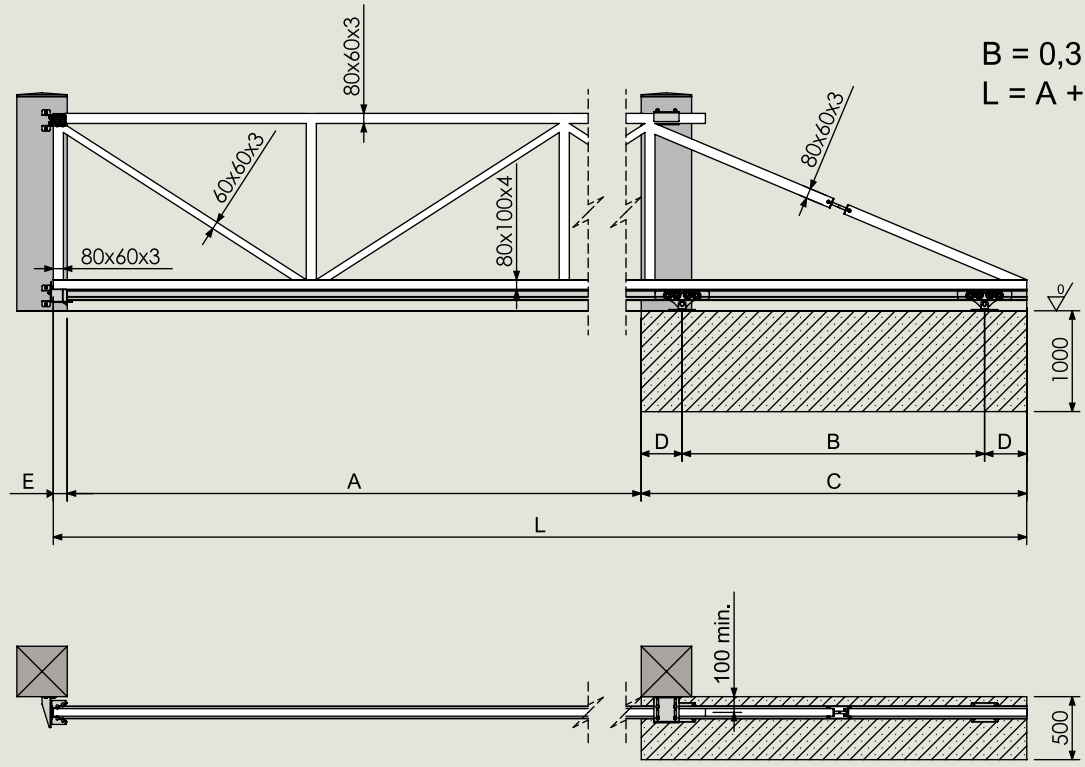

$$B = 0,3 \times A$$

$$L = A + B + (2 \times D) + E$$

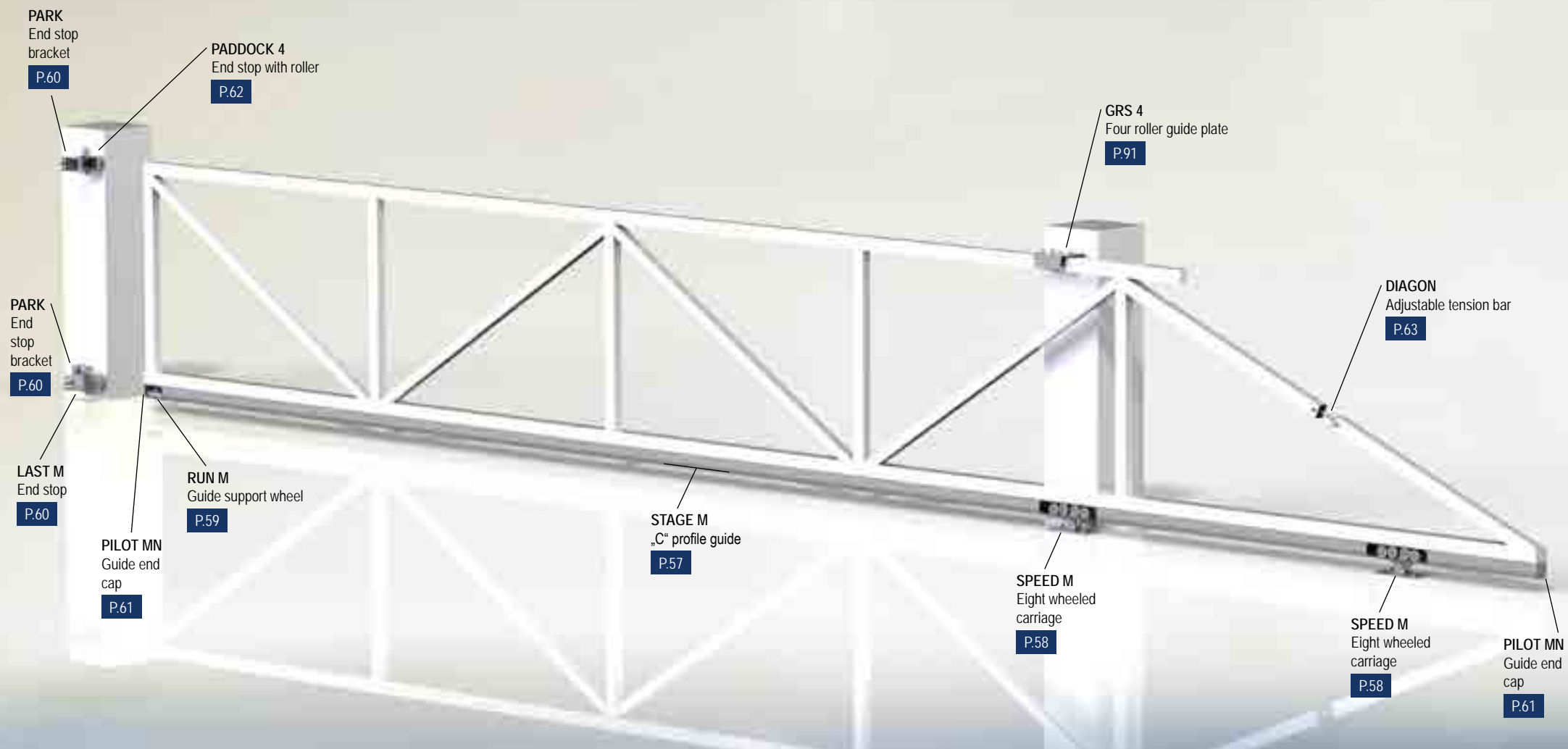







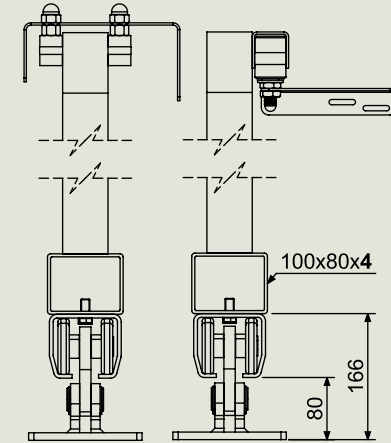











 **CANTILEVER M 8.0**

CANTILEVER HARDWARE

CANTILEVER M									
	mm: kg	mm: kg	mm: kg	mm: kg	mm: kg	mm: kg	mm: kg	mm: kg	mm: kg
A	4000	4500	5000	5500	6000	6500	7000	7500	8000
max. weight gate	500 kg	525 kg	550 kg	575 kg	600 kg	625 kg	650 kg	675 kg	700 kg
B	1200	1350	1500	1650	1800	1950	2100	2250	2400
C	1860	2010	2160	2310	2460	2610	2760	2910	3060
D	330	330	330	330	330	330	330	330	330



-  EASY ASSEMBLING
-  FAST NO WELDING
-  15 BOLTS  
15 RIVET NUTS INCLUDED (\*)
-  «C» TRACK SERIAL NO.  
100% COMPATIBILITY  
CARRIAGE TESTED
-  GERMAN STEEL  
WUPPERMANN
-  270  
g/m<sup>2</sup> HOT DIPPED  
GALVANIZED
-  ARROW STRAIGHT  
«C» TRACK
-  BUILD IN FLYING HOLE  
PUNCH - EVERY 400 mm
-  GALVANIZED  
INTERNAL EDGES
-  MADE IN  
CZECH REPUBLIC
-  C 2  
HQ BEARINGS
-  CARRIAGES CENTER  
HOLES MILLED  
NOT LASERED
-  MULTI RIVETED  
SECTIONS
-  JPN JAPANESE ROBOTICS  
FANUC
-  R&D UNIVERSITY OF  
TECHNOLOGY - BRNO
-  - 37°C  
TESTED & PROVEN
-  + 50°C  
TESTED & PROVEN
-  NO WELDING  
NEEDED

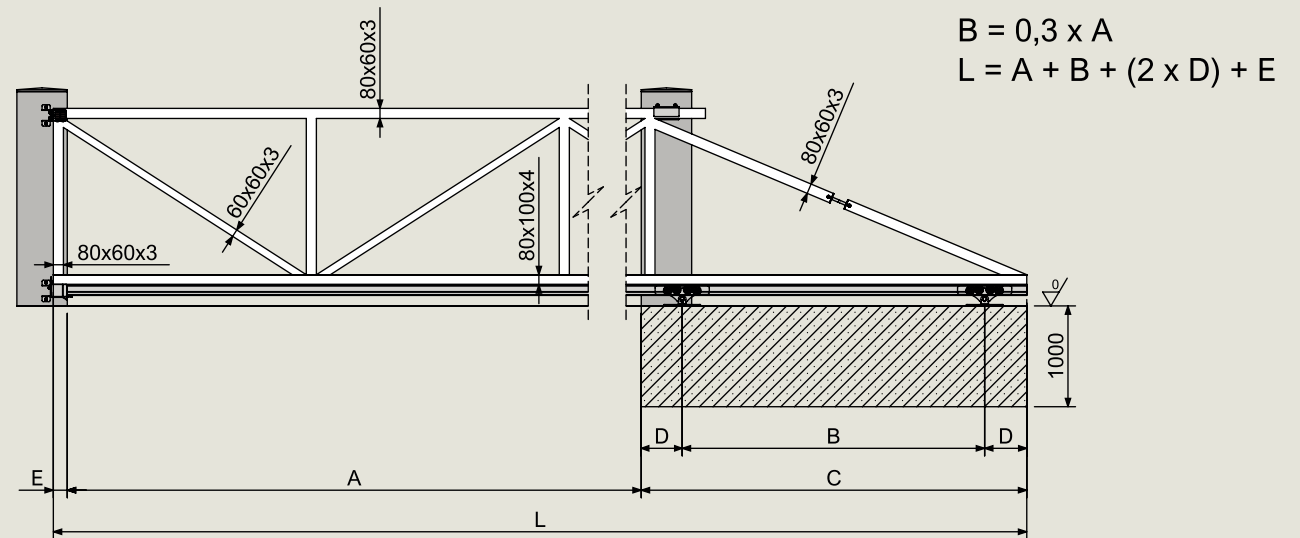

(\*) ONLY SETS

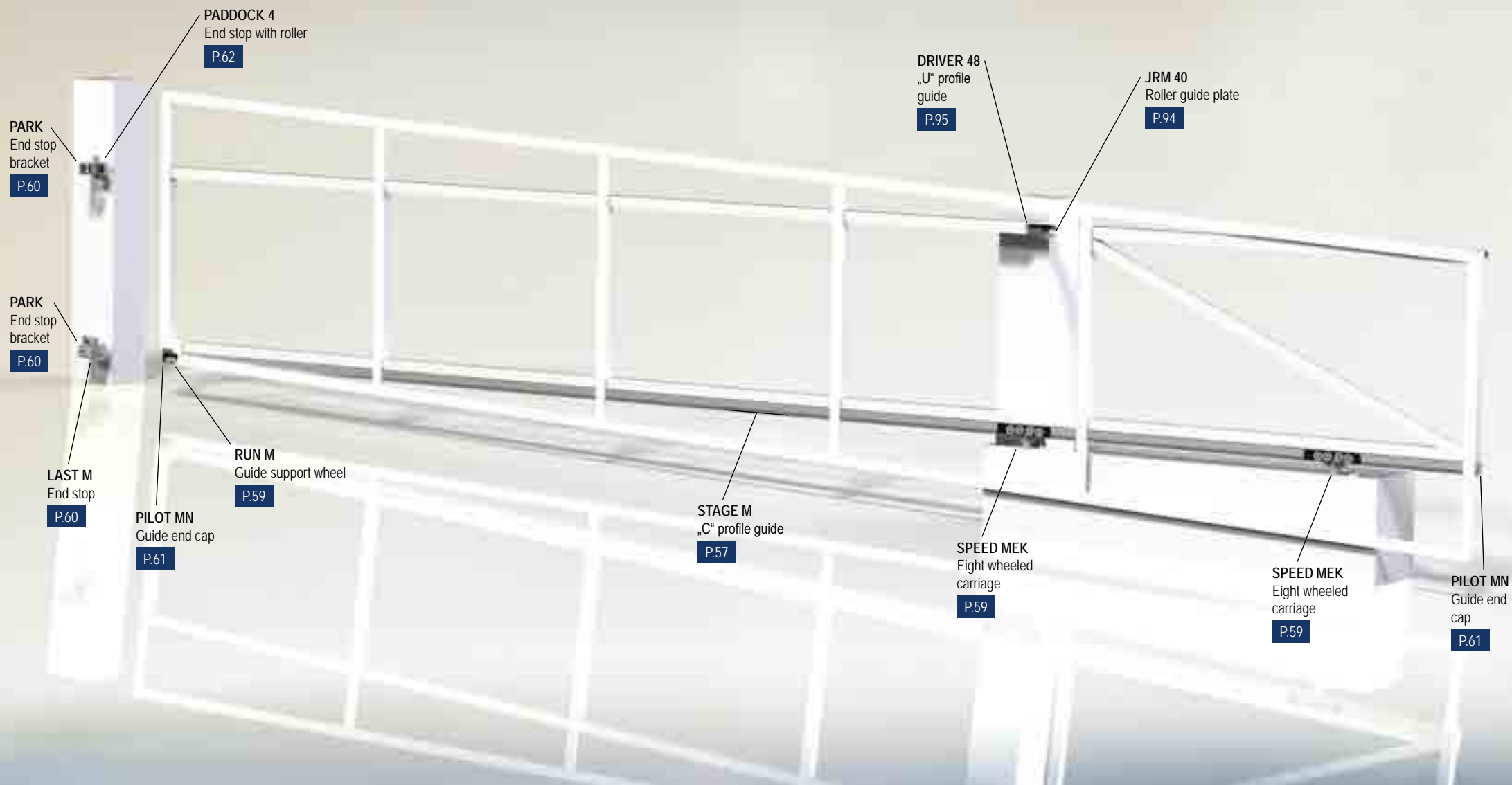

# CAIS CANTILEVER MEK 8.0

CANTILEVER HARDWARE

CANTILEVER MEK									
	mm: kg	mm: kg	mm: kg	mm: kg	mm: kg	mm: kg	mm: kg	mm: kg	mm: kg
A	4000	4500	5000	5500	6000	6500	7000	7500	8000
max. weight gate	500 kg	525 kg	550 kg	575 kg	600 kg	625 kg	650 kg	675 kg	700 kg
B	1200	1350	1500	1650	1800	1950	2100	2250	2400
C	1860	2010	2160	2310	2460	2610	2760	2910	3060
D	330	330	330	330	330	330	330	330	330

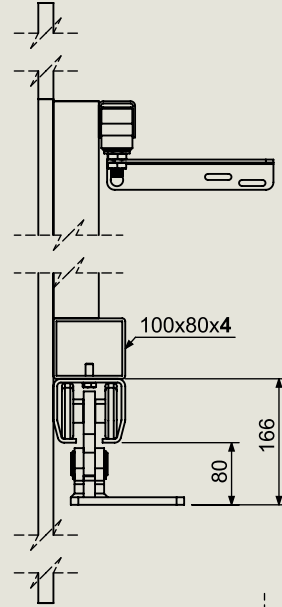





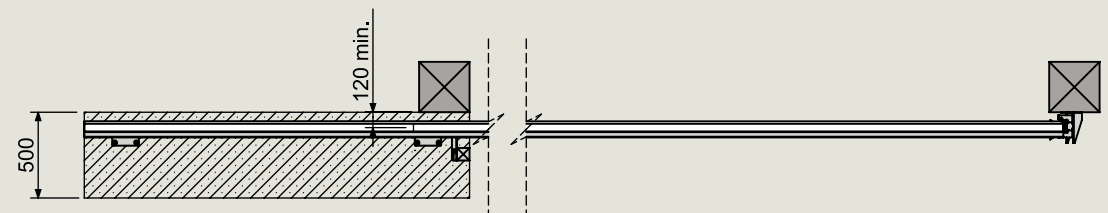
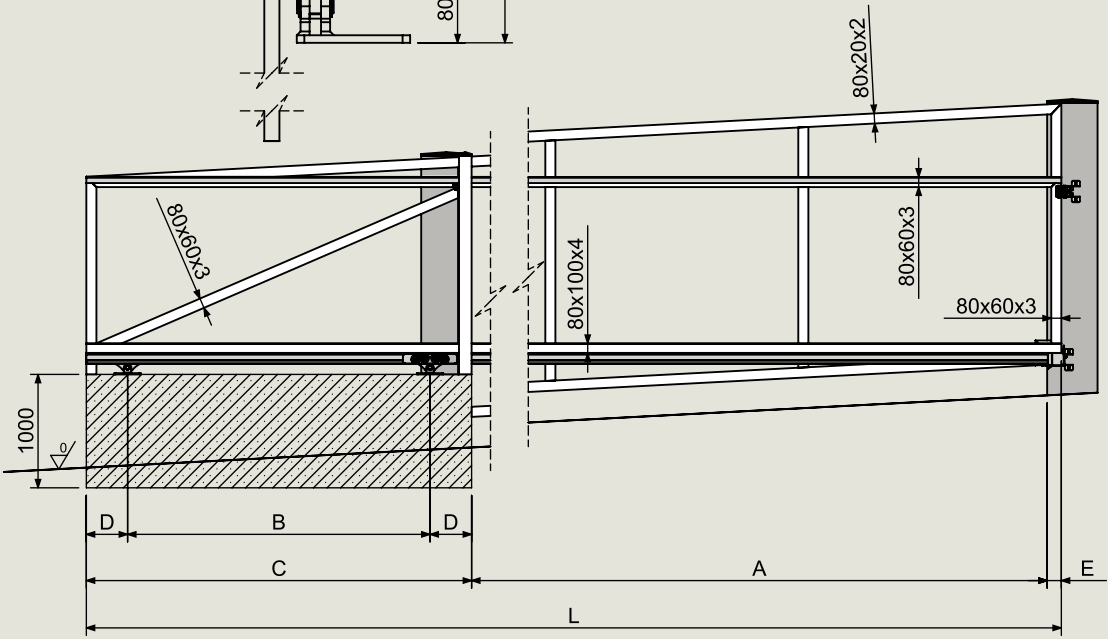















$$B = 0,3 \times A$$

$$L = A + B + (2 \times D) + E$$



(\*) ONLY SETS

-  SUITABLE FOR INCLINED SURFACE INSTALLATION
-  EASY ASSEMBLING
-  FAST NO WELDING
-  15 BOLTS  
15 RIVET NUTS INCLUDED (\*)
-  «C» TRACK SERIAL NO. 100% COMPATIBILITY CARRIAGE TESTED
-  GERMAN STEEL WUPPERMANN
-  270 g/m<sup>2</sup> HOT DIPPED GALVANIZED
-  ARROW STRAIGHT «C» TRACK
-  BUILD IN FLYING HOLE PUNCH - EVERY 400 mm
-  GALVANIZED INTERNAL EDGES
-  ASYMMETRIC EIGHT WHEELED CARRIAGE
-  C 2 HQ BEARINGS
-  CARRIAGES CENTER HOLES MILLED NOT LASERED
-  MULTI RIVITED SECTIONS
-  JPN JAPANESE ROBOTICS FANUC
-  R&D UNIVERSITY OF TECHNOLOGY - BRNO
-  - 37°C TESTED & PROVEN
-  + 50°C TESTED & PROVEN
-  CZ MADE IN CZECH REPUBLIC
-  NO WELDING NEEDED

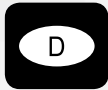

**W Wuppermann**  
GERMAN STEEL

GALVANIZED  
INTERNAL  
EDGES



**270**  
g/m<sup>2</sup>

HOT  
DIPPED  
GALVANIZED

SPECIAL  
THICKNESS

**5,00**  
mm



- 37°C  
TESTED  
& PROVEN



+ 50°C  
TESTED  
& PROVEN



**24**  
months

24 MONTHS  
TESTED  
& PROVEN



MADE IN  
CZECH  
REPUBLIC



15 BOLTS  
15 RIVET NUTS  
INCLUDED (\*)



BUILD IN  
FLYING HOLE PUNCH  
EVERY 400 mm



SERIAL NUMBER  
CARRIAGE COMPATIBILITY  
TESTED & PROVEN



EASY  
ASSEMBLING



FAST  
NO WELDING



AVAILABLE  
CUSTOMISED LENGTHS  
UNDER SPECIAL TERMS



ARROW  
STRAIGHT  
«C» TRACK



EIGHTEEN ROLL FORMERS  
THE MOST IN THE INDUSTRY  
REMOVE THE INSET «MEMORY» OF STEEL



SLOW ROLLING  
NO HEAT DURING THE PRODUCTION  
KEEPING THE MATERIAL WHERE IT IS ROLLED



BRNO  
UNIVERSITY  
OF TECHNOLOGY

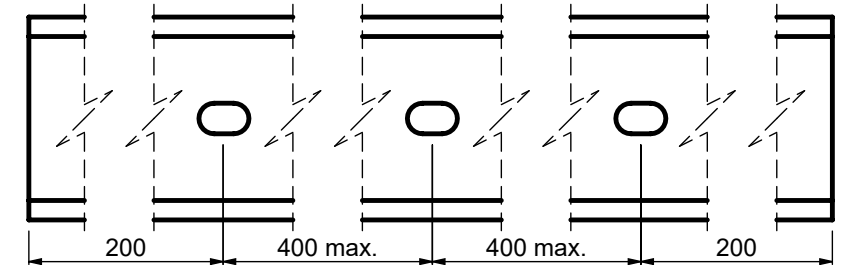
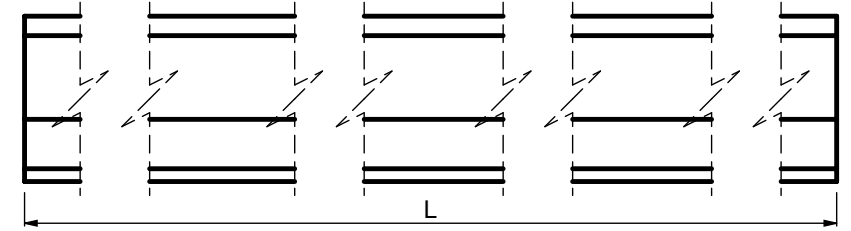
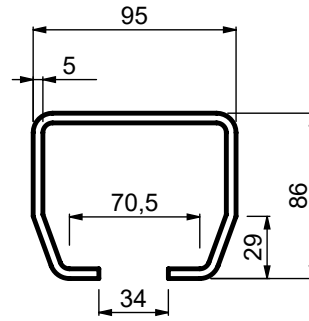
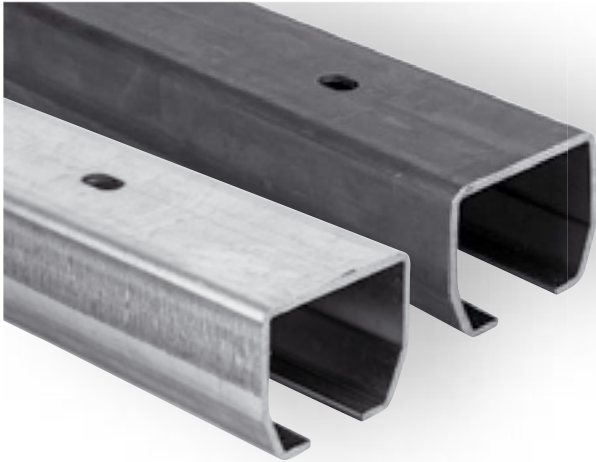





- (GB) „C” PROFILE GUIDE FOR CANTILEVER GATE
- (D) „C” PROFIL FÜR FREITRAGENDE SCHIEBETÖRE
- (F) GUIDE À PROFIL EN « C » POUR PORTAIL AUTOPORTANT
- (E) GUÍA CON PERFIL “C” PARA PUERTA VOLADIZA
- (P) GUIA DE PERFIL “C” PARA PORTÃO CANTILEVER
- (I) GUIDA CON PROFILO A “C” PER CANCELLO AUTOPORTANTE
- (DK) “C” PROFILVANGE TIL FRITBÆRENDE PORT
- (NL) “C” PROFIEL GELEIDER VOOR VRIJDRAGENDE SCHUIFPOOR
- (N) “C”-PROFILSKINNE FOR FRITTBÆRENDE PORTX
- (S) “C” GEJDPROFIL FÖR FRIBÅRANDE GRIND
- (FIN) “C”-PROFILLIÖHJAIN ULÖKEKANNETEISEEN PORTTIIN
- (PL) SZYNA DO BRAM SAMONOŚNYCH
- (SK) NOSNÝ „C” PROFIL PRE POSUVNÚ SAMONOSNÚ BRÁNU
- (EE) “C”-PROFII LI JUHIK KONSOLVÄRAVA JAOKS
- (LT) „C” FORMOS PROFILI UOŲAS KREIPTUVAS GEMBINIAMS VARTAMS
- (LV) “C” VEIDA PROFILS KONSOLVEIDA VÄRTIEM

- (CZ) ŠÍNA „C” PROFIL PRO POSUVNOU SAMONOSNOU BRÁNU
- (RO) GHIDAJ CU PROFIL „C” PENTRU POARTA AUTOPORTANTĂ ÎN CONSOLĂ
- (HR) VODILICA „C” PROFILA ZA KLIZNA DVORIŠNA VRATA
- (RU) НАПРАВЛЯЮЩИЙ РЕЛЬС / ПРОФИЛЬ «С» ДЛЯ ОТКАТНЫХ САМОНЕСУЩИХ ВОРОТ
- (SLO) “C” VODILO ZA SAMONOSNA DRSNA VRATA
- (TR) KONSOL BAĞÇE KAPISI İÇİN “C” PROFİL KIZAĞI
- (AR) للبوابة المدعومة “C” دعامة الجذبة الحلقية
- (CHN) 悬臂门“C”型导轨
- (MAL) PANDU PROFIL “C” UNTUK PINTU PAGAR JULUR
- (H) C-VEZETŐSÍN TOLÓKAPUHOZ
- (IL) קורה בפירופיל “C” לשער קונסולי
- (BG) “C”-ОБРАЗНА РЕЛСА ЗА КОНЗОЛНА ВРАТА
- (KO) 캔틸레버 게이트용 “C”자형 프로필 가이드
- (SRB) VODICA „C” PROFILA ZA SAMONOSIVU KAPIJU

Art.	CARRIAGE	SURFACE FINISH	L/1pc	1pc			CODE
			mm	kg	pcs	kg	
STAGE MB 6	SPEED M/ME/MEK	UNGALVANIZED	6000	65,4	12	784,8	1700011
STAGE MB 4	SPEED M/ME/MEK	UNGALVANIZED	4000	43,6	12	523,2	1700213
STAGE MB 3	SPEED M/ME/MEK	UNGALVANIZED	3000	32,7	12	392,4	1700169
STAGE MB 2	SPEED M/ME/MEK	UNGALVANIZED	2000	21,8	12	261,6	1700214
STAGE MB 1	SPEED M/ME/MEK	UNGALVANIZED	1000	10,9	12	130,8	1720026
STAGE MZ 6	SPEED M/ME/MEK	GALVANIZED	6000	65,4	12	784,8	1700012
STAGE MZ 4	SPEED M/ME/MEK	GALVANIZED	4000	43,6	12	523,2	1700215
STAGE MZ 3	SPEED M/ME/MEK	GALVANIZED	3000	32,7	12	392,4	1700170
STAGE MZ 2	SPEED M/ME/MEK	GALVANIZED	2000	21,8	12	261,6	1700216
STAGE MZ 1	SPEED M/ME/MEK	GALVANIZED	1000	10,9	12	130,8	1720036





-  C 2  
HQ BEARINGS
-  CARRIAGES CENTER  
HOLES MILLED  
NOT LASERED
-  MULTI RIVTED  
SECTIONS
-  **mono  
block** MONO BLOCK  
EIGHT WHEELED  
CARRIAGE

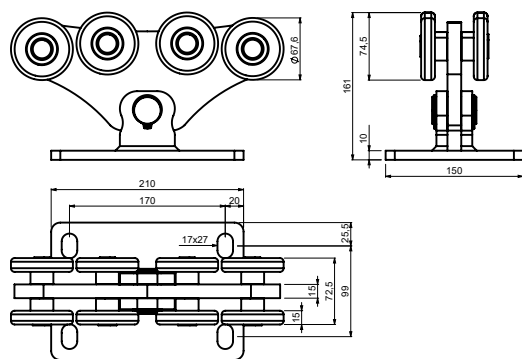





- (GB) EIGHT WHEELED CARRIAGE FOR CANTILEVER GATE
- (D) ROLLAPPARAT MIT ACHT ROLLEN FÜR FREITRAGENDE SCHIEBETORE
- (F) CHARIOT À HUIT ROUES POUR PORTAIL AUTOPORTANT
- (E) CARRIL DE OCHO RUEDAS PARA PUERTA VOLADIZA
- (P) CORREDIÇA DE OITO ROLDANAS PARA PORTÃO CANTILEVER
- (I) CARRELLO A OTTO RUOTE PER CANCELLO AUTOPORTANTE
- (DK) OTTE TRANSPORTHJUL TIL FRITTBÆRENDE PORT
- (NL) ACHTVOUDIG WIELENBLOK VOOR VRIJDRAGENDE SCHUIFPOORT
- (N) ÅTTEHJULS DRIVSKINNE TIL FRITTBÆRENDE PORT
- (S) ÅTTAHJULIG VAGN FÖR FRIBÄRANDE GRIND
- (FIN) KAHDEKSAN PYÖRÄN ALUSTA ULOKEKANNETTEISEEN PORTTIIN
- (PL) WÓZEK 8-ROLKOWY DO BRAM SAMONOŚNYCH
- (SK) VOZÍK OSEM KOLIEČKOVÝ PRE POSUVNÚ SAMONOSNÚ BRÁNU
- (EE) KAHEKSARATTALINE SUPORT KONSOOLVÁRAVA JAOKS
- (LT) VEŽIMĖLIS GEMBINIAMS VARTAMS SU AŠTUONIAIS RATUKAIS
- (LV) ASTOŅU RUĻĻU BLOKS KONSOLVEIDA VĀRTIEM

- (CZ) VOZÍK OSMIKOLOVÝ PRO POSUVNOU SAMONOSNOU BRÁNU
- (RO) CĂRUCIOR PE OPT ROȚI PENTRU POARTA AUTOPORTANTĂ ÎN CONSOLĂ
- (HR) NOSAČ S OSAM KOTAČA ZA KLIZNA DVORIŠNA VRATA
- (RUS) ВОСЬМИКОЛЕСНАЯ РОЛИКОВАЯ ТЕЛЕЖКА ДЛЯ ОТКАТНЫХ САМОНЕСУЩИХ ВОРОТ
- (SLO) VOZIČEK Z OSMIMI KOLESI ZA SAMONOSNA DRSNA VRATA
- (TR) KONSOL BAHÇE KAPISI İÇİN SEKİZ TEKERLEKLİ TAŞIYICI
- (AR) عربة مزودة بشعبي عجلات للوابت الدفعة
- (CHN) 悬臂门八轮滑架
- (MAL) PENYORONG LAPAN RODA UNTUK PINTU PAGAR JULUR
- (H) NYOLCGÖRGÖS FUTÓKOCSI TOLÓKAPUHOZ
- (IL) קרונית שמנונה גלגלים לשער קונדולי
- (BG) КОЛИЧКА С ОСЕМ РОЛКИ ЗА КОНЗОЛНА ВРАТА
- (KO) 8개 휠이 있는 캔틸레버 게이트용 이송대
- (SRB) NOSAČ SA OSAM TOČKIČA ZA SAMONOSIVU KAPIJU

Art.	A max. mm	GUIDE	1pc		CODE
			kg	pcs kg	
SPEED ME	8000	STAGE MB/MZ	9	2 18	1700009



-  C 2  
HQ BEARINGS
-  CARRIAGES CENTER  
HOLES MILLED  
NOT LASERED
-  MULTI RIVTED  
SECTIONS
-  **mono  
block** MONO BLOCK  
EIGHT WHEELED  
CARRIAGE

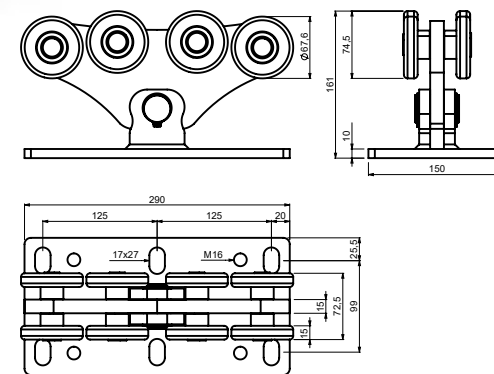





- (GB) EIGHT WHEELED CARRIAGE FOR CANTILEVER GATE
- (D) ROLLAPPARAT MIT ACHT ROLLEN FÜR FREITRAGENDE SCHIEBETORE
- (F) CHARIOT À HUIT ROUES POUR PORTAIL AUTOPORTANT
- (E) CARRIL DE OCHO RUEDAS PARA PUERTA VOLADIZA
- (P) CORREDIÇA DE OITO ROLDANAS PARA PORTÃO CANTILEVER
- (I) CARRELLO A OTTO RUOTE PER CANCELLO AUTOPORTANTE
- (DK) OTTE TRANSPORTHJUL TIL FRITTBÆRENDE PORT
- (NL) ACHTVOUDIG WIELENBLOK VOOR VRIJDRAGENDE SCHUIFPOORT
- (N) ÅTTEHJULS DRIVSKINNE TIL FRITTBÆRENDE PORT
- (S) ÅTTAHJULIG VAGN FÖR FRIBÄRANDE GRIND
- (FIN) KAHDEKSAN PYÖRÄN ALUSTA ULOKEKANNETTEISEEN PORTTIIN
- (PL) WÓZEK 8-ROLKOWY DO BRAM SAMONOŚNYCH
- (SK) VOZÍK OSEM KOLIEČKOVÝ PRE POSUVNÚ SAMONOSNÚ BRÁNU
- (EE) KAHEKSARATTALINE SUPORT KONSOOLVÁRAVA JAOKS
- (LT) VEŽIMĖLIS GEMBINIAMS VARTAMS SU AŠTUONIAIS RATUKAIS
- (LV) ASTOŅU RUĻĻU BLOKS KONSOLVEIDA VĀRTIEM

- (CZ) VOZÍK OSMIKOLOVÝ PRO POSUVNOU SAMONOSNOU BRÁNU
- (RO) CĂRUCIOR PE OPT ROȚI PENTRU POARTA AUTOPORTANTĂ ÎN CONSOLĂ
- (HR) NOSAČ S OSAM KOTAČA ZA KLIZNA DVORIŠNA VRATA
- (RUS) ВОСЬМИКОЛЕСНАЯ РОЛИКОВАЯ ТЕЛЕЖКА ДЛЯ ОТКАТНЫХ САМОНЕСУЩИХ ВОРОТ
- (SLO) VOZIČEK Z OSMIMI KOLESI ZA SAMONOSNA DRSNA VRATA
- (TR) KONSOL BAHÇE KAPISI İÇİN SEKİZ TEKERLEKLİ TAŞIYICI
- (AR) عربة مزودة بشعبي عجلات للوابت الدفعة
- (CHN) 悬臂门八轮滑架
- (MAL) PENYORONG LAPAN RODA UNTUK PINTU PAGAR JULUR
- (H) NYOLCGÖRGÖS FUTÓKOCSI TOLÓKAPUHOZ
- (IL) קרונית שמנונה גלגלים לשער קונדולי
- (BG) КОЛИЧКА С ОСЕМ РОЛКИ ЗА КОНЗОЛНА ВРАТА
- (KO) 8개 휠이 있는 캔틸레버 게이트용 이송대
- (SRB) NOSAČ SA OSAM TOČKIČA ZA SAMONOSIVU KAPIJU

Art.	A max. mm	GUIDE	1pc		CODE
			kg	pcs kg	
SPEED M	8000	STAGE MB/MZ	9,9	2 19,8	1700010



-  SUITABLE FOR INCLINED SURFACE INSTALLATION
-  ASYMMETRIC EIGHT WHEELED CARRIAGE
-  C 2 HQ BEARINGS
- mono block** MONO BLOCK EIGHT WHEELED CARRIAGE
-  CARRIAGES CENTER HOLES MILLED NOT LASERED
-  MULTI RIBBED SECTIONS

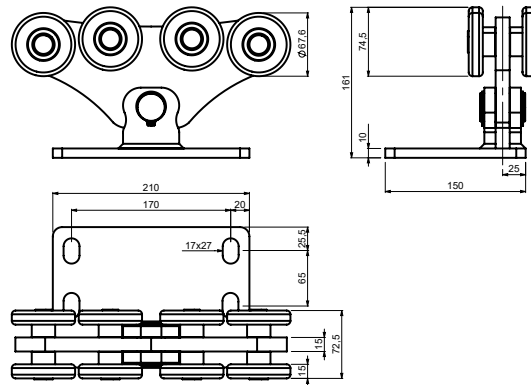

- (GB) EIGHT WHEELED CARRIAGE FOR CANTILEVER GATE
- (D) ROLLAPPARAT MIT ACHT ROLLEN FÜR FREITRAGENDE SCHIEBETORE
- (F) CHARIOT À HUIT ROUES POUR PORTAIL AUTOPORTANT
- (E) CARRIL DE OCHO RUEDAS PARA PUERTA VOLADIZA
- (P) CORREDIÇA DE OITO ROLDANAS PARA PORTÃO CANTILEVER
- (I) CARRELLO A OTTO RUOTE PER CANCELLO AUTOPORTANTE
- (DK) OTTE TRANSPORTHJUL TIL FRITTBÆRENDE PORT
- (NL) ACHTVOUDIG WIELENBLOK VOOR VRIJDRAGENDE SCHUIFPOORT
- (N) ÅTTA HJULS DRIVSKINNE TIL FRITTBÆRENDE PORT
- (S) ÅTTA HJULIG VAGN FÖR FRIBÄRANDE GRIND
- (FIN) KAHEKSAAN PYÖRÄN ALUSTA ULOKEKANNETIESEEN PORTTIIN
- (PL) WÓZEK 8-ROLKOWY DO BRAM SAMONOŚNYCH
- (SK) VOZÍK OSEM KOLIEČKOVÝ PRE POSUVNÚ SAMONOSNÚ BRÁNU
- (EE) KAHEKSARATTALINE SUPOORT KONSOLVÄRAVA JAOKS
- (LT) VEŽIMĖLIS GEMBINIAMS VARTAMS SU AŠTUONIAMS RATUKAIS
- (LV) ASTOŅU RUĻĻU BLOKS KONSOLVEIDA VĀRTIEM

- (CZ) VOZÍK OSMIKOLOVÝ PRO POSUVNOU SAMONOSNOU BRÁNU
- (RO) CĂRUCIOR PE OPT ROȚI PENTRU POARTA AUTOPORTANTĂ ÎN CONSOLĂ
- (HR) NOSAČ S OSAM KOTAČA ZA KLIZNA DVORIŠNA VRATA
- (RUS) ВОСЬМИКОЛЕСНАЯ РОЛИКОВАЯ ТЕЛЕЖКА ДЛЯ ОТКАТНЫХ САМОНЕСУЩИХ ВОРОТ
- (SLO) VOZIČEK Z OSMIMI KOLESI ZA SAMONOSNA DRSNA VRATA
- (TR) KONSOL BAHÇE KAPISI İÇİN SEKİZ TEKERLEKLİ TAŞIYICI
- (AR) عربة مزودة بشاسي عدلات للوابر الددعة
- (CHN) 悬臂门八轮滑架
- (MAL) PENYORONG LAPAN RODA UNTUK PINTU PAGAR JULUR
- (H) NYOLCGÖRGÖS FUTÓKOCSI TOLÓKAPUHOZ
- (IL) קרונית שמנונה גלגלים לשער קנדולי
- (BG) КОЛИЧКА С ОСЕМ РОЛКИ ЗА КОНЗОЛНА ВРАТА
- (KO) 8개 휠이 있는 캔틸레버 게이트용 이송대
- (SRB) NOSAČ SA OSAM TOČKIĆA ZA SAMONOSIVU KAPIJU

Art.	A	GUIDE	1pc			CODE
			kg	pcs	kg	
SPEED MEK	8000	STAGE MB/MZ	9	2	18	1700190

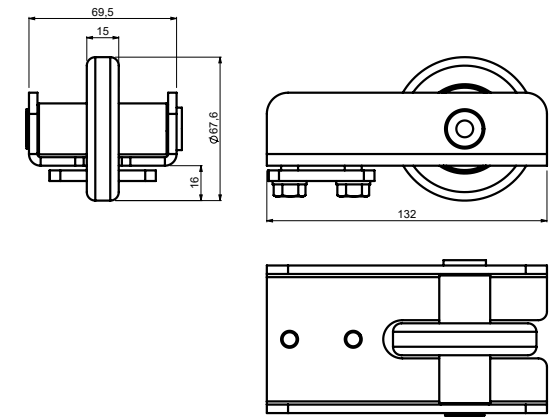

- (GB) GUIDE SUPPORT WHEEL FOR CANTILEVER GATE
- (D) STÜTZRAD FÜR FREITRAGENDE SCHIEBETORE
- (F) ROUE DE SUPPORT DE GUIDE POUR PORTAIL AUTOPORTANT
- (E) RUEDA CON SOPORTE DE GUÍA PARA PUERTA VOLADIZA
- (P) ROLDANA DE SUPORTE GUIA PARA PORTÃO CANTILEVER
- (I) RUOTA DI SOSTEGNO DELLA GUIDA PER CANCELLO AUTOPORTANTE
- (DK) VANGESTØTTEHJUL TIL FRITTBÆRENDE PORT
- (NL) DRAAGWIEL VOOR GELEIDING VRIJDRAGENDE SCHUIFPOOR
- (N) STYRESKINNE FOR STØTTEHJUL TIL FRITTBÆRENDE PORT
- (S) STÖDHJUL FÖR FRIBÄRANDE GRIND
- (FIN) OHJAIMEN TUKIPYÖRÄ ULOKEKANNETIESEEN PORTTIIN
- (PL) ROLKA NAJAZDOWA DO BRAM SAMONOŚNYCH
- (SK) NÁBEH S KLADKOU PRE POSUVNÚ SAMONOSNÚ BRÁNU
- (EE) JUHI TUGIRATAS KONSOLVÄRAVA JAOKS
- (LT) KREIPTUVO ATRAMOS RATUKAS GEMBINIAMS VARTAMS
- (LV) VADOTNES BALSTA RULLĪTIS KONSOLVEIDA VĀRTIEM

- (CZ) NÁBEH S KLADKOU PRO POSUVNOU SAMONOSNOU BRÁNU
- (RO) ROATĂ DE SUSȚINERE GHIDAJ PENTRU POARTA AUTOPORTANTĂ ÎN CONSOLĂ
- (HR) NOSIVI KOTAČ VODILICE ZA KLIZNA DVORIŠNA VRATA
- (RUS) КОНЦЕВОЙ РОЛИК ДЛЯ ОТКАТНЫХ САМОНЕСУЩИХ ВОРОТ
- (SLO) PODPORNO KOLO VODILA ZA SAMONOSNA DRSNA VRATA
- (TR) KONSOL BAHÇE KAPISI İÇİN KIZAK DESTEK TEKERLEĞİ
- (AR) عجلة دعمة نظيلية للوابر الددعة
- (CHN) 悬臂门导轨支轮
- (MAL) RODA SOKONGAN PANDU UNTUK PINTU PAGAR JULUR
- (H) VEZETŐ, MEGTÁMASZTÓ GÖRGŐ TOLÓKAPUHOZ
- (IL) גלגל תומך לשער קנדולי
- (BG) РОЛКА ЗА РЕЛСА ЗА КОНЗОЛНА ВРАТА
- (KO) 캔틸레버 게이트용 가이드 지지 휠
- (SRB) NOSEĆI TOČKIĆI VODICE ZA SAMONOSIVU KAPIJU

Art.	GUIDE	1pc			CODE
		kg	pcs	kg	
RUN M	STAGE MB/MZ	1,11	10	11,1	1700013

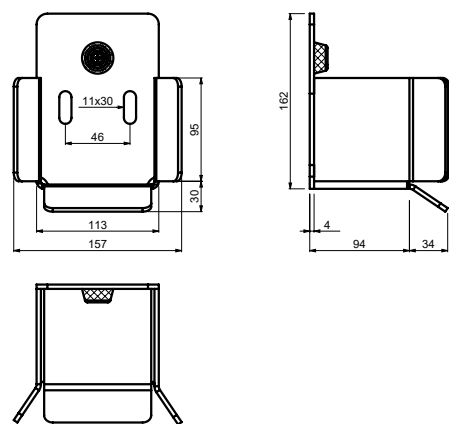

- (GB) END STOP FOR CANTILEVER GATE
- (D) EINLAUFSCHUH FÜR FREITRAGENDE SCHIEBETORE
- (F) BUTÉE POUR PORTAIL AUTOPORTANT
- (E) TOPE FINAL PARA PUERTA VOLADIZA
- (P) BATENTE PARA PORTÃO CANTILEVER
- (I) FERMO DI FINE CORSA PER CANCELLO AUTOPORTANTE
- (DK) ENDESTOP TIL FRITTBÆRENDE PORT
- (NL) EINDSTOP VOOR VRIJDRAGENDE SCHUIFPOORT
- (N) ENDESTOPPER FOR FRITTBÆRENDE PORT
- (S) ÄNDSTOPP FÖR FRIBÄRENDE GRIND
- (FIN) PÄÄTYPYSÄYTIN ULOKEKANNETIEISEEN PORTTIIN
- (PL) ODBOJNIK DO BRAM SAMONOŚNYCH
- (SK) DOJAZDOVÁ KAPSA SPODNÁ PRE POSUVNÚ SAMONOSNÚ BRÁNU
- (EE) OTSALÕPP KONSOLVÄRAVA JAOKS
- (LT) GALINIS RIBOKLIS GEMBINIAMS VARTAMS
- (LV) GALA AIZTURIS KONSOLVEIDA VÄRTIEMS

- (CZ) DOJAZDOVÁ KAPSA SPODNÍ PRO POSUVNOU SAMONOSNOU BRÁNU
- (RO) OPRITOR CURSĂ PENTRU POARTA AUTOPORTANTĂ ÎN CONSOLĂ
- (HR) GRANIČNIK ZA KLIZNA DVORIŠNA VRATA
- (RUS) УПЛАВЛИВАТЕЛЬ НИЖНИЙ ДЛЯ ОТКАТНЫХ САМОНЕСУЩИХ ВОРОТ
- (SLO) ZAUSTAVLJALNIK ZA SAMONOSNA DRŠNA VRATA
- (TR) KONSOL BAŇÇE KAPISI İÇİN UÇ TESPİT PARÇASI
- (AR) المقاعد الطرفية للوابية المدعومة
- (CHN) 悬臂门终点挡块
- (MAL) PENYENDAL Hujung Untuk Pintu Pagar Julur
- (H) ÜTKÖZŐ TOLÓKARUHOZ
- (IL) מקביל קצה לשער קנדולי
- (BG) СТОПЕР ЗА КОНЗОЛНА ВРАТА
- (KO) 캔틸레버 게이트용 종단 장치대
- (SRB) GRANIČNIK ZA SAMONOSIVU KAPIJU

Art.	GUIDE	1pc			CODE
		kg	pcs	kg	
LAST M	STAGE MB/MZ	1,96	2	3,92	1700014

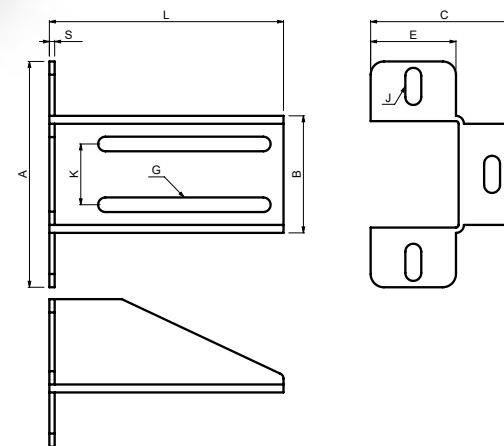

- (GB) END STOP BRACKET
- (D) KONSOLE FÜR EINLAUFSCHUH
- (F) ÉTRIER POUR BUTÉE
- (E) SOPORTE DE TOPE FINAL
- (P) SUPORTE DE BATENTE
- (I) STAFFA PER FERMO DI FINE CORSA
- (DK) ENDESTOP BESLAG
- (NL) EINDSTOP BEVESTIGINGSBEUGEL
- (N) STOPPEBRACKET
- (S) ÄNDSTOPP KONSOL
- (FIN) PÄÄTYPYSÄYTTIMEN KANNATIN
- (PL) WSPORNIK ODBOJNIKA
- (SK) KONZOLA PRE DOJAZDOVÚ KAPSU
- (EE) OTSALÕPU KLAMBER
- (LT) GALINIO RIBOKLIO GEMBĖ
- (LV) GALA AIZTURA KRONŠTEINS

- (CZ) KONZOLA PRO DOJAZDOVOU KAPSU
- (RO) OPRITOR CURSĂ CONSOLĂ
- (HR) KONZOLA GRANIČNIKA
- (RUS) КРОНШТЕЙН УПЛАВЛИВАТЕЛЯ
- (SLO) OPORNIK ZAUSTAVLJALNIKA
- (TR) UÇ TESPİT PARÇASI DIRSEĞİ
- (AR) مقاعد المقاعد الطرفية
- (CHN) 终点挡块支座
- (MAL) PENDAKAP PENYENDAL Hujung
- (H) ÜTKÖZŐ-KERET
- (IL) תופסן למקביל קצה
- (BG) СКОБА ЗА СТОПЕР
- (KO) 종단 장치대 브래킷
- (SRB) KONZOLA GRANIČNIKA

Art.	L	A	B	C	E	G	J	K	S	END STOP	1pc			CODE
											kg	pcs	kg	
mm														
PARK	175	170	88	95	50	11x132	12x30	46	4	LAST/PADDOCK	1,11	2	2,22	1700006
PARK 240	245	170	88	95	50	11x200	12x30	46	4	LAST/PADDOCK	1,35	2	2,7	1700196

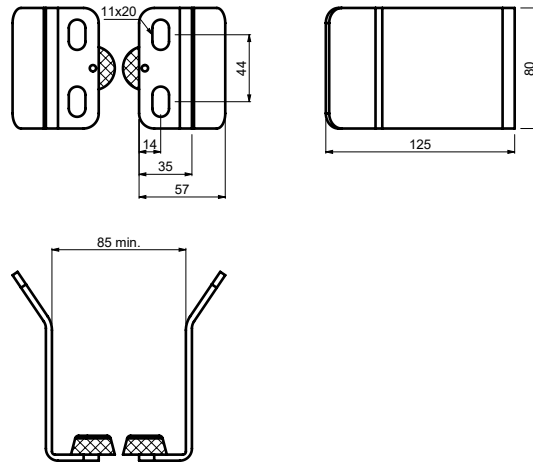
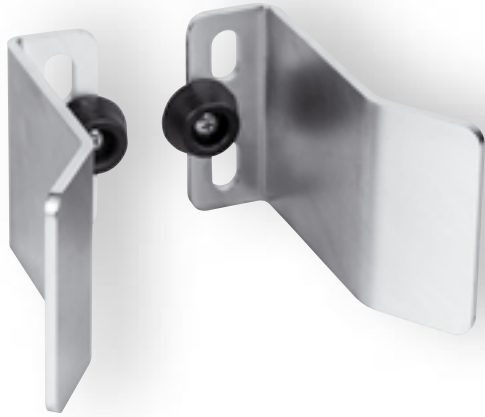

- (GB) END STOP
- (D) ENDANSCHLAG
- (F) BUTÉE
- (E) TOPE FINAL
- (P) FIM DE CORSO
- (I) ARRESTO TERMINALE
- (DK) ENDESTOP
- (NL) EINDSTOP
- (N) ENDESTOPP
- (S) ÄNDSTOPP
- (FIN) RAJOITIN
- (PL) ZDERZAK KRAŃCOWY
- (SK) DORAZ
- (EE) OTSA LÖPP
- (LT) GALINIS RIBOKLIS
- (LV) GALA AIZTURIS

- (CZ) KONCOVÝ DORAZ
- (RO) OPRITOR FINAL
- (HR) GRANIČNIK
- (RUS) КОНЦЕВОЙ УПОР
- (SLO) KONČNI ELEMENT
- (TR) UÇ TIPASI
- (AR) نقطة التوقف
- (CHN) 限位挡块
- (MAL) ADANG HUIJUNG
- (H) VÉGÜTKÖZŐ
- (IL) מקבל מתכוון עם מעצור גומי
- (BG) СТОПЕР
- (KO) 종단 장치대
- (SRB) GRANIČNIK

Art.	BRACKET	1pc		CODE
		kg	pcs	
PADDOCK SM	PARK/PARK 240	0,78	2	1700194

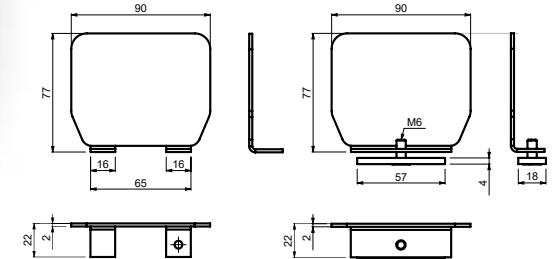

- (GB) GUIDE END CAP WITHOUT SCREW, DEPENDENT ON SUPPORT WHEEL  
GUIDE END CAP WITH SCREW, INDEPENDENT
- (D) ABSCHLUSSKAPPE FÜR „C“ PROFIL, ABHÄNGIG VON EINLAUFSCUH OHNE SCHRAUBE  
ABSCHLUSSKAPPE FÜR „C“ PROFIL, ABHÄNGIG VON EINLAUFSCUH OHNE SCHRAUBE
- (F) CACHE EXTRÉMITÉ POUR GUIDE SANS VIS, DÉPENDANT DE LA ROUE DE SUPPORT  
CACHE D'EMBOÛT DE GUIDE AVEC VIS, INDÉPENDANT
- (E) TOPE FINAL DE GUÍA SIN TUERCA, DEPENDIENTE DE LA RUEDA DE SOPORTE  
TOPE FINAL DE GUÍA CON TUERCA, INDEPENDIENTE
- (P) TAMPA FINAL GUIA SEM PARAFUSO, DEPENDENTE DA ROLDANA DO SUPORTE  
TAMPA FINAL GUIA COM PARAFUSO, INDEPENDENTE
- (I) COPERTURA TERMINALE DELLA GUIDA SENZA VITE, DIPENDENTE DALLA RUOTA DI SOSTEGNO.  
COPERTURA TERMINALE DELLA GUIDA CON VITE, INDEPENDENTE
- (DK) VANGENDEHÆTTE UDEN SKRUE, AFHÆNGIG AF STØTTEHJUL  
VANGENDEHÆTTE MED SKRUE, UAFHÆNGIG
- (NL) GELEIDER EINDKAP ZONDER SCHROEF, AFHANKELIJK VAN DRAAGWIEL  
GELEIDER EINDKAP MET SCHROEF, ONAFHANKELIJK
- (N) ENDEBESLAG TIL SKINNE UTEN SKRUE, FESTES PÅ STØTTEHJUL  
ENDEBESLAG TIL SKINNE MED SKRUE, UAFHÆNGIG
- (S) GEJD SKYDDSKÅPA UTAN SKRUV, BEROENDE PÅ STÖDHJUL  
GEJD SKYDDSKÅPA MED SKRUV, OBEROENDE
- (FIN) OHJAIMEN PÄÄN KANSI ILMAN RUUVIA, ERILLINEN TUKIPYÖRÄSSÄ  
OHJAIMEN PÄÄN RUUVILLINEN KANSI, ERILLINEN
- (PL) ZASLEPKA KOŃCOWA SZYNY BEZ ŚRUBY, ZALEŻNA OD ROLKI NAJZDOWEJ  
ZASLEPKA KOŃCOWA SZYNY ZE ŚRUBĄ, NIEZALEŻNA
- (SK) ZÁSLEPKA PRE NOSNÝ „C“ PROFIL, ZÁVISLÁ NA NÁBEHU BEZ SKRUTKY  
A NEZÁVISLÁ SO SKRUTKOU
- (EE) JUHIKU OTSAKORIK ILMA KRUVITA, SÕLTVALT TUGIRATTAST  
JUHIKU OTSAKORIK KRUVIGA, ERALDI
- (LT) KREIPTUVO GALINIS DANGTELIS BE SRIEGIO, SUSIETAS SU ATRAMINIU RATUKU  
KREIPTUVO GALINIS DANGTELIS SU SRIEGIO, ATSKIRAS
- (LV) „VADOTNES GALA VĀKS BEZ SKRŪVES, ATKARĪGS NO BALSTA RULLIŠA  
VADOTNES GALA VĀKS AR SKRŪVI, NEATKARĪGS“
- (CZ) ZÁSLEPKA PRO ŠINU „C“ PROFIL, ZÁVISLÁ NA NÁBĚHU BEZ ŠROUBU A NEZÁVISLÁ SE ŠROUBEM
- (RO) ACOPERIRE OPRITOR CURSĂ FĂRĂ FILET, ÎN FUNCȚIE DE ROATA DE SUSȚINERE  
OPRITOR CURSĂ ACOPERIRE GHIDAJ CU FILET, INDEPENDENT
- (HR) ČEP VODILICE BEZ VIJKA, OVISNO O NOSIVOM KOTAČU  
ČEP VODILICE S VIJKOM, NEOVISAN
- (RUS) ЗАПЛИШКА НАПРАВЛЯЮЩЕГО РЕЛЬСА «С», ЗАВИСИМАЯ ОТ КОНЦЕВОГО РОЛИКА  
БЕЗ ВИНТА И НЕЗАВИСИМАЯ С ВИНТОМ
- (SLO) ZAKLJUČNI POKROV VODILA BREZ VIJAKA, ODVIŠEN OD ZAKLJUČNEGA  
POKROVA VODILA PODPORNEGA KOLESA Z VIJAKOM, NEODVIŠEN
- (TR) VIDASIZ KIZAK UÇ LASTIĞI, DESTEK TEKERLEĞİNE BAĞLI  
VIDALI KIZAK UÇ LASTIĞI, BAĞIMSIZ
- (AR) عطاء نهائي بدون برغي، على حسب عجلة الدعامه  
عطاء نهائي مع برغي، مستقل
- (CHN) 非螺钉紧固导轨端盖，支轮支撑  
导轨独立式螺钉紧固端盖
- (MAL) PENUTUP HUIJUNG PANDU TANPA SKRU, BERGANTUNG PADA RODA SOKONGAN  
PENUTUP HUIJUNG PANDU DENGAN SKRU, BEBAS
- (H) VEZETŐSÍN LEZÁRÓ-ELEM CSAVARRAL, TÁMASZTÓGÖRGŐTŐL FÜGG  
VEZETŐSÍN LEZÁRÓ-ELEM CSAVARRAL, FÜGGTELLEN
- (IL) מסכה לקצה קרונית ללא ברזג תומך גלגל תמיכה  
מסכה לקצה קרונית עם ברזג תמיכה
- (BG) КРАЙНА КАПАЧКА ЗА РЕЛСА БЕЗ ВИНТ, ЗАВИСИМА ОТ РОЛИКАТА ЗА КОНЗОЛНА РЕЛСА  
КРАЙНА КАПАЧКА ЗА РЕЛСА С ВИНТ, САМОСТОЯТЕЛНА
- (KO) 나사가 없는 가이드 종단 캡, 지지용 휠에 의존  
나사가 있는 가이드 종단 캡, 독립식
- (SRB) ČEP VODICE BEZ ZAVRTNJA, ZAVISAN OD NOSEČEG TOČIČKA  
ČEP VODICE SA ZAVRTNJEM, NEZAVISAN

Art.	GUIDE	1pc		CODE
		kg	pcs	
PILOT M	STAGE MB/MZ	0,11	10	1700015
PILOT MN	STAGE MB/MZ	0,15	10	1700016

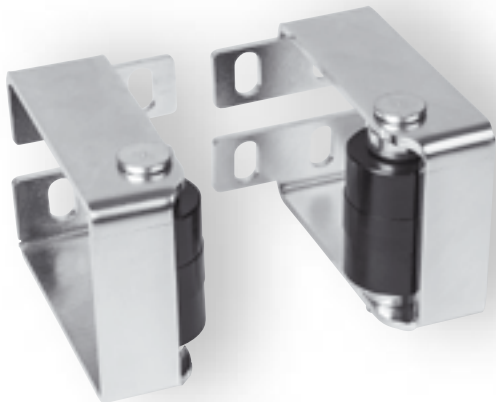

CAIS INNOVATION

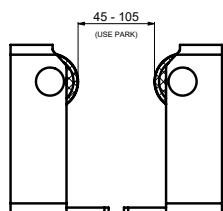
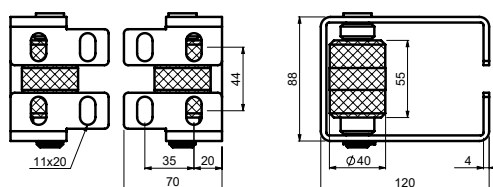
FAIL-SAFE  
ROLLER MECHANISM

- (GB) END STOP WITH ROLLER
- (D) ENDANSCHLAG MIT ROLLE
- (F) BUTÉE AVEC ROULEAU
- (E) TOPE FINAL CON RODILLO
- (P) FIM DE CURSO COM ROLO
- (I) ARRESTO TERMINALE CON RULLO
- (DK) ENDESTOP MED VALSE
- (NL) EINDSTOP MET ROLLEN
- (N) ENDESTOPP MED RULLE
- (S) ÄNDSTOPP MED RULLE
- (FIN) RAJOITIN RULLALLA
- (PL) ZDERZAK KRAŃCOWY Z ROLKĄ
- (SK) DORAZ S VALČEKOM
- (EE) OTSALÕPP RULLIKUGA
- (LT) GALINIS RIBOKLIS SU RITINĖLIU
- (LV) GALA AIZTURIS AR RULLITI

- (CZ) KONCOVÝ DORAZ S KLADKOU
- (RO) OPRITOR FINAL CU ROLĂ
- (HR) GRANIČNIK S VALJKOM
- (RUS) КОНЦЕВОЙ УПОР С РОЛИКОМ
- (SLO) KONČNI ELEMENT S KOLESCEM
- (TR) MAKARALI UÇ TIPASI
- (AR) نقطة التوقف المزودة بكرة
- (CHN) 帶繩子的限位擋塊
- (MAL) ADANG HUJUNG DENGAN PENGGELEK
- (H) VÉGÜTKÖZŐ GÖRGŐVEL
- (IL) מקביל קצה עם גלגלי אוקולון
- (BG) СТОПЕР С РОЛКА
- (KO) 롤러가 있는 종단 장치대
- (SRB) GRANIČNIK SA VALJKOM

Art.	BRACKET	1pc			CODE
		kg	pcs	kg	
PADDOCK 2	PARK/PARK 240	1,4	2	2,8	1700182

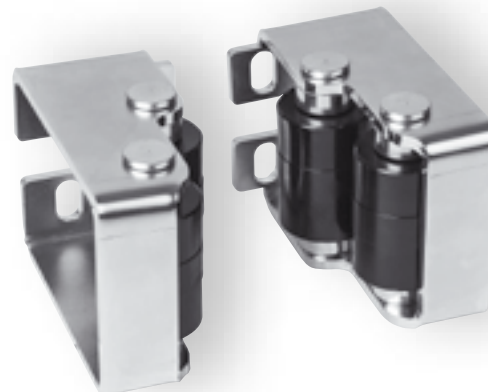

CAIS INNOVATION

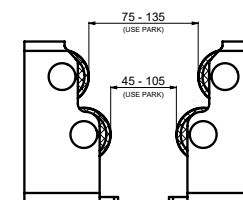
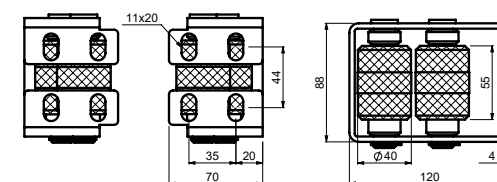
FAIL-SAFE  
ROLLER MECHANISM

- (GB) END STOP WITH ROLLER
- (D) ENDANSCHLAG MIT ROLLE
- (F) BUTÉE AVEC ROULEAU
- (E) TOPE FINAL CON RODILLO
- (P) FIM DE CURSO COM ROLO
- (I) ARRESTO TERMINALE CON RULLO
- (DK) ENDESTOP MED VALSE
- (NL) EINDSTOP MET ROLLEN
- (N) ENDESTOPP MED RULLE
- (S) ÄNDSTOPP MED RULLE
- (FIN) RAJOITIN RULLALLA
- (PL) ZDERZAK KRAŃCOWY Z ROLKĄ
- (SK) DORAZ S VALČEKOM
- (EE) OTSALÕPP RULLIKUGA
- (LT) GALINIS RIBOKLIS SU RITINĖLIU
- (LV) GALA AIZTURIS AR RULLITI

- (CZ) KONCOVÝ DORAZ S KLADKOU
- (RO) OPRITOR FINAL CU ROLĂ
- (HR) GRANIČNIK S VALJKOM
- (RUS) КОНЦЕВОЙ УПОР С РОЛИКОМ
- (SLO) KONČNI ELEMENT S KOLESCEM
- (TR) MAKARALI UÇ TIPASI
- (AR) نقطة التوقف المزودة بكرة
- (CHN) 帶繩子的限位擋塊
- (MAL) ADANG HUJUNG DENGAN PENGGELEK
- (H) VÉGÜTKÖZŐ GÖRGŐVEL
- (IL) מקביל קצה עם גלגלי אוקולון
- (BG) СТОПЕР С РОЛКА
- (KO) 롤러가 있는 종단 장치대
- (SRB) GRANIČNIK SA VALJKOM

Art.	BRACKET	1pc			CODE
		kg	pc	kg	
PADDOCK 4	PARK/PARK 240	2,1	1	2,1	1700191

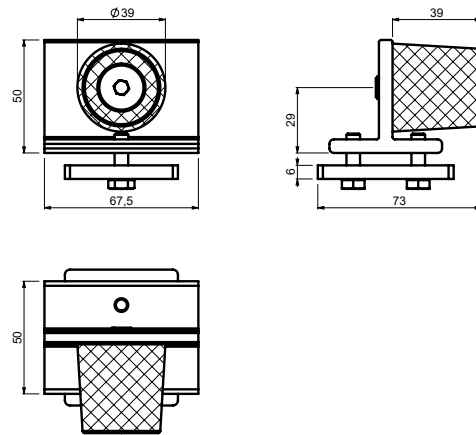
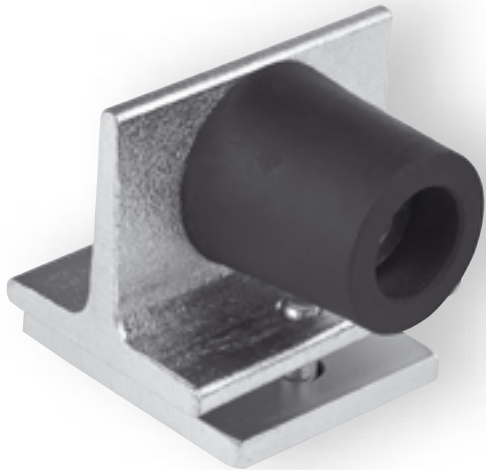

- (GB) INTERNAL GUIDE END STOP
- (D) INNENANSCHLAG FÜR „C“ PROFIL
- (F) BUTÉE INTERNE POUR GUIDE
- (E) TOPE FINAL DE GUÍA INTERNA
- (P) BATENTE GUIA INTERNA
- (I) FERMO DI FINE CORSA DELLA GUIDA INTERNA
- (DK) INTERN VANGEENDESTOP
- (NL) INTERNE GELEIDER EINDSTOP
- (N) ENDESTOPPER TIL INNVENDIG SKINNE
- (S) INTERNT GEJDÄNDSTOPP
- (FIN) SISÄINEN OHJAIMEN PÄÄN PYSÄYTIN
- (PL) WEWNĘTRZNY ODBOJNIK SZYNY
- (SK) DORAZ VNÚTORNÝ PRE NOSNÝ „C“ PROFIL
- (EE) SISEJUHIKU OTSALÕPP
- (LT) VIDINIO KREIPTUVO GALINIS RIBOKLIS
- (LV) IEKŠĒJAIS VADOTNES GALA AIZTURIS

- (CZ) DORAZ VNITŘNÍ PRO ŠÍNU „C“ PROFIL
- (RO) GHIDAJ CAPĂT FINAL INTERN
- (HR) UNUTARNJI GRANIČNIK VODILICE
- (RUS) ВНУТРЕННИЙ ОГРАНИЧИТЕЛЬ НАПРАВЛЯЮЩЕГО РЕЛЬСА «С»
- (SLO) ZAUSTAVLJALNIK NOTRANJEGA VODILA
- (TR) DAHİLİ KIZAK UÇ TESPİT PARÇASI
- (AR) ممانع طرفي داخلي
- (CHN) 内导轨终点挡块
- (MAL) PENYENDAL Hujung Pandu Dalam
- (H) VEZETŐSÍN BELSŐ ÜTKÖZŐ
- (IL) מצמד פנימי גומי לקורה
- (BG) ВЪТРЕШЕН СТОПЕР ЗА РЕЛСА
- (KO) 내부 가이드 종단 정지대
- (SRB) UNUTRAŠNJI GRANIČNIK VOĐICE

Art.	GUIDE	1pc			CODE
		kg	pcs	kg	
FINISH M	STAGE MB/MZ	0,48	10	4,8	1700017

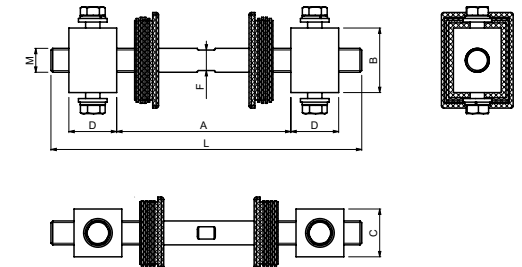

- (GB) ADJUSTABLE TENSION BAR FOR CANTILEVER GATE
- (D) EINSTELLBARE ZUGSTANGE FÜR AUSLEGERTOR
- (F) BARRE DE TENSION RÉGLABLE POUR PORTAIL COULISSANT AUTOPORTANT
- (E) BARRA TENSORA AJUSTABLE PARA PORTÓN EN VOLADIZO
- (P) BARRA DE TENSÃO AJUSTÁVEL PARA PORTÃO CANTILEVER
- (I) TIRANTE DI REGOLAZIONE PER CANCELLO AUTOPORTANTE
- (DK) JUSTERBAR SPÆNDINGSSTANG TIL FRITBÆRENDE PORT
- (NL) VERSTELBARE SPANNINGSBAK VOOR SCHUIFPOORT
- (N) JUSTERBAR STREKKSTANG FOR RULLEPORT
- (S) JUSTERBAR SPÄNNINGSSTÄNG FÖR FRIBÄRANDE GRIND
- (FIN) SÄÄDETTÄVÄ KIRISTYSTANKO ULOKEPORTTIIN
- (PL) REGULOWANA LISTWA NAPINAJĄCA DO BRAMY SAMONOŚNEJ
- (SK) NASTAVITELNÁ ŤAŽNÁ TYČ PRE SAMONOŠNÉ BRÁNY
- (EE) REGULEERITAV PINGUTUSTALA KONSOLVÄRAVA JAOKS
- (LT) REGULIUOJAMA TRAUKĖ GEMBINIAMS VARTAMS
- (LV) REGULĒJAMS STĒPNIS KONSOLVEIDA VĀRTIEM

- (CZ) TENZNÍ TYČ S REGULACÍ PRO POSUVNOU SAMONOSNOU BRÁNU
- (RO) BARĂ DE TENSIUNE REGLABILĂ PENTRU POARTĂ ÎN CONSOLĂ
- (HR) PRILAGODLJIVA STEZNA ŠIPKA ZA NOSIVA VRATA
- (RUS) РЕГУЛИРУЕМЫЙ РАСТЯНУТЫЙ СТЕРЖЕНЬ ДЛЯ САМОНЕСУЩИХ ВОРОТ
- (SLO) NASTAVLJIV NAPENJALNI VZVOD ZA SAMONOSNA DRŠNA VRATA
- (TR) MANIVELA KAPI İÇİN AYARLANABİLİR GERİLİM ÇUBUĞU
- (AR) قضيب الشد القابل للتعديل لوابية الكابول
- (CHN) 可调节悬臂门拉杆
- (MAL) BAR TEGANGAN BOLEH LARAS UNTUK GET JULUR
- (H) ÁLLÍTHATÓ FESZÍTŐRŰD TOLÓKAPUHOZ
- (IL) מוט מתוחה מתכוונן לשער קבוע
- (BG) РЕГУЛИРУЕМ ОБТЕГАЧ ЗА КОНЗОЛНА ВРАТА
- (KO) 캔틸레버 게이트용 조절식 인장대
- (SRB) PODESIVA ZATEZNA ŠIPKA ZA SAMONOSIVU KAPJIVU

Art.		L	A min./max.	B	C	D	M	F	1pc			CODE
									kg	pcs	kg	
DIAGON 60	60x40	260	125 - 170	34	40	40	M20	17	1,39	2	2,78	1700237
DIAGON 80	80x60/60x60	260	125 - 180	54	40	40	M20	17	1,95	2	3,9	1700238

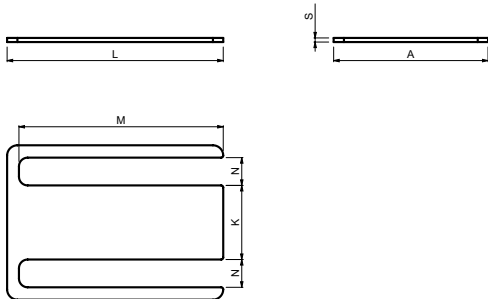

- (GB) WASHER FOR CANTILEVER CARRIAGE
- (D) UNTERLEGSCHIBE FÜR AUSLEGERSCHLITTEN
- (F) RONDELLE POUR CHARIOT CANTILEVER
- (E) TUERCA PARA CARRO EN VOLADIZO
- (P) ARRUELA PARA TRANSPORTE DE CANTILEVER
- (I) RONDELLA PER CARRELLO CANCELLO AUTOPORTANTE
- (DK) SKIVE TIL FRITBÆRENDE PORT
- (NL) RING VOOR SCHUIFWAGEN
- (N) SKIVE FOR RULLEPORTVOGN
- (S) BRICKA FÖR FRIBÄRANDE GRINDVAGN
- (FIN) ALUSLEVY ULOKETELINEESEEN
- (PL) PODKŁADKA DO WÓZKA BRAMY SAMONOŠNEJ
- (SK) PODLOŽKA PRE SAMONOSNÝ NOSNÍK
- (EE) SEIB KONSOOLALUSE JAOKS
- (LT) POVERŽLĖ GEMBINIŲ VARTŲ VEŽIMĖLIUI
- (LV) PĀPLĀKSNE KONSOLĒS NESOŠĀJAM RULĻU BLOKAM

- (CZ) PODLOŽKA PRO VOZÍK
- (RO) ȘAIBĂ PENTRU SISTEMUL DE CULISARE ÎN CONSOLĂ
- (HR) PODLOŠKA ZA NOSIVO PODVOZJE
- (RUS) ШАЙБА ДЛЯ РОЛИКОВЫХ ТЕЛЕЖЕК САМОНЕСУЩИХ ВОРОТ
- (SLO) PODLOŽKA ZA VOZIČEK
- (TR) MANIVELA TAŞIYICISI İÇİN RONDELA
- (AR) حلبة لثوابية الكابول
- (CHN) 悬臂架垫片
- (MAL) SESENDAL UNTUK PEMBAWA JULUR
- (H) ALÁTÉT TOLÓKAPU FUTÓKOCSIHOZ
- (IL) חלקה לרגליים לרובוט
- (BG) ВЛОЖКА ЗА КОНЗОЛНА КОЛИЧКА
- (KO) 캔틸레버 이송대용 와셔
- (SRB) PODLOŠKA ZA SAMONOSIVU KARIJU

Art.	L	A	K	M	N	S	CARRIAGE	1pc	CODE			
								kg	pcs	kg		
	mm											
DESK ME 2	210	150	72	199	27	2	SPEED ME	0,32	4	1,28	1700323	
DESK ME 4	210	150	72	199	27	4	SPEED ME	0,64	4	2,56	1700324	
DESK ME 6	210	150	72	199	27	6	SPEED ME	0,96	4	3,84	1700325	

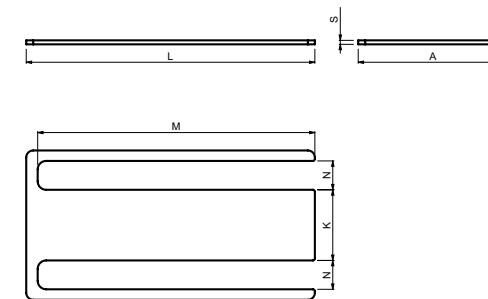

- (GB) WASHER FOR CANTILEVER CARRIAGE
- (D) UNTERLEGSCHIBE FÜR AUSLEGERSCHLITTEN
- (F) RONDELLE POUR CHARIOT CANTILEVER
- (E) TUERCA PARA CARRO EN VOLADIZO
- (P) ARRUELA PARA TRANSPORTE DE CANTILEVER
- (I) RONDELLA PER CARRELLO CANCELLO AUTOPORTANTE
- (DK) SKIVE TIL FRITBÆRENDE PORT
- (NL) RING VOOR SCHUIFWAGEN
- (N) SKIVE FOR RULLEPORTVOGN
- (S) BRICKA FÖR FRIBÄRANDE GRINDVAGN
- (FIN) ALUSLEVY ULOKETELINEESEEN
- (PL) PODKŁADKA DO WÓZKA BRAMY SAMONOŠNEJ
- (SK) PODLOŽKA PRE SAMONOSNÝ NOSNÍK
- (EE) SEIB KONSOOLALUSE JAOKS
- (LT) POVERŽLĖ GEMBINIŲ VARTŲ VEŽIMĖLIUI
- (LV) PĀPLĀKSNE KONSOLĒS NESOŠĀJAM RULĻU BLOKAM

- (CZ) PODLOŽKA PRO VOZÍK
- (RO) ȘAIBĂ PENTRU SISTEMUL DE CULISARE ÎN CONSOLĂ
- (HR) PODLOŠKA ZA NOSIVO PODVOZJE
- (RUS) ШАЙБА ДЛЯ РОЛИКОВЫХ ТЕЛЕЖЕК САМОНЕСУЩИХ ВОРОТ
- (SLO) PODLOŽKA ZA VOZIČEK
- (TR) MANIVELA TAŞIYICISI İÇİN RONDELA
- (AR) حلبة لثوابية الكابول
- (CHN) 悬臂架垫片
- (MAL) SESENDAL UNTUK PEMBAWA JULUR
- (H) ALÁTÉT TOLÓKAPU FUTÓKOCSIHOZ
- (IL) חלקה לרגליים לרובוט
- (BG) ВЛОЖКА ЗА КОНЗОЛНА КОЛИЧКА
- (KO) 캔틸레버 이송대용 와셔
- (SRB) PODLOŠKA ZA SAMONOSIVU KARIJU

Art.	L	A	K	M	N	S	CARRIAGE	1pc	CODE		
								kg	pcs	kg	
	mm										
DESK M 2	290	150	72	279	27	2	SPEED M	0,42	4	1,68	1700326
DESK M 4	290	150	72	279	27	4	SPEED M	0,84	4	3,36	1700327
DESK M 6	290	150	72	279	27	6	SPEED M	1,26	4	5,04	1700328

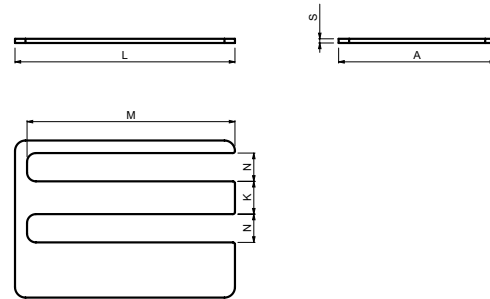

- (GB) WASHER FOR CANTILEVER CARRIAGE
- (D) UNTERLEGSCHIBE FÜR AUSLEGERSCHLITTEN
- (F) RONDELLE POUR CHARIOT CANTILEVER
- (E) TUERCA PARA CARRO EN VOLADIZO
- (P) ARRUELA PARA TRANSPORTE DE CANTILEVER
- (I) RONDELLA PER CARRELLO CANCELLO AUTOPORTANTE
- (DK) SKIVE TIL FRITBÆRENDE PORT
- (NL) RING VOOR SCHUIFWAGEN
- (N) SKIVE FOR RULLEPORTVOGN
- (S) BRICKA FÖR FRIBÄRANDE GRINDVAGN
- (FIN) ALUSLEVY ULOKETELINEESEEN
- (PL) PODKŁADKA DO WÓZKA BRAMY SAMONOŚNEJ
- (SK) PODLOŽKA PRE SAMONOSNÝ NOSNÍK
- (EE) SEIB KONSOOLALUSE JAOKS
- (LT) POVERŽLĖ GEMBINIŲ VARTŲ VEŽIMĖLIUI
- (LV) PĀPLĀKSNE KONSOLĒS NESOŠĀJAM RUĻĻU BLOKAM

- (CZ) PODLOŽKA PRO VOZÍK
- (RO) ȘAIBĂ PENTRU SISTEMUL DE CULISARE ÎN CONSOLĂ
- (HR) PODLOŠKA ZA NOSIVO PODVOZJE
- (RUS) ШАЙБА ДЛЯ РОЛИКОВЫХ ТЕЛЕЖЕК САМОНЕСУЩИХ ВОРОТ
- (SLO) PODLOŽKA ZA VOZIČEK
- (TR) MANİVELA TAŞIYICISI İÇİN RONDELA
- (AR) حجة لنوابية الكترول
- (CHN) 悬臂架垫片
- (MAL) SESENDAL UNTUK PEMBAWA JULUR
- (H) ALÁTÉT TOLÓKAPU FUTÓKOCSIHOZ
- (IL) הקטן לדגלים לקומות
- (BG) ВЛОЖКА ЗА КОНЗОЛНА КОЛИЧКА
- (KO) 캔틸레버 이송대용 와셔
- (SRB) PODLOŠKA ZA SAMONOSIVU KAPIJU

Art.	L	A	K	M	N	S	CARRIAGE	1pc			CODE
								kg	pcs	kg	
	mm										
DESK MEK 2	210	150	72	199	27	2	SPEED MEK	0,32	4	1,28	1700329
DESK MEK 4	210	150	72	199	27	4	SPEED MEK	0,64	4	2,56	1700330
DESK MEK 6	210	150	72	199	27	6	SPEED MEK	0,96	4	3,84	1700331

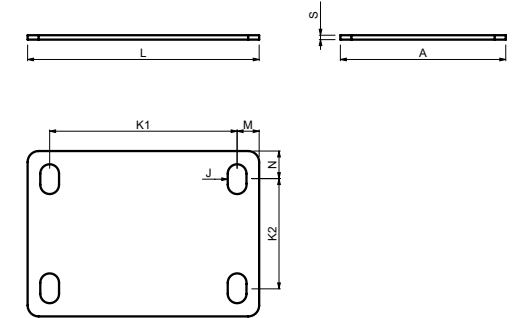

- (GB) WASHER FOR CANTILEVER CARRIAGE
- (D) UNTERLEGSCHIBE FÜR AUSLEGERSCHLITTEN
- (F) RONDELLE POUR CHARIOT CANTILEVER
- (E) TUERCA PARA CARRO EN VOLADIZO
- (P) ARRUELA PARA TRANSPORTE DE CANTILEVER
- (I) RONDELLA PER CARRELLO CANCELLO AUTOPORTANTE
- (DK) SKIVE TIL FRITBÆRENDE PORT
- (NL) RING VOOR SCHUIFWAGEN
- (N) SKIVE FOR RULLEPORTVOGN
- (S) BRICKA FÖR FRIBÄRANDE GRINDVAGN
- (FIN) ALUSLEVY ULOKETELINEESEEN
- (PL) PODKŁADKA DO WÓZKA BRAMY SAMONOŚNEJ
- (SK) PODLOŽKA PRE SAMONOSNÝ NOSNÍK
- (EE) SEIB KONSOOLALUSE JAOKS
- (LT) POVERŽLĖ GEMBINIŲ VARTŲ VEŽIMĖLIUI
- (LV) PĀPLĀKSNE KONSOLĒS NESOŠĀJAM RUĻĻU BLOKAM

- (CZ) PODLOŽKA PRO VOZÍK
- (RO) ȘAIBĂ PENTRU SISTEMUL DE CULISARE ÎN CONSOLĂ
- (HR) PODLOŠKA ZA NOSIVO PODVOZJE
- (RUS) ШАЙБА ДЛЯ РОЛИКОВЫХ ТЕЛЕЖЕК САМОНЕСУЩИХ ВОРОТ
- (SLO) PODLOŽKA ZA VOZIČEK
- (TR) MANİVELA TAŞIYICISI İÇİN RONDELA
- (AR) حجة لنوابية الكترول
- (CHN) 悬臂架垫片
- (MAL) SESENDAL UNTUK PEMBAWA JULUR
- (H) ALÁTÉT TOLÓKAPU FUTÓKOCSIHOZ
- (IL) הקטן לדגלים לקומות
- (BG) ВЛОЖКА ЗА КОНЗОЛНА КОЛИЧКА
- (KO) 캔틸레버 이송대용 와셔
- (SRB) PODLOŠKA ZA SAMONOSIVU KAPIJU

Art.	L	A	J	K1	K2	M	N	S	CARRIAGE	1pc			CODE
										kg	pcs	kg	
	mm												
RAMP ME 2	210	150	17x27	170	99	20	25,5	2	SPEED ME	0,48	4	1,92	1700292
RAMP ME 4	210	150	17x27	170	99	20	25,5	4	SPEED ME	0,89	4	3,56	1700293
RAMP ME 6	210	150	17x27	170	99	20	25,5	6	SPEED ME	1,34	4	5,36	1700294



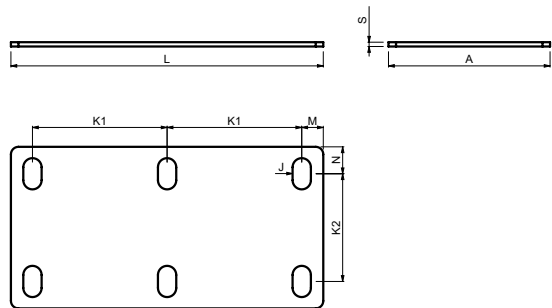

- (GB) WASHER FOR CANTILEVER CARRIAGE
- (D) UNTERLEGSCHIEBE FÜR AUSLEGERSCHLITTEN
- (F) RONDELLE POUR CHARIOT CANTILEVER
- (E) TUERCA PARA CARRO EN VOLADIZO
- (P) ARRUELA PARA TRANSPORTE DE CANTILEVER
- (I) RONDELLA PER CARRELLO CANCELLO AUTOPORTANTE
- (DK) SKIVE TIL FRITBÆRENDE PORT
- (NL) RING VOOR SCHUIFWAGEN
- (N) SKIVE FOR RULLEPORTVOGN
- (S) BRICKA FÖR FRIBÄRANDE GRINDVAGN
- (FIN) ALUSLEVY ULOKETELINEESEEN
- (PL) PODKŁADKA DO WÓZKA BRAMY SAMONOŚNEJ
- (SK) PODLOŽKA PRE SAMONOSNÝ NOSNÍK
- (EE) SEIB KONSOOLALUSE JAOKS
- (LT) POVERŽLĖ GEMBINIŲ VARTŲ VEŽIMĖLIUI
- (LV) PĀPLĀKSNE KONSOLĒS NESOŠĀJAM RUĻĻU BLOKAM

- (CZ) PODLOŽKA PRO VOZÍK
- (RO) ȘAIBĂ PENTRU SISTEMUL DE CULISARE ÎN CONSOLĂ
- (HR) PODLOŠKA ZA NOSIVO PODVOZJE
- (RUS) ШАЙБА ДЛЯ РОЛИКОВЫХ ТЕЛЕЖЕК САМОНЕСУЩИХ ВОРОТ
- (SLO) PODLOŽKA ZA VOZIČEK
- (TR) MANİVELA TAŞIYICISI İÇİN RONDELA
- (AR) حلبة لثوابية الكابول
- (CHN) 悬臂架垫片
- (MAL) SESENDAL UNTUK PEMBAWA JULUR
- (H) ALÁTÉT TOLÓKAPU FUTÓKOCSIHOZ
- (IL) חסכת לרגליים לרובוט
- (BG) ВЛОЖКА ЗА КОНЗОЛНА КОЛИЧКА
- (KO) 캔틸레버 이송대용 와셔
- (SRB) PODLOŠKA ZA SAMONOSIVU KARIJU

Art.	L	A	J	K1	K2	M	N	S	CARRIAGE	1pc				CODE
											kg	pcs	kg	
mm														
RAMP M 2	290	150	17x27	125	99	20	25,5	2	SPEED M	0,65	4	2,6	1700295	
RAMP M 4	290	150	17x27	125	99	20	25,5	4	SPEED M	1,23	4	4,92	1700296	
RAMP M 6	290	150	17x27	125	99	20	25,5	6	SPEED M	1,85	4	7,4	1700297	

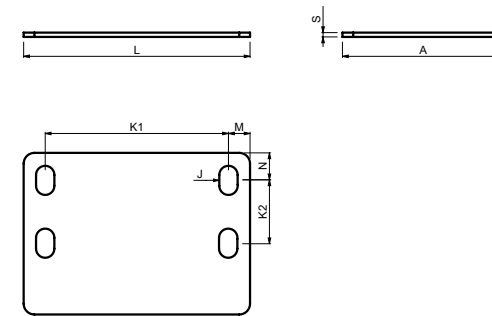

- (GB) WASHER FOR CANTILEVER CARRIAGE
- (D) UNTERLEGSCHIEBE FÜR AUSLEGERSCHLITTEN
- (F) RONDELLE POUR CHARIOT CANTILEVER
- (E) TUERCA PARA CARRO EN VOLADIZO
- (P) ARRUELA PARA TRANSPORTE DE CANTILEVER
- (I) RONDELLA PER CARRELLO CANCELLO AUTOPORTANTE
- (DK) SKIVE TIL FRITBÆRENDE PORT
- (NL) RING VOOR SCHUIFWAGEN
- (N) SKIVE FOR RULLEPORTVOGN
- (S) BRICKA FÖR FRIBÄRANDE GRINDVAGN
- (FIN) ALUSLEVY ULOKETELINEESEEN
- (PL) PODKŁADKA DO WÓZKA BRAMY SAMONOŚNEJ
- (SK) PODLOŽKA PRE SAMONOSNÝ NOSNÍK
- (EE) SEIB KONSOOLALUSE JAOKS
- (LT) POVERŽLĖ GEMBINIŲ VARTŲ VEŽIMĖLIUI
- (LV) PĀPLĀKSNE KONSOLĒS NESOŠĀJAM RUĻĻU BLOKAM

- (CZ) PODLOŽKA PRO VOZÍK
- (RO) ȘAIBĂ PENTRU SISTEMUL DE CULISARE ÎN CONSOLĂ
- (HR) PODLOŠKA ZA NOSIVO PODVOZJE
- (RUS) ШАЙБА ДЛЯ РОЛИКОВЫХ ТЕЛЕЖЕК САМОНЕСУЩИХ ВОРОТ
- (SLO) PODLOŽKA ZA VOZIČEK
- (TR) MANİVELA TAŞIYICISI İÇİN RONDELA
- (AR) حلبة لثوابية الكابول
- (CHN) 悬臂架垫片
- (MAL) SESENDAL UNTUK PEMBAWA JULUR
- (H) ALÁTÉT TOLÓKAPU FUTÓKOCSIHOZ
- (IL) חסכת לרגליים לרובוט
- (BG) ВЛОЖКА ЗА КОНЗОЛНА КОЛИЧКА
- (KO) 캔틸레버 이송대용 와셔
- (SRB) PODLOŠKA ZA SAMONOSIVU KARIJU

Art.	L	A	J	K1	K2	M	N	S	CARRIAGE	1pc				CODE
											kg	pcs	kg	
mm														
RAMP MEK 2	210	150	17x27	170	65	20	25,5	2	SPEED MEK	0,48	4	1,92	1700298	
RAMP MEK 4	210	150	17x27	170	65	20	25,5	4	SPEED MEK	0,89	4	3,56	1700299	
RAMP MEK 6	210	150	17x27	170	65	20	25,5	6	SPEED MEK	1,34	4	5,36	1700300	

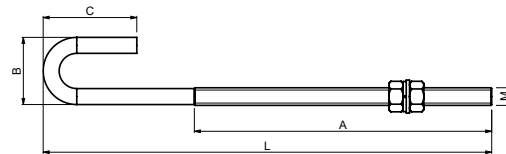

- (GB) FIXING BAR FOR CANTILEVER CARRIAGE
- (D) BEFESTIGUNGSSTANGE FÜR AUSLEGERSCHLITTEN
- (F) BARRE DE FIXATION POUR CHARIOT CANTILEVER
- (E) BARRA DE FIJACIÓN PARA CARRO EN VOLADIZO
- (P) BARRA DE FIXAÇÃO DE TRANSPORTE DE CANTILEVER
- (I) BARRA DI FISSAGGIO PER CARRELLO CANCELLO AUTOPORTANTE
- (DK) FASTGØRELSESSTANG TIL FRITBÆRENDE PORT
- (NL) BEVESTIGINGSBALK VOOR SCHUIFWAGEN
- (N) FESTESTANG FOR RULLEPORT
- (S) FÅSTBALK FÖR FRIBÄRANDE GRINDVAGN
- (FIN) KIINNITYSPALKKI ULOKETELINEESEEN
- (PL) LISTWA MOCUJĄCA DO WÓZKA BRAMY SAMONOŚNEJ
- (SK) UPEVNŔOVACIA TYČ PRE SAMONOSNÝ NOSNÍK
- (EE) FIKSEERIMISTALA KONSOLALUSE JAOKS
- (LT) TVIRTINIMO STRYPAS GEMBINIŲ VARTŲ VEŽIMĖLIUI
- (LV) FIKSĒJOŠAIS STIENIS KONSOLĒS NESOŠAJAM RUĻĻU BLOKAM

- (CZ) FIXNÍ TYČ PRO VOZÍK
- (RO) BARĂ DE FIXARE PENTRU SISTEMUL DE CULISARE ÎN CONSOLĂ
- (HR) FIKSIRAJUĆA ŠIPKA ZA NOSIVO PODVOZJE
- (RUS) КРЕПЕЖНЫЙ СТЕРЖЕНЬ ДЛЯ РОЛИКОВЫХ ТЕЛЕЖЕК САМОНЕСУЩИХ ВОРОТ
- (SLO) PRITRDILNI DROG ZA VOZIČEK
- (TR) MANIVELA TAŞIYICISI İÇİN SABITLEME ÇUBUĞU
- (AR) قضيب التثبيت لثوابت الكابول
- (CHN) 悬臂架固定条
- (MAL) BAR IKATAN UNTUK PEMBAWA JULUR
- (H) RÖGZITŐRÜD TOLÓKAPU FUTÓKOCSIHOZ
- (IL) מוט קיבוע לדגללים לקנודלי
- (BG) ФИКСАТОР ЗА КОНЗОЛНА КОЛИЧКА
- (KO) 캔틸레버 이송대용 고정대
- (SRB) FIKSIRAJUĆA ŠIPKA ZA SAMONOSIVU KAPIJU

Art.	L	A	B	C	M	WASHER	1pc				CODE
								kg	pcs	kg	
CLINCH 16	410	300	60	80	M16	RAMP	0,72	12	8,64	1700239	

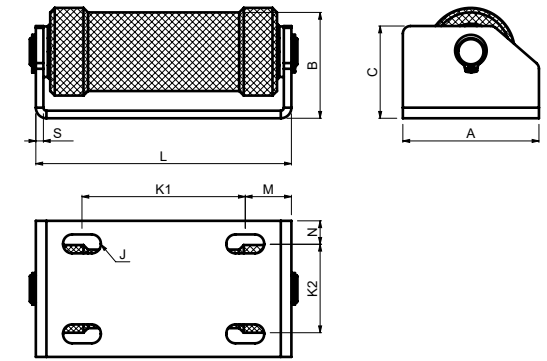

- (GB) SUPPORT ROLLER FOR CANTILEVER GATE
- (D) STÜTZROLLE FÜR AUSLEGERTOR
- (F) ROULEAU DE SUPPORT POUR PORTAIL COULISSANT AUTOPORTANT
- (E) RODILLO DE SOPORTE PARA PORTÓN EN VOLADIZO
- (P) ROLO DE SUPORTE PARA PORTÃO DE CANTILEVER
- (I) RULLO DI SOSTEGNO PER CANCELLO AUTOPORTANTE
- (DK) STØTTERULLE TIL FRITBÆRENDE PORT
- (NL) STEUNROL VOOR SCHUIFPOORT
- (N) STØTTERULLE FOR RULLEPORT
- (S) STÖDRULLE FÖR FRIBÄRANDE GRIND
- (FIN) TUKIRULLA ULOKEPORTTIIN
- (PL) ROLKA DOLNA DO BRAMY SAMONOŚNEJ
- (SK) PODPORNÝ VALEC PRE SAMONOSNÉ BRÁNY
- (EE) TUGIRULLIK KONSOLVÁRAVA JAOKS
- (LT) ATRAMINIS RITINĖLIS GEMBINIAMS VARTAMS
- (LV) BALSTA RULLĪTIS KONSOLVEIDA VĀRTIEM

- (CZ) KONZOLA S KLDKOU PRO PODPĚRU POSUVNÉ SAMONOSNÉ BRÁNY
- (RO) ROLĂ DE SUSȚINERE PENTRU POARTA ÎN CONSOLĂ
- (HR) POTPORNI VALJAK ZA NOSIVA VRATA
- (RUS) ОПОРНЫЙ РОЛИК ДЛЯ САМОНЕСУЩИХ ВОРОТ
- (SLO) PODPORNI VALJ ZA SAMONOSNA DRŠNA VRATA
- (TR) MANIVELA KAPI İÇİN DESTEK MAKARASI
- (AR) اسطوانة الدعم لثوابت الكابول
- (CHN) 悬臂门支撑棍
- (MAL) PENGELEK SOKONGAN UNTUK GET JULUR
- (H) TARTÓGÖRGŐ TOLÓKAPUHOZ
- (IL) רולל תמיכה לשיער קנודלי
- (BG) ПОДДЪРЖАЩА РОЛКА ЗА КОНЗОЛНА ВРАТА
- (KO) 캔틸레버 게이트용 지지 롤러
- (SRB) NOSEĆI VALJAK ZA SAMONOSIVU KAPIJU

Art.	L	A	B	C	J	K1	K2	M	N	S	1pc				CODE
												kg	pcs	kg	
DRIVESHAFT 80	144	90	70	73	13x25	107	60	31	15	5	1,37	4	5,48	1700332	
DRIVESHAFT 100	169	90	70	73	13x25	107	60	31	15	5	1,56	4	6,24	1700333	



DESIGNED FOR  
STRAIGHT ROLLING  
MOVEMENT

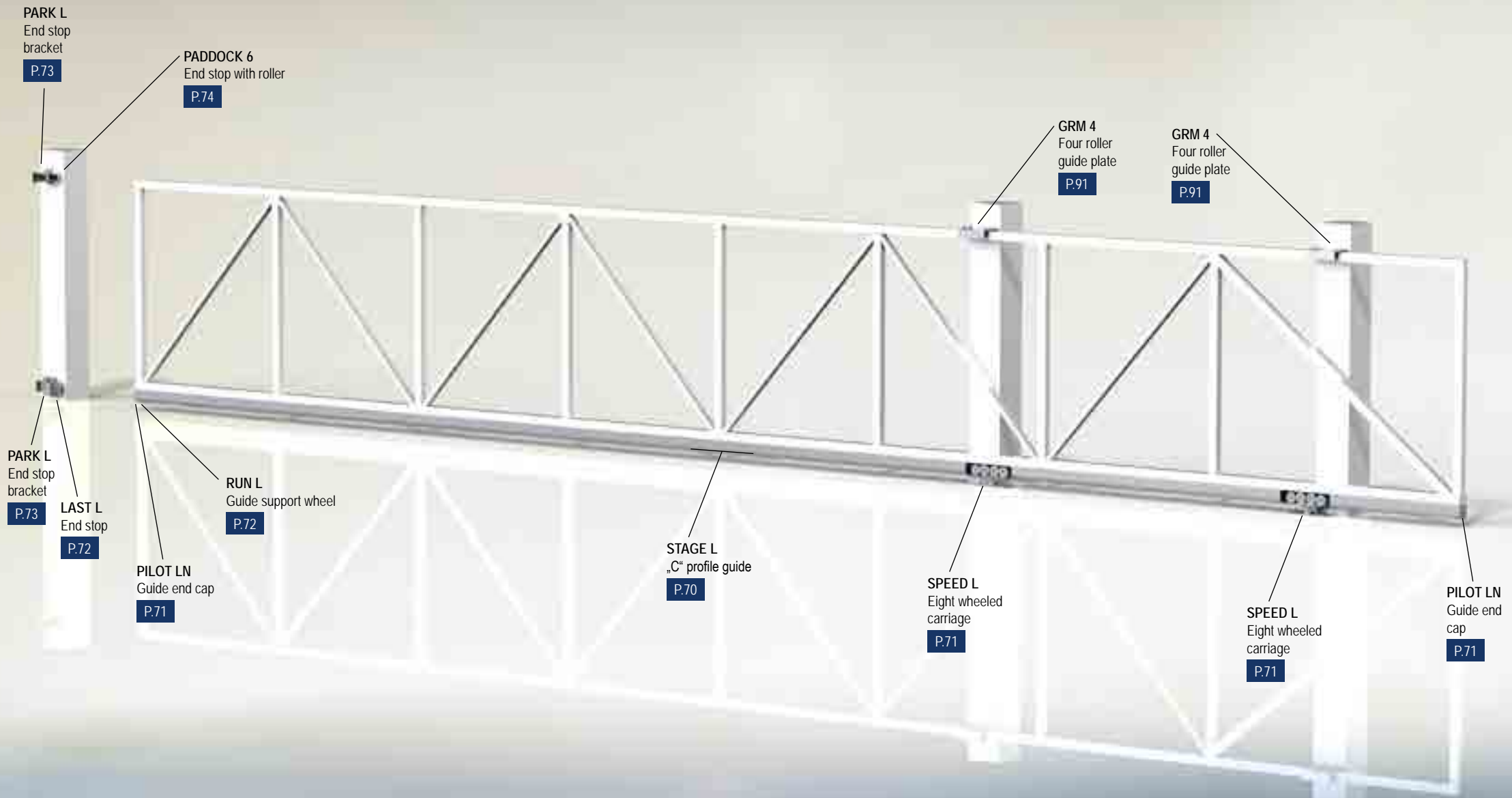

**CAIS** CANTILEVER L 13.5

CANTILEVER HARDWARE

CANTILEVER L												
	mm: kg	mm: kg	mm: kg	mm: kg	mm: kg	mm: kg	mm: kg	mm: kg	mm: kg	mm: kg	mm: kg	mm: kg
A	8000	8500	9000	9500	10000	10500	11000	11500	12000	12500	13000	13500
max. weight gate	925 kg	950 kg	975 kg	1000 kg	1025 kg	1050 kg	1075 kg	1100 kg	1125 kg	1150 kg	1175 kg	1200 kg
B	2400	2550	2700	2850	3000	3150	3300	3450	3600	3750	3900	4050
C	3300	3450	3600	3750	3900	4050	4200	4350	4500	4650	4800	4950
D	450	450	450	450	450	450	450	450	450	450	450	450



ARROW STRAIGHT  
«C» TRACK



C 2  
HQ BEARINGS



CARRIAGES CENTER  
HOLES MILLED  
NOT LASERED



MULTI RIVITED  
SECTIONS



JAPANESE ROBOTICS  
FANUC



UNIVERSITY OF  
TECHNOLOGY – BRNO



- 37°C  
TESTED & PROVEN



+ 50°C  
TESTED & PROVEN



MADE IN  
CZECH REPUBLIC

$$B = 0,3 \times A$$

$$L = A + B + (2 \times D) + E$$

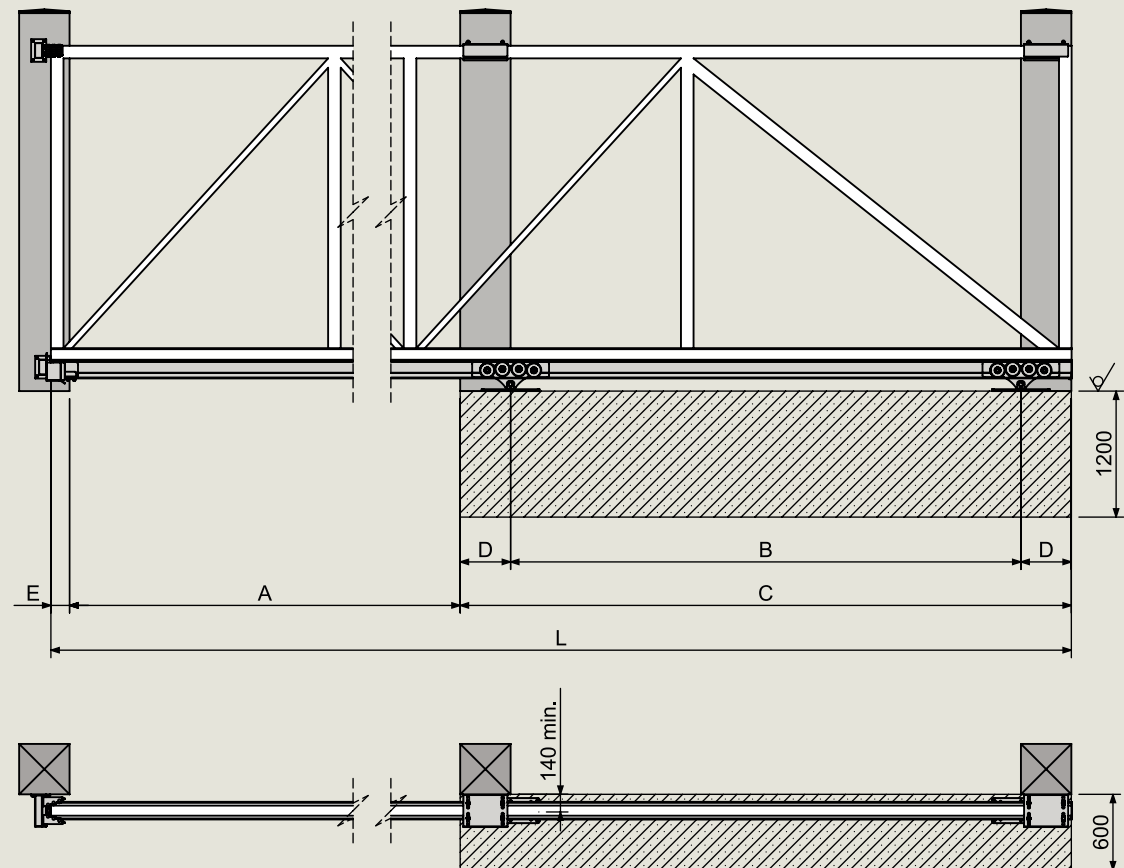
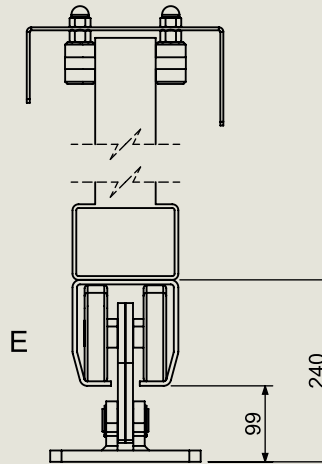

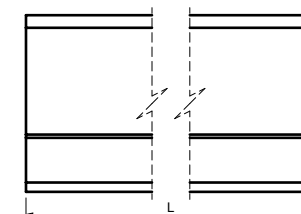
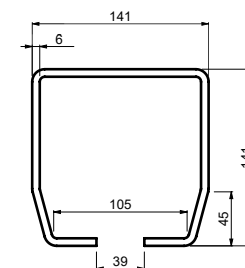
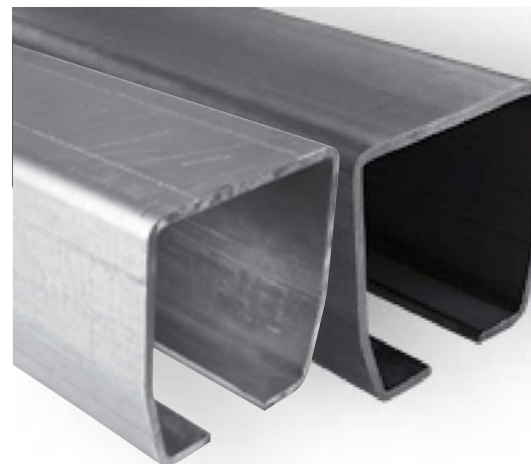
6,00  
mmSPECIAL  
THICKNESS

- (GB) „C“ PROFILE GUIDE FOR CANTILEVER GATE
- (D) „C“ PROFIL FÜR FREITRAGENDE SCHIEBETÖRE
- (F) GUIDE À PROFIL EN « C » POUR PORTAIL AUTOPORTANT
- (E) GUÍA CON PERFIL "C" PARA PUERTA VOLADIZA
- (P) GUIA DE PERFIL "C" PARA PORTÃO CANTILEVER
- (I) GUIDA CON PROFILO A "C" PER CANCELLO AUTOPORTANTE
- (DK) "C" PROFILVANGE TIL FRITTBÆRENDE PORT
- (NL) "C" PROFIEL GELEIDER VOOR VRIJDRAGENDE SCHUIFPOORT
- (N) "C"-PROFILSKINNE FOR FRITTBÆRENDE PORTX
- (S) "C" GEJDPROFIL FÖR FRIBÄRANDE GRIND
- (FIN) "C" -PROFILLIÖHJAIN ULOKEKANNETTEISEEN PORTTIIN
- (PL) SZYNA DO BRAM SAMONOŚNYCH
- (SK) NOSNÝ „C“ PROFIL PRE POSUVNÚ SAMONOSNÚ BRÁNU
- (EE) "C"-PROFILI JUHIK KONSOOLVÄRAVA JAOKS
- (LT) „C“ FORMOS PROFILIUOTAS KREIPTUVAS GEMBINIAMS VARTAMS
- (LV) "C" VEIDA PROFILS KONSOLVEIDA VÄRTIEM

- (CZ) ŠÍNA „C“ PROFIL PRO POSUVNOU SAMONOSNOU BRÁNU
- (RO) GHIDAJ CU PROFIL „C“ PENTRU POARTA AUTOPORTANTĂ ÎN CONSOLĂ
- (HR) VODILICA „C“ PROFILA ZA KLIZNA DVORIŠNA VRATA
- (RUS) НАПРАВЛЯЮЩИЙ РЕЛЬС / ПРОФИЛЬ «С» ДЛЯ ОТКАТНЫХ САМОНЕСУЩИХ ВОРОТ
- (SLO) "C" VODILO ZA SAMONOSNA DRŠNA VRATA
- (TR) KONSOL BAHÇE KAPISI İÇİN "C" PROFIL KIZAĞI
- (AR) للبوابة المدعومة "C" دعامة نظلية جانبية
- (CHN) 悬臂门"C"型导轨
- (MAL) PANDU PROFIL "C" UNTUK PINTU PAGAR JULUR
- (H) C-VEZETŐSÍN TOLÓKAPUHOZ
- (IL) קורה בפרופיל "C" לשער קונסולי
- (BG) "C"-ОБРАЗНА РЕЛСА ЗА КОНЗОЛНА ВРТА
- (KO) 캔틸레버 게이트용 "C"자형 프로파일 가이드
- (SRB) VODICA „C“ PROFILA ZA SAMONOSIVU KAPIJU

Art.	CARRIAGE	SURFACE FINISH	L/1pc	1pc			CODE
			mm	kg	pcs	kg	
STAGE LB 6	SPEED L	UNGALVANIZED	6000	130,2	6	781,2	1700179
STAGE LB 3	SPEED L	UNGALVANIZED	3000	65,1	6	390,6	1700178
STAGE LB 2	SPEED L	UNGALVANIZED	2000	43,4	6	260,4	1700218
STAGE LB 1	SPEED L	UNGALVANIZED	1000	21,7	6	130,2	1720046
STAGE LZ 6	SPEED L	GALVANIZED	6000	130,2	6	781,2	1700180
STAGE LZ 3	SPEED L	GALVANIZED	3000	65,1	6	390,6	1700019
STAGE LZ 2	SPEED L	GALVANIZED	2000	43,4	6	260,4	1700220
STAGE LZ 1	SPEED L	GALVANIZED	1000	21,7	6	130,2	1720052

24  
months24 MONTHS  
TESTED  
& PROVEN- 37°C  
TESTED  
& PROVEN+ 50°C  
TESTED  
& PROVEN



- C 2 HQ BEARINGS
- CARRIAGES CENTER HOLES MILLED NOT LASERED
- MULTI RIVITED SECTIONS
- DOUBLE MONO BLOCK EIGHT WHEELED CARRIAGE

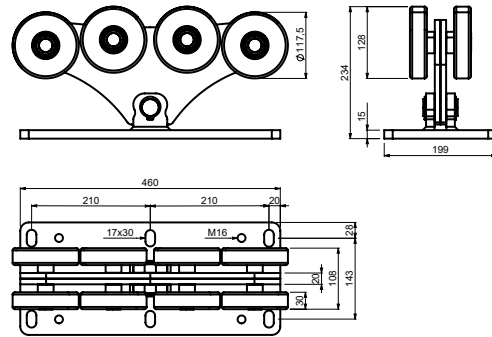

- (GB) EIGHT WHEELED CARRIAGE FOR CANTILEVER GATE
- (D) ROLLAPPARAT MIT ACHT ROLLEN FÜR FREITRAGENDE SCHIEBETORE
- (F) CHARIOT À HUIT ROUES POUR PORTAIL AUTOPORTANT
- (E) CARRIL DE OCHO RUEDAS PARA PUERTA VOLADIZA
- (P) CORREDIÇA DE OITO ROLDANAS PARA PORTÃO CANTILEVER
- (I) CARRELLO A OTTO RUOTE PER CANCELLO AUTOPORTANTE
- (DK) OTTE TRANSPORTHJUL TIL FRITTBÆRENDE PORT ACHTVOUIDI
- (NL) WIELENBLOK VOOR VRIJDRAGENDE SCHUIFPOORT
- (N) ÅTTENHJULS DRIVSKINNE TIL FRITTBÆRENDE PORT
- (S) ÅTTAHJULIG VAGN FÖR FRIBÄRENDE GRIND
- (FIN) KAHDEKSAN PYÖRÄN ALUSTA ULOKEKANNETISEEN PORTTIIN
- (PL) WÓZEK 8-ROLKOWY DO BRAM SAMONOSNYCH
- (SK) VOZÍK OSEMKOLOVÝ PRE POSUVNÚ SAMONOSNÚ BRÁNU
- (EE) KAHEKSARATTALINE SUPORT KONSOOLVÄRAVA JAOKS
- (LT) VEŽIMĖLIS GEMBINIAMS VARTAMS SU AŠTUONIAMS RATUKAIS
- (LV) ASTŅŅU RUĻĻU BLOKS KONSOLVEIDA VĀRTIEM

- (CZ) VOZÍK OSMIKOLOVÝ PRO POSUVNOU SAMONOSNOU BRÁNU
- (RO) CĂRUCIOR PE OPT ROȚI PENTRU POARTA AUTOPORTANTĂ ÎN CONSOLĂ
- (HR) NOSAČ S OSAM KOTAČA ZA KLIZNA DVORIŠNA VRATA
- (RUS) ВОСЬМИКОЛЕШАЯ РОЛИКОВАЯ ТЕЛЕЖКА ДЛЯ ОТКАТНЫХ САМОНЕСУЩИХ ВОРОТ
- (SLO) VOZIČEK Z OSMIMI KOLESI ZA SAMONOSNA DRSNNA VRATA
- (TR) KONSOL BAHÇE KAPISI İÇİN SEKİZ TEKERLEKLİ TAŞIYICI
- (AR) عربة مزودة بثماني عجلات للوابت المدعمة
- (CHN) 悬臂门八轮滑架
- (MAL) PENYORONG LAPAN RODA UNTUK PINTU PAGAR JULUR
- (H) NYOLCGÖRGŐS FUTÓKOCSI TOLÓKAPUHOZ
- (IL) קרונית שמנונה גלגלים לשער קנולתי
- (BG) КОЛИЧКА С ОСЕМ РОЛКИ ЗА КОНЗОЛНА ВРАТА
- (KO) 8개 휠이 있는 캔틸레버 게이트용 이송대
- (SRB) NOSAČ SA OSAM TOČKIČA ZA SAMONOSIVU KAPIJU

Art.	A max. mm	GUIDE	1pc		CODE	
			kg	pc	kg	
SPEED L	13500	STAGE LB/LZ	39,5	1	39,5	1700018



PILOT L



PILOT LN

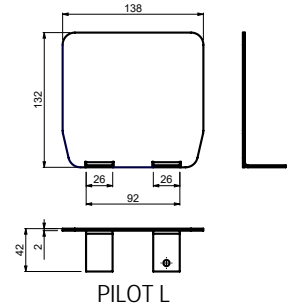

PILOT L

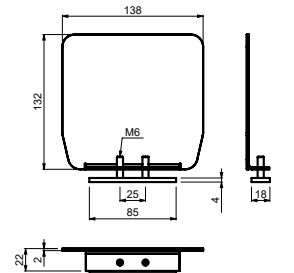

PILOT LN

- (GB) GUIDE END CAP WITHOUT SCREW, DEPENDENT ON SUPPORT WHEEL
- (D) GUIDE END CAP WITH SCREW, INDEPENDENT
- (F) ABSCHLUSSKAPPE FÜR „C“ PROFIL, ABHÄNGIG VON EINLAUFSCUHUH OHNE SCHRAUBE
- (E) CACHE EXTRÊMITE POUR GUIDE SANS VIS, DÉPENDANT DE LA ROUE DE SUPPORT
- (P) CACHE D'EMBOUT DE GUIDE AVEC VIS, INDEPENDANT
- (I) TOPE FINAL DE GUIDA SIN TUERCA, DEPENDIENTE DE LA RUEDA DE SOPORTE
- (RUS) ТОПЕ ФИНАЛ ДЕ ГИДІА СОН ТУЕРСА, ІНДЕПЕНДЕНТЕ
- (SLO) TOPE FINAL DE GUIDA CON TUERCA, INDEPENDIENTE
- (TR) TAMPA FINAL GUIDA SEM PARAFUSO, DEPENDENTE DA ROLDANA DO SUPORTE
- (NL) TAMPA FINAL GUIDA COM PARAFUSO, INDEPENDENTE
- (DK) COPERTURA TERMINALE DELLA GUIDA SENZA VITE, DIPENDENTE DALLA RUOTA DI SOSTEGNO.
- (HR) COPERTURA TERMINALE DELLA GUIDA CON VITE, INDEPENDENTE
- (CZ) WANGENDEHETTE UDEN SKRUE, AFHÆNGIG AF STØTTEHJUL
- (RO) WANGENDEHETTE MED SKRUE, UAFHÆNGIG
- (NL) WANGENDEHETTE MED SKRUE, UAFHÆNGIG
- (SLO) GELEIDER EINDKAP ZONDER SCHROEF, AFHANGIG VAN DRAAGWIEL
- (TR) GELEIDER EINDKAP MET SCHROEF, ONAFHANKELIJK
- (N) ENDEBESLAG TIL SKINNE UTEN SKRUE, FESTES PÅ STØTTEHJUL
- (S) ENDEBESLAG TIL SKINNE MED SKRUE, UAVHÆNGIG
- (FIN) GEJJD SKYDYSKÄPA UTAN SKRUV, BERÖENDE PÅ STÖDHJUL
- (H) GEJJD SKYDYSKÄPA MED SKRUV, ÖBERÖENDE
- (PL) OHAJMIEN PÅÄN KANSI ILMAN RUUVIA, ERILLINEN TUKIPYÖRÄSSÄ
- (SK) OHAJMIEN PÅÄN RUUVILLINEN KANSI, ERILLINEN
- (PL) ZASŁEPKA KOŃCOWA SZYNY BEZ ŚRUBY, ZALEŻNA OD ROLKI NAJZDROWIEJ
- (SK) ZASŁEPKA KOŃCOWA SZYNY ZE ŚRUBĄ, NIEZALEŻNA
- (SRB) ZASLEPKA PRE NOSNÝ „C“ PROFIL, ZÁVISLÁ NA NÁBEHU BEZ SKRUTKY
- (EE) ANEZÁVISLÁ SO SKRUTKU
- (EE) „JUHIKU OTSAKORILMA KRUVITA, SÖLTVALT TUGIRATTAST
- (LT) JUHIKU OTSAKORILMA KRUVIGA, ERALDI“
- (LV) „KREIPTUVO GALINIS DANGTELIS BE SRIEGIO, SUSIETAS SU ATRAMINIU RATUKU
- (LV) KREIPTUVO GALINIS DANGTELIS SU SRIEGIO, ATSKIRAS“
- (LV) „VADOTNES GALA VĀKS BEZ SKRŪVES, ATKARIĢS NO BALSTA RULLIŠA
- (LV) VADOTNES GALA VĀKS AR SKRŪVI, NEATKARIĢS“

- (CZ) ZÁSLEPKA PRO ŠINU „C“ PROFIL, ZÁVISLÁ NA NÁBEHU BEZ ŠROUBU A NEZÁVISLÁ SE ŠROUBEM
- (RO) ACOPERIRE OPRITOR CURSĂ FĂRĂ FILET, ÎN FUNCȚIE DE ROATA DE SUSTINERE
- (HR) OPRITOR CURSĂ ACOPERIRE GHIDAJ CU FILET, INDEPENDENT
- (HR) ČEP VODILICE BEZ VIJKA, OVISNO O NOSIVOM KOTAČU
- (RUS) ČEP VODILICE S VIJKOM, NEOVISAN
- (RUS) ЗАПЛИВКА НАПРАВЛЯЮЩЕГО РЕЛЬСА С «С», ЗАВИСИМАЯ ОТ КОНЦЕВОГО РОЛИКА
- (SLO) BEZ VINITA I NEZAVISIMAJA S VINTOM
- (SLO) ZAKLJUČNI POKROV VODILA BREZ VIJAKA, ODVISEN OD ZAKLJUČNEGA
- (SLO) POKROVA VODILA PODPORNEGA KOLESJA Z VIJAKOM, NEODVISEN
- (TR) VIDASIZ KIZAK UÇ LASTIĞI, DESTEK TEKERLEĞINE BAĞLI
- (AR) VIDALI KIZAK UÇ LASTIĞI, BAĞIMSIZ
- (CHN) 导轨终端盖，无螺栓，依赖于支撑轮
- (MAL) 导轨终端盖，无螺栓，依赖于支撑轮
- (MAL) PENUTUP Hujung Pandu Tanpa Skru, Bergantung Pada Roda Sokongan
- (H) PENUTUP Hujung Pandu Dengan Skru, Bebas
- (H) VEZETŐSÍN LEZÁRÓ-ELEM CSAVAR NÉLKÜL, TÁMASÍTÓGÖRGŐTŐL FÜGG
- (H) VEZETŐSÍN LEZÁRÓ-ELEM CSAVARRAL, FÜGGTLEN
- (IL) מוסך קצה רכס ללא גוף תומך
- (IL) מוסך קצה רכס תלוי על גוף תומך
- (BG) „КРАЙНА КАПКАЧКА ЗА РЕЛСА БЕЗ ВИНТ, ЗАВИСИМА ОТ РОЛКАТА ЗА КОНЗОЛНА РЕЛСА
- (KO) „КРАЙНА КАПКАЧКА ЗА РЕЛСА С ВИНТ, САМОСТОЯТЕЛНА“
- (KO) 나사 없는 가이드 종단 캡, 지지용 휠에 의존
- (SRB) 나사가 있는 가이드 종단 캡, 독립식
- (SRB) ČEP VODICE BEZ ZAVRTNJA, ZAVISAN OD NOSEČEG TOČKIČA
- (SRB) ČEP VODICE SA ZAVRTNEM, NEZAVISAN

Art.	GUIDE	1pc		CODE	
		kg	pcs	kg	
PILOT L	STAGE LB/LZ	0,3	10	3	1700023
PILOT LN	STAGE LB/LZ	0,35	10	3,5	1700024

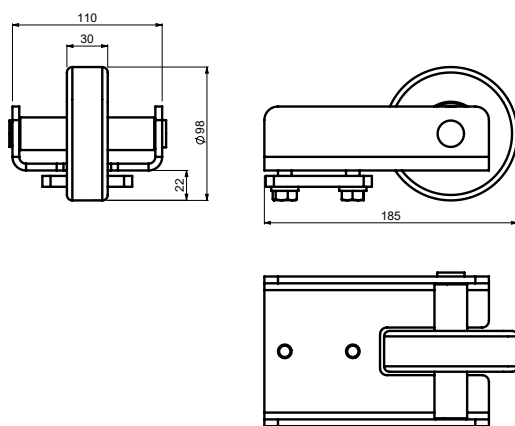
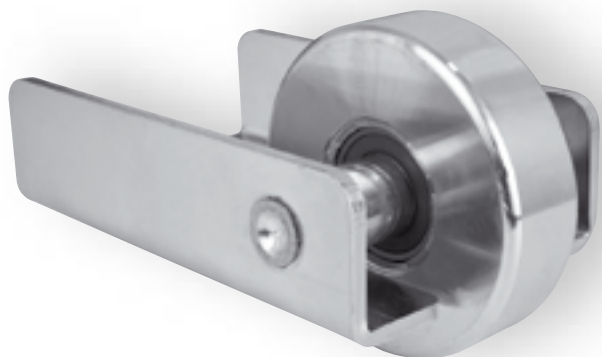

- (GB) GUIDE SUPPORT WHEEL FOR CANTILEVER GATE
- (D) STÜTZRAD FÜR FREITRAGENDE SCHIEBETÖRE
- (F) ROUE DE SUPPORT DE GUIDE POUR PORTAIL AUTOPORTANT
- (E) RUEDA CON SOPORTE DE GUÍA PARA PUERTA VOLADIZA
- (P) ROLDANA DE SUPORTE GUIA PARA PORTÃO CANTILEVER
- (I) RUOTA DI SOSTEGNO DELLA GUIDA PER CANCELLO AUTOPORTANTE
- (DK) VANGESTØTTEHJUL TIL FRITBÆRENDE PORT
- (NL) DRAAGWIEL VOOR GELEIDING VRIJDRAGENDE SCHUIFPOORT
- (N) STYRESKINNE FOR STØTTEHJUL TIL FRITTBÆRENDE PORT
- (S) STÖDHJUL FÖR FRIBÄRANDE GRIND
- (FIN) OHJAIMEN TUKIPYÖRÄ ULÖKEKANNETTEISEEN PORTTIIN
- (PL) ROLKA NAJAZDOWA DO BRAM SAMONOŚNYCH
- (SK) NÁBEH S KLADKOU PRE POSUVNÚ SAMONOSNÚ BRÁNU
- (EE) JUHI TUGIRATAS KONSOOLVÄRAVA JAOKS
- (LT) KREIPTUVO ATRAMOS RATUKAS GEMBINIAMS VARTAMS
- (LV) VADOTNES BALSTA RULLĪTIS KONSOLVEIDA VĀRTIEM

- (CZ) NÁBEH S KLADKOU PRO POSUVNOU SAMONOSNOU BRÁNU
- (RO) ROATĂ DE SUSȚINERE GHIDAJ PENTRU POARTA AUTOPORTANTĂ ÎN CONSOLĂ
- (HR) NOSIVI KOTAČ VODILICE ZA KLIZNA DVORIŠNA VRATA
- (RUS) КОНЦЕВОЙ РОЛИК ДЛЯ ОТКАТНЫХ САМОНЕСУЩИХ ВОРОТ
- (SLO) PODPORNO KOLO VODILA ZA SAMONOSNA DRŠNA VRATA
- (TR) KONSOL BAHÇE KAPISI İÇİN KIZAK DESTEK TEKERLEĞİ
- (AR) عجلة دعمة نذلية للوابية المدعومة
- (CHN) 悬臂门导轨支轮
- (MAL) RODA SOKONGAN PANDU UNTUK PINTU PAGAR JULUR
- (H) VEZETŐ, MEGTÁMASZTÓ GÖRGŐ TOLÓKAPUHOZ
- (IL) גלגל תומך לשער קנדולי
- (BG) РОЛКА ЗА РЕЛСА ЗА КОНЗОЛНА ВРАТА
- (KO) 캔틸레버 게이트용 가이드 지지 휠
- (SRB) NOSEĆI TOČKIĆ VOĐICE ZA SAMONOSIVU KAPIJU

Art.	GUIDE	1pc		CODE
		kg	pcs kg	
RUN L	STAGE LB/LZ	3,23	2 6,46	1700020



- (GB) END STOP FOR CANTILEVER GATE
- (D) EINLAUFSCUH FÜR FREITRAGENDE SCHIEBETÖRE
- (F) BUTÉE POUR PORTAIL AUTOPORTANT
- (E) TOPE FINAL PARA PUERTA VOLADIZA
- (P) BATENTE PARA PORTÃO CANTILEVER
- (I) FERMO DI FINE CORSA PER CANCELLO AUTOPORTANTE
- (DK) ENDESTOP TIL FRITTBÆRENDE PORT
- (NL) EINDSTOP VOOR VRIJDRAGENDE SCHUIFPOO
- (N) ENDESTOPPER FOR FRITTBÆRENDE PORT
- (S) ÄNDSTOPP FÖR FRIBÄRANDE GRIND
- (FIN) PÄÄTYPYSÄYTIN ULÖKEKANNETTEISEEN PORTTIIN
- (PL) ODBOJNIK DO BRAM SAMONOŚNYCH
- (SK) DOJAZDOVÁ KAPSA SPODNÁ PRE POSUVNÚ SAMONOSNÚ BRÁNU
- (EE) OTSALÕPP KONSOOLVÄRAVA JAOKS
- (LT) GALINIS RIBOKLIS GEMBINIAMS VARTAMS
- (LV) GALA AIZTURIS KONSOLVEIDA VĀRTIEM

Art.	GUIDE	1pc		CODE
		kg	pcs kg	
LAST L	STAGE LB/LZ	2,7	2 5,4	1700021

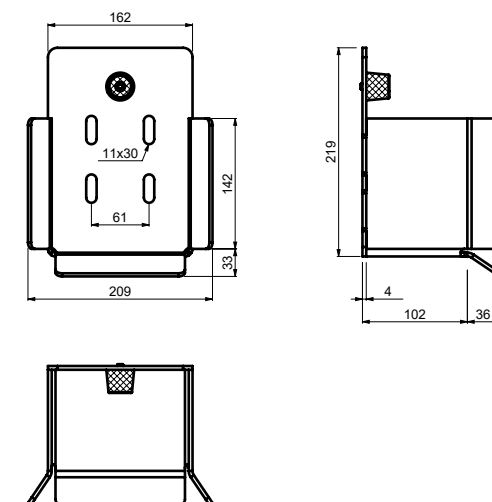

- (CZ) DOJEZDOVÁ KAPSA SPODNÍ PRO POSUVNOU SAMONOSNOU BRÁNU
- (RO) OPRITOR CURSĂ PENTRU POARTA AUTOPORTANTĂ ÎN CONSOLĂ
- (HR) GRANIČNIK ZA KLIZNA DVORIŠNA VRATA
- (RUS) УЛАВЛИВАТЕЛЬ НИЖНИЙ ДЛЯ ОТКАТНЫХ САМОНЕСУЩИХ ВОРОТ
- (SLO) ZAUSTAVLJALNIK ZA SAMONOSNA DRŠNA VRATA
- (TR) KONSOL BAHÇE KAPISI İÇİN UÇ TESPİT PARÇASI
- (AR) الحاجز الطرفي للوابية المدعومة
- (CHN) 悬臂门终点挡块
- (MAL) PENYENDAL HUJUNG UNTUK PINTU PAGAR JULUR
- (H) ÚTKÖZŐ TOLÓKAPUHOZ
- (IL) מקבל קצה לשער קנדולי
- (BG) СТОПЕР ЗА КОНЗОЛНА ВРАТА
- (KO) 캔틸레버 게이트용 종단 장치대
- (SRB) GRANIČNIK ZA SAMONOSIVU KAPIJU

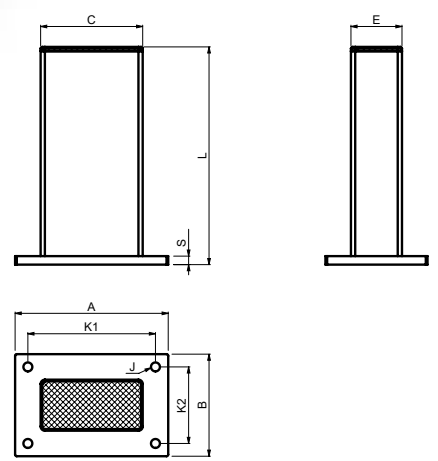

- (GB) END STOP BRACKET
- (D) KONSOLE FÜR EINLAUFSCHUH
- (F) ÉTRIER POUR BUTÉE
- (E) SOPORTE DE TOPE FINAL
- (P) SUPORTE DE BATENTE
- (I) STAFFA PER FERMO DI FINE CORSA
- (DK) ENDESTOP BESLAG
- (NL) EINDSTOP BEVESTIGINGSBEUGEL
- (N) STOPPEBRACKET
- (S) ÄNDSTOPP KONSOL
- (FIN) PÄÄTYPYSÄYTTIMEN KANNATIN
- (PL) WSPORNIK ODBOJNIKA
- (SK) KONZOLA PRE DOJAZDOVÚ KAPSU
- (EE) OTSALÕPU KLAMBER
- (LT) GALINIO RIBOKLIO GEMBĖ
- (LV) GALA AIZTURA KRONŠTEINS

- (CZ) KONZOLA PRO DOJEZDOVU KAPSU
- (RO) OPRITOR CURSĂ CONSOLĂ
- (HR) KONZOLA GRANIČNIKA
- (RUS) КРОНШТЕЙН УЛАВЛИВАТЕЛЯ
- (SLO) OPORNIK ZAUSTAVLJALNIKA
- (TR) UÇ TESPİT PARÇASI DİRSEĞİ
- (AR) سنادة المانع الطرفي
- (CHN) 终点挡块支座
- (MAL) PENDAKAP PENYENDAL HUJUNG
- (H) ÚTKÖZŐ-KERET
- (IL) עמודון למעצור קצה
- (BG) СКОБА ЗА СТОПЕР
- (KO) 종단 정지대 브래킷
- (SRB) KONZOLA GRANIČNIKA

Art.	L	A	B	C	E	J	K1	K2	S	END STOP	1pc			CODE
											kg	pcs	kg	
											mm			
											Ø			
											mm			
PARK L	260	180	120	120	60	10,5	150	90	10	LAST/PADDOCK	4,31	2	8,62	1700022
PARK L 350	355	180	120	120	60	10,5	150	90	10	LAST/PADDOCK	5,25	2	10,5	1700197

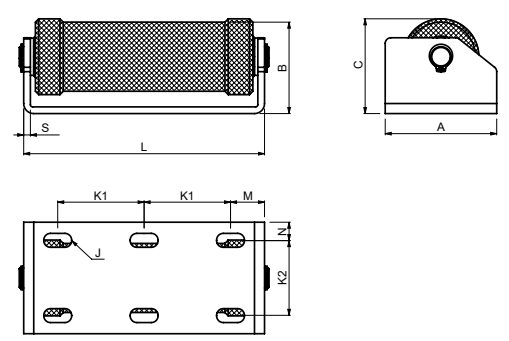

- (GB) SUPPORT ROLLER FOR CANTILEVER GATE
- (D) STÜTZROLLE FÜR AUSLEGERTOR
- (F) ROULEAU DE SUPPORT POUR PORTAIL COULISSANT AUTOPORTANT
- (E) RODILLO DE SOPORTE PARA PORTÓN EN VOLADIZO
- (P) ROLO DE SUPORTE PARA PORTÃO DE CANTILEVER
- (I) RULLO DI SOSTEGNO PER CANCELLO AUTOPORTANTE
- (DK) STØTTERULLE TIL FRITBÆRENDE PORT
- (NL) STEUNROL VOOR SCHUIFPOORT
- (N) STØTTERULLE FOR RULLEPORT
- (S) STÖDRULLE FÖR FRIBÄRANDE GRIND
- (FIN) TUKIRULLA ULOKEPORTTIIN
- (PL) ROLKA DOLNA DO BRAMY SAMONOŠNEJ
- (SK) PODPORNÝ VALEC PRE SAMONOSNÉ BRÁNY
- (EE) TUGIRULLIK KONSOOLVÁRAVA JAOKS
- (LT) ATRAMINIS RITINĖLIS GEMBINIAMS VARTAMS
- (LV) BALSTA RULLĪTIS KONSOLVEIDA VĀRTIEM

- (CZ) KONZOLA S KLADKOU PRO PODPĚRU POSUVNÉ SAMONOSNÉ BRÁNY
- (RO) ROLĂ DE SUSȚINERE PENTRU POARTA ÎN CONSOLĂ
- (HR) POTPORNJI VALJAK ZA NOSIVA VRATA
- (RUS) ОПОРНЫЙ РОЛИК ДЛЯ САМОНЕСУЩИХ ВОРОТ
- (SLO) PODPORNÍ VALJ ZA SAMONOSNA DRSNÁ VRATA
- (TR) MANİVELA KAPİ İÇİN DESTEK MAKARASI
- (AR) اسطوانة الدعم لوابية الكابول
- (CHN) 懸臂門支撐棍
- (MAL) PENGELEK SOKONGAN UNTUK GET JULUR
- (H) TARTÓGÖRGŐ TOLÓKAPUHOZ
- (IL) גלגל תומך לשער קנדולי
- (BG) ПОДДЪРЖАЩА РОЛКА ЗА КОНЗОЛНА ВРАТА
- (KO) 캔틸레버 게이트용 지지 롤러
- (SRB) NOSEČI VALJAK ZA SAMONOSIVU KAPIJU

Art.	L	A	B	C	J	K1	K2	M	N	S	1pc			CODE
											kg	pcs	kg	
											mm			
											kg			
DRIVESHAFT 150	216	100	82	85	13x25	77	66	31	17	6	2,52	2	5,04	1700334

DESIGNED FOR STRAIGHT ROLLING MOVEMENT



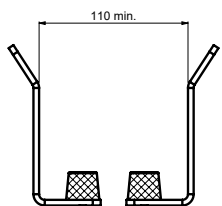
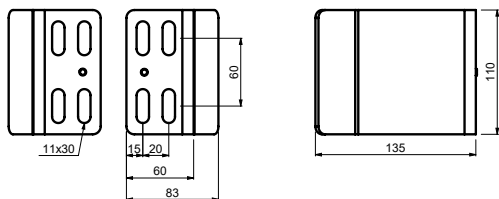

- (GB) END STOP
- (D) ENDANSCHLAG
- (F) BUTÉE
- (E) TOPE FINAL
- (P) FIM DE CORSO
- (I) ARRESTO TERMINALE
- (DK) ENDESTOP
- (NL) EINDSTOP
- (N) ENDESTOPP
- (S) ÄNDSTOPP
- (FIN) RAJOITIN
- (PL) ZDERZAK KRAŃCOWY
- (SK) DORAZ
- (EE) OTSA LÕPP
- (LT) GALINIS RIBOKLIS
- (LV) GALA AIZTURIS

- (CZ) KONCOVÝ DORAZ
- (RO) OPRITOR FINAL
- (HR) GRANIČNIK
- (RUS) КОНЦЕВОЙ УПОР
- (SLO) KONČNI ELEMENT
- (TR) UÇ TIPASI
- (AR) نقطة التوقف
- (CHN) 限位挡块
- (MAL) ADANG Hujung
- (H) VÉGÜTKÖZŐ
- (IL) מקבל מתכוון עם מעגור גומי
- (BG) СТОПЕР
- (KO) 종단 장치대
- (SRB) GRANIČNIK

Art.	BRACKET	1pc			CODE
		kg	pcs	kg	
PADDOCK L	PARK L/PARK L 350	1,54	2	3,08	1700195

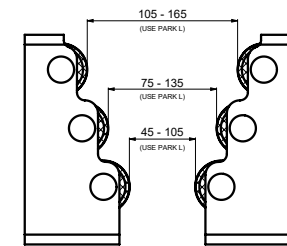
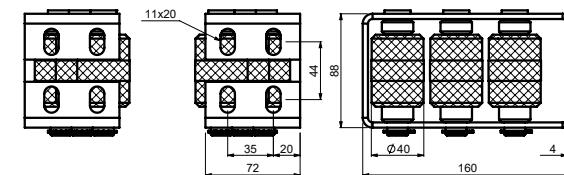

- (GB) END STOP WITH ROLLER
- (D) ENDANSCHLAG MIT ROLLE
- (F) BUTÉE AVEC ROULEAU
- (E) TOPE FINAL CON RODILLO
- (P) FIM DE CORSO COM ROLO
- (I) ARRESTO TERMINALE CON RULLO
- (DK) ENDESTOP MED VALSE
- (NL) EINDSTOP MET ROLLEN
- (N) ENDESTOPP MED RULLE
- (S) ÄNDSTOPP MED RULLE
- (FIN) RAJOITIN RULLALLA
- (PL) ZDERZAK KRAŃCOWY Z ROLKĄ
- (SK) DORAZ S VALČEKOM
- (EE) OTSALÕPP RULLIKUGA
- (LT) GALINIS RIBOKLIS SU RITINĖLIU
- (LV) GALA AIZTURIS AR RULLĪTI

- (CZ) KONCOVÝ DORAZ S KLDKOU
- (RO) OPRITOR FINAL CU ROLĂ
- (HR) GRANIČNIK S VALJKOM
- (RUS) КОНЦЕВОЙ УПОР С РОЛИКОМ
- (SLO) KONČNI ELEMENT S KOLESCEM
- (TR) MAKARALI UÇ TIPASI
- (AR) نقطة التوقف المزودة بكرة
- (CHN) 帶轆子的限位挡块
- (MAL) ADANG Hujung DENGAN PENGGELEK
- (H) VÉGÜTKÖZŐ GÖRGÖVEL
- (IL) מקבל מתכוון עם גלגלי אוקולין
- (BG) СТОПЕР С РОЛИКА
- (KO) 롤러가 있는 종단 장치대
- (SRB) GRANIČNIK SA VALJKOM



Art.	BRACKET	1pc			CODE
		kg	pc	kg	
PADDOCK 6	PARK L/PARK L 350	3,12	1	3,12	1700192

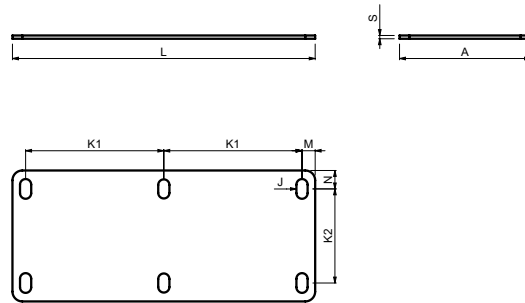

- (GB) WASHER FOR CANTILEVER CARRIAGE
- (D) UNTERLEGSCHLEIBE FÜR AUSLEGERSCHLITTEN
- (F) RONDELLE POUR CHARIOT CANTILEVER
- (E) TUERCA PARA CARRO EN VOLADIZO
- (P) ARRUELA PARA TRANSPORTE DE CANTILEVER
- (I) RONDELLA PER CARRELLO CANCELLO AUTOPORTANTE
- (DK) SKIVE TIL FRITBÆRENDE PORT
- (NL) RING VOOR SCHUIFWAGEN
- (N) SKIVE FOR RULLEPORTVOGN
- (S) BRICKA FÖR FRIBÄRANDE GRINDVAGN
- (FIN) ALUSLEVY ULOKETELINEESEEN
- (PL) PODKLADKA DO WÓZKA BRAMY SAMONOŚNEJ
- (SK) PODLOŽKA PRE SAMONOSNÝ NOSNÍK
- (EE) SEIB KONSOOLALUSE JAOKS
- (LT) POVERŽLĖ GEMBINIŲ VARTŲ VEŽIMĖLIUI
- (LV) PĀPLĀKSNE KONSOLĒS NESOŠĀJAM RUĻĻU BLOKAM

- (CZ) PODLOŽKA PRO VOZÍK
- (RO) ȘAIBĂ PENTRU SISTEMUL DE CULISARE ÎN CONSOLĂ
- (HR) PODLOŠKA ZA NOSIVO PODVOZJE
- (RUS) ШАЙБА ДЛЯ РОЛИКОВЫХ ТЕЛЕЖЕК САМОНЕСУЩИХ ВОРОТ
- (SLO) PODLOŽKA ZA VOZIČEK
- (TR) MANIVELA TAŞIYICISI İÇİN RONDELA
- (AR) حلقة لتثبيت لواء الكابول
- (CHN) 悬臂架垫片
- (MAL) SESENDAL UNTUK PEMBAWA JULUR
- (H) ALÁTÉT TOLÓKAPU FUTÓKOSIHOZ
- (IL) הקוטר לשער קרוזולי
- (BG) ВЛОЖКА ЗА КОНЗОЛНА КОЛИЧКА
- (KO) 캔틸레버 이송대용 와셔
- (SRB) PODLOŠKA ZA SAMONOSIVU KAPIJU

Art.	L	A	J	K1	K2	M	N	S	CARRIAGE	1pc	CODE		
										kg	pcs	kg	
											mm		
RAMP L 3	460	199	17x30	210	143	20	28	3	SPEED L	2,14	2	4,28	1700301
RAMP L 5	460	199	17x30	210	143	20	28	5	SPEED L	3,42	2	6,84	1700302
RAMP L 8	460	199	17x30	210	143	20	28	8	SPEED L	5,56	2	11,12	1700303

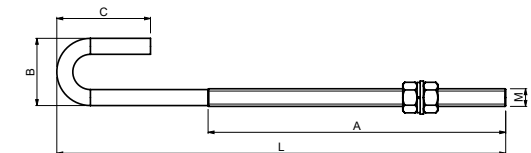

- (GB) FIXING BAR FOR CANTILEVER CARRIAGE
- (D) BEFESTIGUNGSSTANGE FÜR AUSLEGERSCHLITTEN
- (F) BARRE DE FIXATION POUR CHARIOT CANTILEVER
- (E) BARRA DE FIJACIÓN PARA CARRO EN VOLADIZO
- (P) BARRA DE FIXAÇÃO DE TRANSPORTE DE CANTILEVER
- (I) BARRA DI FISSAGGIO PER CARRELLO CANCELLO AUTOPORTANTE
- (DK) FASTGØRELSSESSTANG TIL FRITBÆRENDE PORT
- (NL) BEVESTIGINGSBALK VOOR SCHUIFWAGEN
- (N) FESTESTANG FOR RULLEPORT
- (S) FÄSTBALK FÖR FRIBÄRANDE GRINDVAGN
- (FIN) KIINNITYSPALKKI ULOKETELINEESEEN
- (PL) LISTWA MOCUJĄCA DO WÓZKA BRAMY SAMONOŚNEJ
- (SK) UPEVNŔOVACIA TYČ PRE SAMONOSNÝ NOSNÍK
- (EE) FIKSEERIMISTALA KONSOOLALUSE JAOKS
- (LT) TVIRTINIMO STRYPAS GEMBINIŲ VARTŲ VEŽIMĖLIUI
- (LV) FIKSĒJOŠAIS STIENIS KONSOLĒS NESOŠĀJAM RUĻĻU BLOKAM

- (CZ) FIXAČNÍ TYČ PRO VOZÍK
- (RO) BARĂ DE FIXARE PENTRU SISTEMUL DE CULISARE ÎN CONSOLĂ
- (HR) FIKSIRAJUĆA ŠIPKA ZA NOSIVO PODVOZJE
- (RUS) КРЕПЕЖНЫЙ СТЕРЖЕНЬ ДЛЯ РОЛИКОВЫХ ТЕЛЕЖЕК САМОНЕСУЩИХ ВОРОТ
- (SLO) PRITRDILNI DROG ZA VOZIČEK
- (TR) MANIVELA TAŞIYICISI İÇİN SABITLEME ÇUBUĞU
- (AR) قضيب تثبيت لواء الكابول
- (CHN) 悬臂架固定条
- (MAL) BAR IKATAN UNTUK PEMBAWA JULUR
- (H) RÖGZÍTŐRÚD TOLÓKAPU FUTÓKOSIHOZ
- (IL) מוט קיבוע לגגלים לקרוזולי
- (BG) ФИКСАТОР ЗА КОНЗОЛНА КОЛИЧКА
- (KO) 캔틸레버 이송대용 고정대
- (SRB) FIKSIRAJUĆA ŠIPKA ZA SAMONOSIVU KAPIJU

Art.	L	A	B	C	M	WASHER	1pc	CODE		
							kg	pcs	kg	
								mm		
CLINCH 16	410	300	60	80	M16	RAMP	0,72	12	8,64	1700239

“THE BEST WAY  
TO PREDICT THE FUTURE  
IS TO CREATE IT”

– Abraham Lincoln



RESEARCH & DEVELOPMENT  
CAIS PARTNER



SLIDING GATE HARDWARE

SLIDING GATE  CAIS

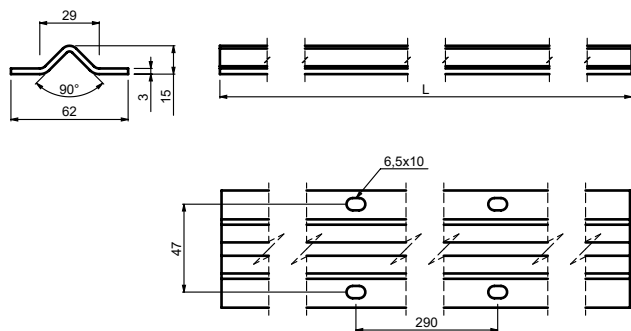

- (GB) „V“ PROFILE GUIDE, FIXED, FOR SLIDING GATES AND DOORS  
 (D) „V“ PROFIL FÜR SCHIEBETÖRE ZUM SCHRAUBEN  
 (F) GUIDE PROFILÉ EN «V», FIXÉ, POUR PORTAILS ET PORTES COULISSANTS  
 (E) GUÍA CON PERFIL «V» Fija, PARA PORTONES Y PUERTAS CORREDERAS  
 (P) GUIA DE PERFIL EM «V», FIXO, PARA PORTÕES E PORTAS DESLIZANTES  
 (I) GUIDA CON PROFILO A «V», FISSA, PER CANCELLI E PORTE SCORREVOLI  
 (DK) „V“ PROFILVANGE, FAST, FOR SKYDEPORTE OG DØRE  
 (NL) „V“ PROFIEL GELEIDER, VASTGESCHROEFD, VOOR SCHUIFPOORTEN EN DEUREN  
 (N) „V“-PROFILSKINNE, FAST, FOR SKYVEPORTER OG DØRER  
 (S) „V“ GEJDPROFIL, FAST, FÖR SKJUTBARA GRINDAR OCH DÖRRAR  
 (FIN) „V“-PROFILINEN OHJAIN, PYSYVÄ, LIUKUPORTTEIHIN JA -OVIIN  
 (PL) SZYNA O PROFILU „V“, PRZYKREŚCANA, DO BRAM I DRZWI PRZESUWNYCH  
 (SK) KOLAJNICA „V“ PROFIL PRE POSUVNŮ BRÁNU A DVĚRE, K PRISKRUTKOVANIU  
 (EE) „V“-PROFILI JUHIK, FIKSEERITUD, LIUGVÄRVATE JA -USTE JAAKS  
 (LT) „V“ FORMOS PROFILIUOTAS KREIPTUVAS, FIKSUOTAS, ŠTUMDOMIESIEMS VARTAMS IR DURIMS  
 (LV) „V“ VEIDA PROFILS, FIKSĒTS, BĪDĀMAJEM VĀRTIEM UN DURVĪM

- (CZ) ŠÍNA „V“ PROFIL PRO POSUVNOU BRÁNU A VRATA, K PŘIŠROBOVÁNÍ  
 (RO) PROFIL DE GHIDAJ „V“, FIX, PENTRU PORȚILE ȘI UȘILE GLISANTE  
 (HR) VODILICA „V“ PROFILA, UGRADNJA ZAVRTNJIMA, ZA KLIZNA DVORIŠNA I KUĆNA VRATA  
 (RUS) МОНОРЕЛЬС / ПРОФИЛЬ «V» ДЛЯ ОТКАТНЫХ ВОРОТ, ПРИКРУЧИВАНИЕ ВИНТАМИ  
 (SLO) „V“ VODILO, FIKSNO, ZA DRŠNA VRATA  
 (TR) SÜRGÜLÜ BAĞÇE KAPILARI VE KAPILAR İÇİN „V“ PROFIL KIZAĞI, SABİT  
 (AR) دعامة بليقة جانبية «V» ثابتة البوابات والأبواب المنزلقة  
 (CHN) 滑动门固定式“V”型导轨  
 (MAL) PANDU PROFIL „V“, TETAP, UNTUK PINTU PAGAR DAN PINTU GELONGSOR  
 (H) V-VEZETŐSÍN, RÖGZÍTETT, TOLÓAJTÓKHOZ ÉS KARUKHOZ  
 (IL) מסילת הניידות לשיער הזזה חתונה בעיגון  
 (BG) „V“-ОБРАЗЕН ПРОФИЛ, ФИКСИРАН, ЗА ПЛЪЗГАЩИ ПОРТИ И ВРАТИ  
 (KO) „V“자형 프로파일 가이드, 고정식, 슬라이딩 게이트 및 도어용  
 (SRL) VODICA „V“ PROFILA, UGRADNJA ZAVRTNJIMA, ZA KLIZNE KAPIJE I VRATA

Art.	SURFACE FINISH	L/1pc	1pc			CODE
		mm	kg	pcs	kg	
TRAIL 6	GALVANIZED	6000	9,9	20	198	1700161
TRAIL 4	GALVANIZED	4000	6,6	20	132	1720055
TRAIL 3	GALVANIZED	3000	4,95	20	99	1700203
TRAIL 2	GALVANIZED	2000	3,3	20	66	1720057
TRAIL 1	GALVANIZED	1000	1,65	20	33	1720058

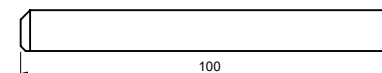

- (GB) FIXING PIN FOR PROFILE GUIDE  
 (D) FIXIERSTIFT FÜR PROFILFÜHRUNG  
 (F) GOUPILLE DE FIXATION POUR GUIDE DE PROFIL  
 (E) PERNO DE FIJACIÓN PARA GUÍA DE PERFIL  
 (P) PINO DE FIXAÇÃO PARA O GUIA DE PERFIL  
 (I) PERNO DI FISSAGGIO PER GUIDA PROFILATA  
 (DK) FASTGØRELSSESTIFT TIL PROFILVANGE  
 (NL) BEVESTIGINGSPLAAT VOOR PROFIELGELEIDER  
 (N) FESTEPIINNE FOR PROFILSTYRING  
 (S) FIXERINGSSTIFT FÖR GEJDPROFIL  
 (FIN) KIINNITYSTAPPI PROFILIOHJAJIMEEN  
 (PL) BOLEC USTALAJĄCY DO SZYNY  
 (SK) UPEVŇOVACÍ KOLÍK PRE VEDENIE PROFILU  
 (EE) FIKSEERIMISTIV PROFILIJUHIKU JAAKS  
 (LT) PROFILIUOTO KREIPTUVO TVIRTINIMO KAIŠTIS  
 (LV) FIKSĒJŠĀ TAPA PROFILAM

- (CZ) FIXAČNÍ KOLÍK PRO PROFIL  
 (RO) PIVOT DE FIXARE PENTRU PROFILUL DE GHIDAJ  
 (HR) FIKSIRAJUĆI KLIN ZA PROFILNU VODILICU  
 (RUS) КРЕПЕЖНЫЙ ШТИФТ ДЛЯ НАПРАВЛЯЮЩЕГО РЕЛЬСА ПРОФИЛЯ  
 (SLO) PRITRDILNI ZATIČ ZA PROFILIRANO VODILO  
 (TR) PROFIL YATAĞI İÇİN SABİTLEME PİMİ  
 (AR) مسمار التثبيت لموجه القطار  
 (CHN) 型材导向装置固定销  
 (MAL) PIN IKATAN UNTUK PANDUAN PROFIL  
 (H) RÖGZÍTŐCSAP VEZETŐSÍNHEZ  
 (IL) פין קיבוע לפרופיל מוביל  
 (BG) ФИКСИРАЩ БОЛТ ЗА РЕЛСА  
 (KO) 프로파일 가이드용 고정 핀  
 (SRL) FIKSIRAJUĆI KLIN ZA PROFIL VODICE

Art.	GUIDE	1pc			CODE
		kg	pcs	kg	
PIN TRAIL	TRAIL	0,08	10	0,8	1700346

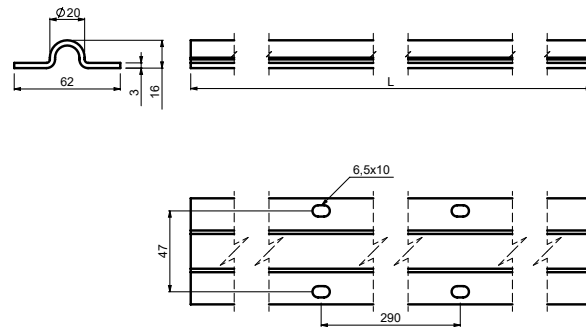

- (GB) 0° PROFILE GUIDE, FIXED, FOR SLIDING GATES AND DOORS  
 (D) 0° PROFIL FÜR SCHIEBETÖRE ZUM SCHRAUBEN  
 (F) GUIDE PROFILÉ EN « O », FIXÉ, POUR PORTAILS ET PORTES COULISSANTS  
 (E) GUÍA CON PERFIL « O » FIJA, PARA PORTONES Y PUERTAS CORREDERAS  
 (P) GUIA DE PERFIL EM « O », FIXO, PARA PORTÕES E PORTAS DESLIZANTES  
 (I) GUIDA CON PROFILO A « O », FISSA, PER CANCELLI E PORTE SCORREVOLI  
 (DK) 0° PROFILVANGE, FAST, FOR SKYDEPORTE OG DØRE  
 (NL) 0° PROFIEL GELEIDER, VASTGESCHROEFD, VOOR SCHUIFPOORTEN EN DEUREN  
 (N) 0°-PROFILSKINNE, FAST, FOR SKYVEPORTER OG -DØRER  
 (S) 0° GEJDPROFIL, FAST, FÖR SKJUTBARA GRINDAR OCH DÖRRAR  
 (FIN) 0°-PROFILLINEN OHJAIN, PYSYVÄ, LIUKUOPORTEIHIN JA -OVIIN  
 (PL) SZYNA O PROFILU, 0°, PRZYKREŚCANA, DO BRAM I DRZWI PRZESUWNYCH  
 (SK) KOLAJNICA, 0° PROFIL PRE POSUVNÚ BRÁNU A DVERE, K PRISKRUTKOVANIU  
 (EE) 0°-PROFILLI JUHIK, FIKSEERITUD, LIUGVÄRIVATE JA -USTE JAOKS  
 (LT) 0° FORMOS PROFILIUOTAS KREIPTUVAS, FIKSUOTAS, STUMDOMIESIEMS VARTAMS IR DURIMS  
 (LV) 0° VEIDA PROFILS, FIKSĒTS, BĪDĀMAJEM VĀRTIEM UN DURVĪM

- (CZ) ŠINA, 0° PROFIL PRO POSUVNOU BRÁNU A VRATA, K PŘÍŠROBOVÁNÍ  
 (RO) PROFIL DE GHIDAJ, 0°, FIX, PENTRU PORȚILE ȘI UȘILE GLISANTE  
 (HR) VODILICA, 0° PROFILA, UGRADNJA ZAVRTNJIMA, ZA KLIZNA DVORIŠNA I KUĆNA VRATA  
 (RUS) МОНОРЕЛЬС / ПРОФИЛЬ «О» ДЛЯ ОТКАТНЫХ ВОРОТ, ПРИКРУЧИВАНИЕ ВИНТАМИ  
 (SLO) 0° VODILO, FIKSNO, ZA DRŠNA VRATA  
 (TR) SÜRGÜLÜ BAHÇE KAPILARI VE KAPILAR İÇİN 0° PROFIL KIZAĞI, SABIT  
 (AR) دعامة نظلية جاذبية 0° قابلة للثوابت والأبواب المنزلقة  
 (CHN) 滑动门固定式 0° 型导轨  
 (MAL) PANDU PROFIL 0°, TETAP, UNTUK PINTU PAGAR DAN PINTU GELONGSOR  
 (H) 0-VEZETŐSÍN, RÖGZÍTETT, TOLÓAJTÓKHOZ ÉS KAPUKHOZ  
 (IL) לשע"ר תמיכה תלת-ממדית בעומק 0 מ"מ  
 (BG) 0°-ОБРАЗЕН ПРОФИЛ, ФИКСИРАН, ЗА ПЛЪЗГАЩИ ПОРТИ И ВРАТИ  
 (KO) 0° 자형 프로필 가이드, 고정식, 슬라이딩 게이트 및 도어용  
 (SRL) VODICA, 0° PROFILA, UGRADNJA ZAVRTNJIMA, ZA KLIZNE KAPJIE I VRATA

Art.	SURFACE FINISH	L/1pc	1pc			CODE
		mm	kg	pcs	kg	
ROAD 6	GALVANIZED	6000	10,62	20	212,4	1700162
ROAD 4	GALVANIZED	4000	7,08	20	141,6	1720061
ROAD 3	GALVANIZED	3000	5,31	20	106,2	1700204
ROAD 2	GALVANIZED	2000	3,54	20	70,8	1720063
ROAD 1	GALVANIZED	1000	1,77	20	35,4	1720064

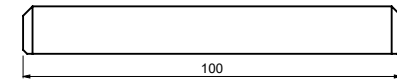

- (GB) FIXING PIN FOR PROFILE GUIDE  
 (D) FIXIERSTIFT FÜR PROFILFÜHRUNG  
 (F) GOUPILLE DE FIXATION POUR GUIDE DE PROFIL  
 (E) PERNO DE FIJACIÓN PARA GUÍA DE PERFIL  
 (P) PINO DE FIXAÇÃO PARA O GUIA DE PERFIL  
 (I) PERNO DI FISSAGGIO PER GUIDA PROFILATA  
 (DK) FASTGØRELSESSTIFT TIL PROFILVANGE  
 (NL) BEVESTIGINGSPLAAT VOOR PROFIELGELEIDER  
 (N) FESTE PINNE FOR PROFILSTYRING  
 (S) FIXERINGSTIFT FÖR GEJDPROFIL  
 (FIN) KIINNITYSTAPPI PROFILIOHJAJMEEN  
 (PL) BOLEC USTALAJĄCY DO SZYNY  
 (SK) UPEVNŔOVACÍ KOLÍK PRE VEDENIE PROFILU  
 (EE) FIKSEERIMISTIVH PROFILIJUHIKU JAOKS  
 (LT) PROFILIUOTO KREIPTUVO TVIRTINIMO KAIŠTIS  
 (LV) FIKSEJŠOŠĀ TAPA PROFILAM

- (CZ) FIXAČNÍ KOLÍK PRO PROFIL  
 (RO) PIVOT DE FIXARE PENTRU PROFILUL DE GHIDAJ  
 (HR) FIKSIRAJUĆI KLIN ZA PROFILNU VODILICU  
 (RUS) КРЕПЕЖНЫЙ ШТИФТ ДЛЯ НАПРАВЛЯЮЩЕГО РЕЛЬСА ПРОФИЛЯ  
 (SLO) PRITRDILNI ZATIČ ZA PROFILIRANO VODILO  
 (TR) PROFIL YATAĞI İÇİN SABITLEMELİ PİMİ  
 (DK) سمسار الثبيت لموجه القناع  
 (AR) سمسار الثبيت لموجه القناع  
 (CHN) 型材导向装置固定销  
 (MAL) PIN IKATAN UNTUK PANDUAN PROFIL  
 (H) RÖGZÍTŐCSAP VEZETŐSÍNHEZ  
 (IL) פין קיבוע לפרופיל מוביל  
 (BG) ФИКСИРАЩ БОЛТ ЗА РЕЛСА  
 (KO) 프로필 가이드용 고정 핀  
 (SRL) FIKSIRAJUĆI KLIN ZA PROFIL VODICE

Art.	GUIDE	1pc			CODE
		kg	pcs	kg	
PIN ROAD	ROAD	0,11	10	1,1	1700347

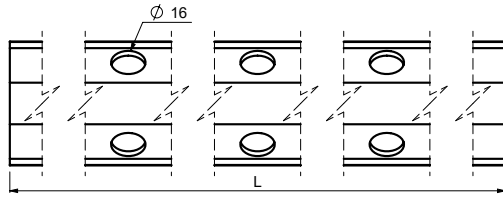
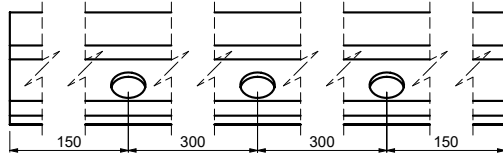
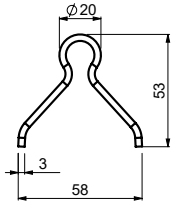

- (GB) „O“ PROFILE GUIDE, CONCRETED, FOR SLIDING GATES AND DOORS  
 (D) „O“ PROFIL FÜR SCHIEBETORE ZUM BETONIEREN  
 (F) GUIDE PROFILÉ EN « O », BÉTONNÉ, POUR PORTAILS ET PORTES COULISSANTS  
 (E) GUÍA CON PERFIL "O" ENCOFRADA, PARA PORTONES Y PUERTAS CORREDERAS  
 (P) GUIA DE PERFIL EM "O", CONCRETADO, PARA PORTÕES E PORTAS DESLIZANTES  
 (I) GUIDA CON PROFILO A "O", CEMENTATA, PER CANCELLI E PORTA SCORREVOLI  
 (DK) "O" PROFILVANGE, STØBT I BETON, FOR SKYDEPORTE OG DØRE  
 (NL) "O" PROFIEL GELEIDER, GESTORT IN BETON, VOOR SCHUIFFOORTEN EN DEUREN  
 (N) "O"-PROFILSKINNE, BETONGFESTET, FOR SKYVEPORTER OG -DØRER  
 (S) "O" GEJDPROFIL, CEMENTERAD, FÖR SKJUTBARA GRINDAR OCH DÖRRAR  
 (FIN) "O"-PROFILILINEN OHJAIN, BETONINEN, LIUKUPORTTEIHIN JA -OVIIN  
 (PL) SZYNA O PROFILU „O“, ZALEWANA W BETONIE, DO BRAM I DRZWI PRZESUWNYCH  
 (SK) KOLAJNICA „O“ PROFIL PRE POSUVNÚ BRÁNU A DVĚRE, K ZABETÓNOVANIU  
 (EE) "O"-PROFILILI JUHIK, BETONISEERITUD, LIUGVÁRIVATE JA -USTE JAOKS  
 (LT) „O“ FORMOS PROFILIUOTAS KREIPTUVAS, BETONUOTAS, STUMDOMIESIEMS VARTAMS IR DURIMS  
 (LV) "O" VEIDA PROFILS, BETONĒTS, BĪDĀMAJĒM VĀRTIEM UN DURVĪM

- (CZ) ŠÍNA „O“ PROFIL PRO POSUVNOU BRÁNU A VRATA, K ZABETONOVÁNÍ  
 (RO) PROFIL DE GHIDAJ „O“, CIMENTAT, PENTRU PORȚILE ȘI UȘILE GLISANTE  
 (HR) VODILICA „O“ PROFILA, UGRADNJA BETONIRANJEM, ZA KLIZNA DVORIŠNA I KUĆNA VRATA  
 (RUS) МОНОРЕЛЬС / ПРОФИЛЬ «О» ДЛЯ ОТКАТНЫХ ВОРОТ, ЦЕМЕНТИРОВАНИЕ  
 (SLO) "O" VODILO, ZA PRITRDITEV Z BETONIRANJEM, ZA DRŠNA VRATA  
 (TR) SÜRGÜLÜ BAĞÇE KAPILARI VE KAPILAR İÇİN "O" PROFİL KIZAĞI, BETONLA SABITLENMİŞ  
 (AR) بسترة القواب والأواب المزقة "O" - دعامة ليلولة جانية  
 (CHN) 滑动门混凝土O型导轨  
 (MAL) PANDU PROFIL "O", KONKRIT, UNTUK PINTU PAGAR DAN PINTU GELONGSOR  
 (H) O-VEZETŐSÍN, BETONBA ÁGYAZOTT, TOLÓAJTÓKHOZ ÉS KAPUKHOZ  
 (IL) לשער הזזה לייקרה O מסילה  
 (BG) "O"-ОБРАЗЕН ПРОФИЛ, БЕТОНЕН, ЗА ПЛЪЗГАЩИ ПОРТИ И ВРАТИ  
 (KO) "O"자형 프로필 가이드, 콘크리트식, 슬라이딩 게이트 및 도어용  
 (SRB) VODICA „O“ PROFILA, UGRADNJA BETONIRANJEM, ZA KLIZNE KAPJE I VRATA

Art.	SURFACE FINISH	L/1pc	1pc		CODE	
			mm	kg	pcs	kg
VECTOR 6	GALVANIZED	6000	17,82	40	712,8	1720101
VECTOR 3	GALVANIZED	3000	8,91	40	356,4	1720102

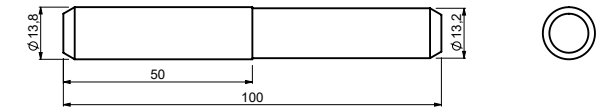

- (GB) FIXING PIN FOR PROFILE GUIDE  
 (D) FIXIERSTIFT FÜR PROFILFÜHRUNG  
 (F) GOUPILLE DE FIXATION POUR GUIDE DE PROFIL  
 (E) PERNO DE FIJACIÓN PARA GUÍA DE PERFIL  
 (P) PINO DE FIXAÇÃO PARA O GUIA DE PERFIL  
 (I) PERNO DI FISSAGGIO PER GUIDA PROFILATA  
 (DK) FASTGØRELSSESTIFT TIL PROFILVANGE  
 (NL) BEVESTIGINGSPLAAT VOOR PROFIELGELEIDER  
 (N) FESTE PINNE FOR PROFILSTYRING  
 (S) FIXERINGSSTIFT FÖR GEJDPROFIL  
 (FIN) KIINNITYSTAPPI PROFILIOHJAJMEEN  
 (PL) BOLEC USTALAJĄCY DO SZYNY  
 (SK) UPEVŇOVACÍ KOLÍK PRE VEDENIE PROFILU  
 (EE) FIKSEERIMISTIHV PROFILIJUHUKU JAOKS  
 (LT) PROFILIUOTO KREIPTUVO TVIRTINIMO KAIŠTIS  
 (LV) FIKSEJOŠĀ TAPA PROFILAM

Art.	GUIDE	1pc		CODE	
		kg	pcs	kg	
PIN VECTOR	VECTOR	0,11	10	1,1	1700348



- (CZ) FIXAČNÍ KOLÍK PRO PROFIL  
 (RO) PIVOT DE FIXARE PENTRU PROFILUL DE GHIDAJ  
 (HR) FIKSIRAJUĆI KLIN ZA PROFILNU VODILICU  
 (RUS) КРЕПЕЖНЫЙ ШТИФТ ДЛЯ НАПРАВЛЯЮЩЕГО РЕЛЬСА ПРОФИЛЯ  
 (SLO) PRITRDILNI ZATIČ ZA PROFILIRANO VODILO  
 (TR) PROFİL YATAĞI İÇİN SABITLEME PİMİ  
 (AR) مسمار التثبيت لوجه القطاع  
 (CHN) 型材导向装置固定销  
 (MAL) PIN IKATAN UNTUK PANDUAN PROFIL  
 (H) RÖGZÍTŐCSAP VEZETŐSÍNHEZ  
 (IL) פין קיבוע לפרויל מוביל  
 (BG) ФИКСИРАЩ БОЛТ ЗА РЕЛСА  
 (KO) 프로필 가이드용 고정 핀  
 (SRB) FIKSIRAJUĆI KLIN ZA PROFIL VODICE



S350 STRUCTURAL STEEL



 CUSTOMED SHAPE FOR OPTIMAL CONCRETE

 DEDICATED HOLE FOR CABLE TUBE

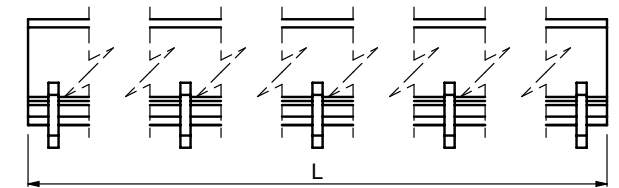
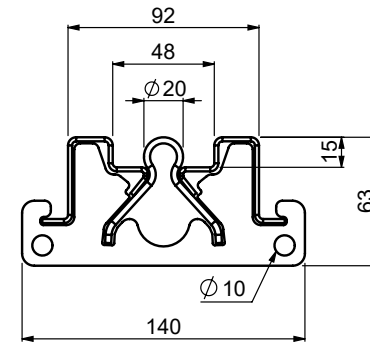
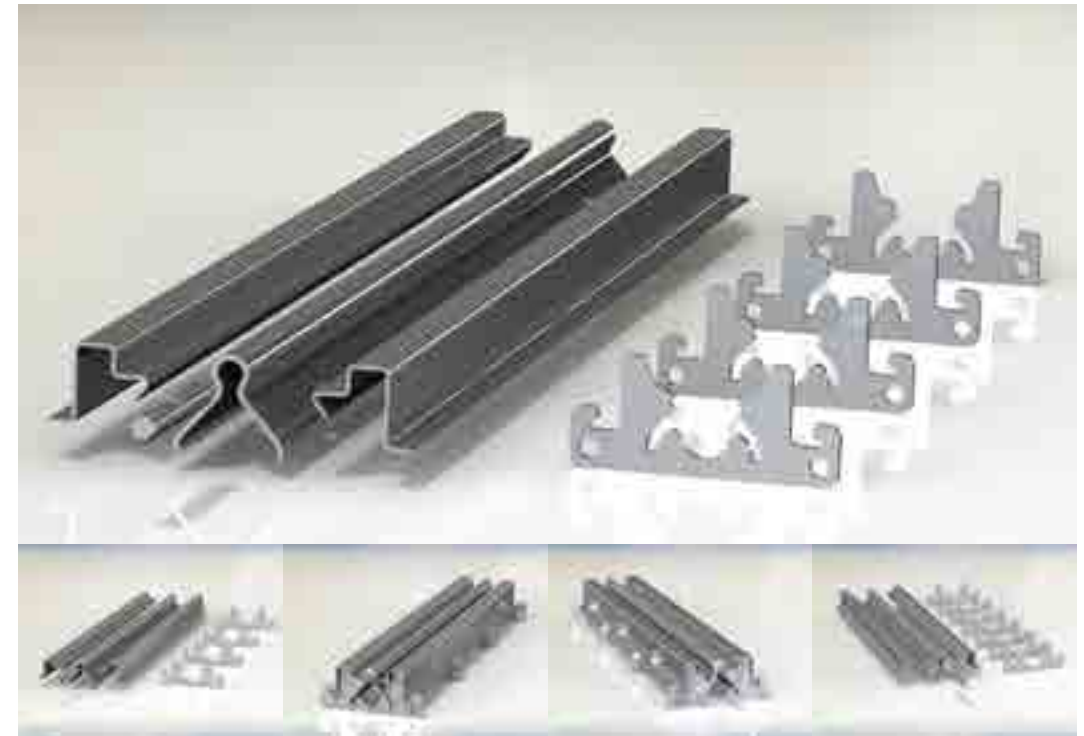

- (GB) „O“ PROFILE GUIDE, CONCRETED, WITH SIDE WALLS, FOR SLIDING GATES AND DOORS
- (D) „O“-PROFIL-FÜHRUNG, BETONIERT, MIT SEITENWÄNDEN, FÜR SCHIEBETORE UND -TÜREN
- (F) GUIDE PROFILÉ EN „O“, BÉTONNÉ, AVEC PAROIS LATÉRALES, POUR PORTAILS COULISSANTS ET PORTES
- (E) GUÍA DE PERFIL EN „O“, HORMIGONADA, CON PAREDES LATERALES, PARA PORTONES Y PUERTAS DESLIZANTES
- (P) GUÍA DE PERFIL „O“, CONCRETO, COM PAREDES LATERAIS, PARA PORTÕES E PORTAS DESLIZANTES
- (I) GUIDA CON PROFILO A „O“, CEMENTATA, CON PARETI LATERALI, PER PORTE E CANCELLI SCORREVOLI
- (DK) „O“ PROFILVANGE, BETONSTØBT, MED SIDEVÆGGE, TIL SKYDEPORTE OG DØRE
- (NL) „O“ PROFIELGELEIDER, GESTORT IN BETON, ZIJWANDEN, VOOR SCHUIFPOORTEN EN -DEUREN
- (N) „O“ PROFILSTYRING, INNSTØPT, MED SIDEVEGGER, FOR RULLEPORTER OG RULLEDØRER
- (S) „O“ GEJDPROFIL, BETONGAD MED SIDOVÄGGAR FÖR SKJUTGRINDAR OCH DÖRRAR
- (FIN) „O“-PROFILIOHJAIN, BETONIPÄÄLLYSTEELLÄ, SIVUSEINÄMILLÄ, LIUKUOPORTEIHIN JA -OVIIN
- (PL) SZYNA O PROFILU „O“, ZALEWANA W BETONIE, ZE ŚCIANKAMI BOCZNYMI, DO BRAM I DRZWI PRZESUWNYCH
- (SK) VODIACI PROFIL V TVARE „O“, BETÓNOVÝ, S BOČNÝMI STENAMI, PRE POSUVNÉ BRÁNY A DVERE
- (EE) „O“PROFILI JUHIK, BETONISEERITUD, KÜLGSEINTEGA, LIUGVÁRAVATE JA -USTE JAOKS
- (LT) „O“ FORMOS PROFILIUOTAS KREIPTUVAS, BETONUOTAS, SU ŠONINĖMIS SIENĖLĖMIS, SKIRTAS STUMDOMIESIEMS VARTAMS IR DURIMS
- (LV) „O“ VEIDA PROFILS, BETONĒTS, AR ŠĀNU SIENĀM, BĪDĀMAJĒM VĀRTIEM UN DURVĪM

- (CZ) ŠÍNA „O“ PROFIL S BOČNICEMI PRO POSUVNOU BRÁNU A VRATA K ZABETONOVÁNÍ
- (RO) PROFIL DE GHIDAJ „O“, BETONAT, CU PEREȚI LATERALI, PENTRU PORȚI ȘI UȘI CULISANTE
- (HR) „O“ PROFILNA VODILICA, BETONIRANA, S BOČNIM STUJENKAMA, ZA KLIZNA VRATA I VRATA
- (RUS) НАПРАВЛЯЮЩИЙ РЕЛЬС, ПРОФИЛЬ «О», БЕТНИРОВАННЫЙ, С БОКОВЫМИ СТЕНКАМИ, ДЛЯ РАЗДВИЖНЫХ ВОРОТ И ДВЕРЕЙ
- (SLO) „O“ VODILO, ZA PRITRDITEV Z BETONIRANJEM, S STRANSKIMI STENAMI, ZA DRSNNA VRATA
- (TR) SÜRGÜLÜ KAPILAR VE NORMAL KAPILAR İÇİN, BETONLANMIŞ, YAN ÇEPERLİ „O“ PROFİL YATAĞI
- (AR) موجه قطاع على شكل حرف "O" مغلف بالأسمنت، مع جدران جانبية، للوابواب المنزلقة
- (CHN) O型导向装置，混凝土，配有侧壁，适用于滑动门
- (MAL) PANDUAN PROFIL "O", BERKONKRIT, DENGAN DINDING TEPI, UNTUK GET GELONGSOR DAN PINTU
- (H) O-VEZETŐSÍN, BETONBA ÁGYAZOTT, OLDALFALAKKAL, TOLÓKAPUHOZ ÉS TOLÓAJTÓHOZ
- (IL) מנחה פתאע על שכל חרף "O" מכלפי באסמנטה, עם גדרן גבניתה, ללואבות האלוב المنزلقة
- (BG) „O“-ОБРАЗЕН ПРОФИЛ, ЗА БЕТONИРАНЕ, СЪС СТРАНИЧНИ СТЕНИ, ЗА ПЛЪЗГАЩИ ПОРТИ И ВРАТИ
- (KO) 슬라이딩 게이트 및 도어용 "O" 프로필 가이드, 콘크리트식, 측면 벽 포함
- (SRB) VODIČA „O“ PROFILA, UGRADNJA BETONIRANJEM, ZA KLIZNE KAPJE I VRATA



Art.	SURFACE FINISH	L/1pc	1pc			CODE
		mm	kg	pcs	kg	
VECTOR PACK 6	GALVANIZED	6000	40,81	20	816,2	1720107
VECTOR PACK 3	GALVANIZED	3000	20,46	20	409,2	1720108

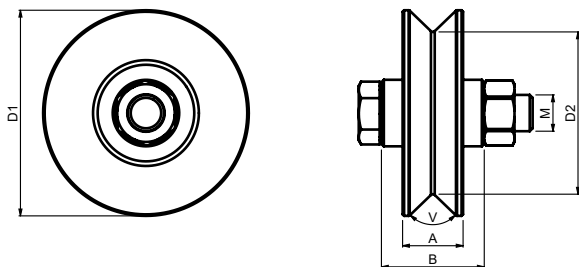



- (GB) „V” GROOVED WHEEL SINGLE BEARING
- (D) LAUFROLLE FÜR „V” PROFIL MIT LAGER
- (F) ROUE À GORGE EN « V » ET UN ROULEMENT
- (E) RODAMIENTO EXCLUSIVO CON RUEDA ROSCADA EN „V”
- (P) ROLAMENTO ÚNICO DE ROLDANA SULCADA EM „V”
- (I) RUOTA MONOCUSCINETTO CON SCANALATURA A „V”
- (DK) „V” HJUL MED RILLER ENKELT LEJE
- (NL) „V” WIEL ENKELE LAGER
- (N) „V”-RILLEDE HJUL MED ENKELTLAGER
- (S) ENKELLAGRAT SPÁRHJUL MED „V” SPÅR
- (FIN) „V”-URAINEN PYÖRÄ YKSITTÄISELLÄ LAAKERILLA
- (PL) ROLKA O PROFILU „V” Z POJEDYŃCZYM ŁOŻYSKIEM
- (SK) KLDKA SPODNÁ POJAZDOVÁ „V” PROFIL, JEDNOLOŽISKOVÁ
- (EE) „V” SOONILISE RATTA ÜKSIKLAAGER
- (LT) VIENGUBAS RATO GUOLIS SU „V” FORMOS GRIOVELIAIS
- (LV) „V” VEIDA PROFILA VELTŅA VIENRINDAS GULTNIS

- (CZ) KLDKA SPODNÍ POJEZDOVÁ „V” PROFIL, JEDNOLOŽISKOVÁ
- (RO) ROATĂ FORMĂ „V” CU UN SINGUR LĂGĂR
- (HR) KOTAČ S „V” UTOROM I JEDNIM LEŽAJEM
- (RUS) РОЛИК НИЖНИЙ, ПРОФИЛЬ «V», ОДНОПОДШИПНИКОВЫЙ
- (SLO) TEKALNO KOLO Z „V” UTOROM Z ENIM LEŽAJEM
- (TR) „V” ÖLÜKLU TEKERLEK, TEK RULMANLI
- (AR) محمل مزود بعملة مستعدة على شكل حرف „V”
- (CHN) „V”型槽轮单轴承
- (MAL) BEARING TUNGGAL RODA BERALUR „V”
- (H) V-HORNYS GÖRGŐ EGY CSAPÁGGYAL
- (IL) גלגל זוויתי בית סגור, מיסב בודד תמיכה חיצונית
- (BG) РОЛКА С ЕДИНИЧЕН ЛАГЕР ЗА „V”-ОБРАЗЕН ПРОФИЛ
- (KO) „V”자형 홈이 있는 휠 싱글 베어링
- (SRB) TOČKIĆ SA „V” ŽLEBOM I JEDNIM LEŽAJEM

Art.	D1	D2	A	B	M	V	BEARING	CAPACITY	1pc	Image		CODE
										kg	pcs	
	Ø		mm			v		kg	kg	pcs	kg	
WV 620	59	45	20	34	M12x50	92°	single	150	0,34	30	10,2	1700025
WV 820	78	64	20	34	M14x55	92°	single	150	0,65	20	13	1700026
WV 920	88	74	20	34	M14x55	92°	single	170	0,84	20	16,8	1700027
WV 1020	98	84	20	34	M14x55	92°	single	180	1,06	20	21,2	1700028

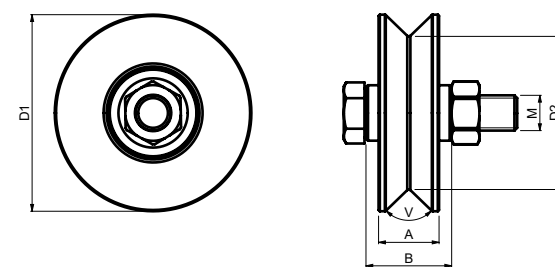

- (GB) „V” GROOVED WHEEL DOUBLE BEARING
- (D) „V”-NUT-RAD, DOPPELLAGER
- (F) ROUE RAINURÉE EN „V” DOUBLE ROULEMENT
- (E) RODAMIENTO DOBLE DE RUEDA RANURADA „V”
- (P) ROLAMENTO DUPLO DE RODA RANHURADA „V”
- (I) RUOTA A DOPPIO CUSCINETTO CON SCANALATURA A „V”
- (DK) DOBBELT LEJE MED „V”-RILLET HJUL
- (NL) „V” WIEL DUBBELE LAGER
- (N) „V”-SPOR HJUL DOBBELTLAGER
- (S) DUBBELLAGRAT SPÁRHJUL „V”
- (FIN) „V”-URAINEN PYÖRÄN KAKSOISLAAKERI
- (PL) ROLKA O PROFILU „V” Z PODWÓJNYM ŁOŻYSKIEM
- (SK) DVOJITÉ LOŽISKO S DRÁŽKAMI V TVARE „V”
- (EE) „V” SOONILISE RATTA TOPELTLAAGER
- (LT) DVIUGUBAS RATO GUOLIS SU „V” FORMOS GRIOVELIAIS
- (LV) „V” VEIDA PROFILA VELTŅA DIVRINDU GULTNIS

- (CZ) KLDKA SPODNÍ POJEZDOVÁ „V” PROFIL DVOULOŽISKOVÁ
- (RO) RULMENȚI DUBLI CU ROȚI DINȚATE ÎN FORMĂ DE „V”
- (HR) „V” ŽLJEVNI DVOSTRUKI LEŽAJ KOTAČA
- (RUS) РОЛИК НИЖНИЙ, ПРОФИЛЬ «V», ДВУХПОДШИПНИКОВЫЙ
- (SLO) DVOJNI LEŽAJ KOLESA Z „V” UTOROM
- (TR) „V” YIVLI TEKERLEKLI ÇİFT YATAK
- (AR) محمل مزدوج بعملة مستعدة على شكل حرف „V”
- (CHN) V槽轮双轴承
- (MAL) BEARING BERGANDA DENGAN RODA BERALUR „V”
- (H) V-HORNYS GÖRGŐ KÉT CSAPÁGGYAL
- (IL) גלגל זוויתי V מיסב כפול
- (BG) РОЛКА С ДВОЕН ЛАГЕР ЗА „V”-ОБРАЗЕН ПРОФИЛ
- (KO) „V”자형 홈이 있는 휠 더블 베어링
- (SRB) TOČKIĆ SA „V” ŽLEBOM I DVA LEŽAJA

Art.	D1	D2	A	B	M	V	BEARING	CAPACITY	1pc	Image		CODE
										kg	pcs	
	Ø		mm			v		kg	kg	pcs	kg	
WV 824 B2	78	61	24	34	M14x55	92°	double	260	0,78	10	7,8	1700257
WV 924 B2	88	71	24	34	M14x55	92°	double	280	1	10	10	1700258
WV 1024 B2	98	81	24	34	M14x55	92°	double	300	1,25	10	12,5	1700259
WV 1228 B2	118	98	28	44	M14x65	92°	double	460	2,09	6	12,54	1700260
WV 1430 B2	138	118	30	44	M14x65	92°	double	560	3,14	4	12,56	1700261
WV 1630 B2	158	138	30	44	M14x65	92°	double	580	4,18	2	8,36	1700262

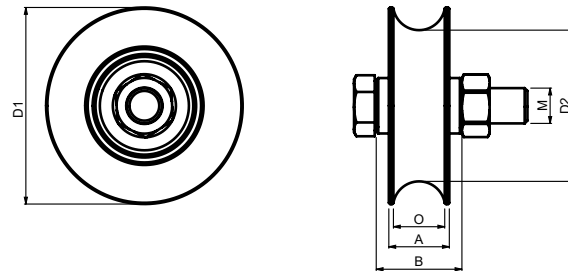

- (GB) „O“ GROOVED WHEEL SINGLE BEARING  
 (D) LAUFROLLE FÜR „O“ PROFIL MIT LAGER  
 (E) ROUE À GORGE EN «O» ET UN ROULEMENT  
 (E) RODAMIENTO EXCLUSIVO CON RUEDA ROSCADA EN “O”  
 (P) ROLAMENTO ÚNICO DE ROLDANA SULCADA EM “O”  
 (I) RUOTA MONOCUSCINETTO CON SCANALATURA A “O”  
 (DK) “O” HJUL MED RILLER ENKELT LEJE  
 (NL) “O” WIEL ENKELE LAGER  
 (N) “O”-RILLEDE HJUL MED ENKELTLAGER  
 (S) ENKELLAGRAT SPÅRHJUL MED “O” SPÅR  
 (FIN) “O”-URAINEN PYÖRÄ YKSITTÄISELLÄ LAAKERILLA  
 (PL) ROLKA O PROFILU „O” Z POJEDYNYM ŁOŻYSKIEM  
 (SK) KLDKA SPODNÁ POJAZDOVÁ „O” PROFIL, JEDNOLOŽISKOVÁ  
 (EE) “O” SOONILISE RATTÄ ÜKSIKLAAGER  
 (LT) VIENGUBAS RATO GUOLIS SU „O” FORMOS GRIOVELIAIS  
 (LV) “O” VEIDA PROFILA VELTŅA VIENRINDAS GULTNIS

- (CZ) KLDKA SPODNÍ POJEZDOVÁ „O” PROFIL, JEDNOLOŽISKOVÁ  
 (RO) ROATĂ FORMĂ „O” CU UN SINGUR LĂGĂR  
 (HR) KOTAČ S „O” UTOROM I JEDNIM LEŽAJEM  
 (RUS) РОЛИК НИЖНИЙ, ПРОФИЛЬ «О», ОДНОПОДШИПНИКОВЫЙ  
 (SLO) TEKALNO KOLO Z “O” UTOROM Z ENIM LEŽAJEM  
 (TR) “O” OLUKLU TEKERLEK, TEK RULMANLI  
 (AR) محمل مزوج بعجلة مخددة على شكل حرف “O”  
 (CHN) “O”型槽轮单轴承  
 (MAL) BEARING TUNGGAL RODA BERALUR “O”  
 (H) O-HORNYS GÖRGÖ EGY CSAPÁGGYAL  
 (IL) גלגל נורית O מיסב בודד O גלגל תמיכה חיצונית  
 (BG) РОЛКА С ЕДИНИЧЕН ЛАГЕР ЗА “O”-ОБРАЗЕН ПРОФИЛ  
 (KO) “O”자형 홈이 있는 휠 싱글 베어링  
 (SRB) TOČKIĆ SA „O” ŽLEBOM I JEDNIM LEŽAJEM

Art.	D1	D2	A	B	M	O	BEARING	CAPACITY	1pc	Image		CODE
										kg	kg	
	Ø		mm			Ø		kg	kg	pcs	kg	
WO 824	78	60	24	34	M14x55	21	single	150	0,62	20	12,4	1700029
WO 924	88	70	24	34	M14x55	21	single	170	0,83	20	16,6	1700221
WO 1024	98	80	24	34	M14x55	21	single	180	1,07	16	17,12	1700030

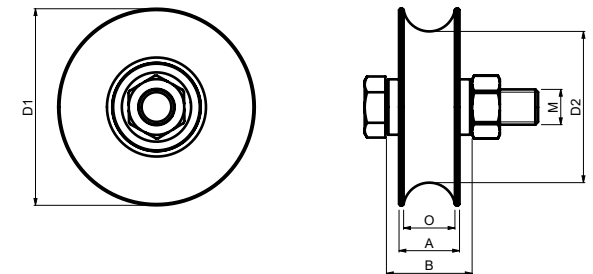

- (GB) „O” GROOVED WHEEL DOUBLE BEARING  
 (D) „O”-NUT-RAD, DOPPELLAGER  
 (F) ROUE RAINURÉE EN „O” DOUBLE ROULEMENT  
 (E) RODAMIENTO DOBLE DE RUEDA RANURADA “O”  
 (P) ROLAMENTO DUPLO DE RODA RANHURADA „O”  
 (I) RUOTA A DOPPIO CUSCINETTO CON SCANALATURA A „O”  
 (DK) DOBBELT LEJE MED “O”-RILLET HJUL  
 (NL) “O” WIEL DUBBELE LAGER  
 (N) „O”-SPOR HJUL DOBBELTLAGER  
 (S) DUBBELLAGRAT SPÅRHJUL „O”  
 (FIN) “O”-URAISEN PYÖRÄN KAKSOISLAAKERI  
 (PL) ROLKA O PROFILU „O” Z PODWÓJNYM ŁOŻYSKIEM  
 (SK) DVOJITÉ LOŽISKO S KOLESOM S DRÁŽKOU V TVARE „O”  
 (EE) “O” SOONILISE RATTÄ TOPELTLAAGER  
 (LT) DVIGUBAS RATO GUOLIS SU „O” FORMOS GRIOVELIAIS  
 (LV) “O” VEIDA PROFILA VELTŅA DIVRINDU GULTNIS

- (CZ) KLDKA SPODNÍ POJEZDOVÁ „O” PROFIL DVOULOŽISKOVÁ  
 (RO) RULMENȚI DUBLI CU ROTI DINȚATE ÎN FORMĂ DE „O”  
 (HR) “O” ŽLEBNI DVOSTRUKI LEŽAJ KOTAČA  
 (RUS) РОЛИК НИЖНИЙ, ПРОФИЛЬ «О», ДВУПОДШИПНИКОВЫЙ  
 (SLO) DVOJNI LEŽAJ KOLESA Z “O” UTOROM  
 (TR) “O” YIVLI TEKERLEKLI ÇİFT YATAK  
 (AR) محمل مزدوج بعجلة مخددة على شكل حرف “O”  
 (CHN) O槽轮双轴承  
 (MAL) BEARING BERGANDA DENGAN RODA BERALUR “O”  
 (H) O-HORNYS GÖRGÖ KÉT CSAPÁGGYAL  
 (IL) גלגל נורית O מיסב כפול  
 (BG) РОЛКА С ДВОЕН ЛАГЕР ЗА “O”-ОБРАЗЕН ПРОФИЛ  
 (KO) “O”자형 홈이 있는 휠 더블 베어링  
 (SRB) TOČKIĆ SA „O” ŽLEBOM I DVA LEŽAJA

Art.	D1	D2	A	B	M	O	BEARING	CAPACITY	1pc	Image		CODE
										kg	kg	
	Ø		mm			Ø		kg	kg	pcs	kg	
WO 824 B2	78	60	24	34	M14x55	21	double	260	0,68	10	6,8	1700263
WO 924 B2	88	70	24	34	M14x55	21	double	280	0,89	10	8,9	1700264
WO 1024 B2	98	80	24	34	M14x55	21	double	300	1,13	10	11,3	1700265
WO 1228 B2	118	100	28	44	M14x65	21	double	460	2,02	6	12,12	1700266
WO 1430 B2	138	120	30	44	M14x65	21	double	560	3,04	4	12,16	1700267
WO 1630 B2	158	140	30	44	M14x65	21	double	580	4,01	2	8,02	1700268

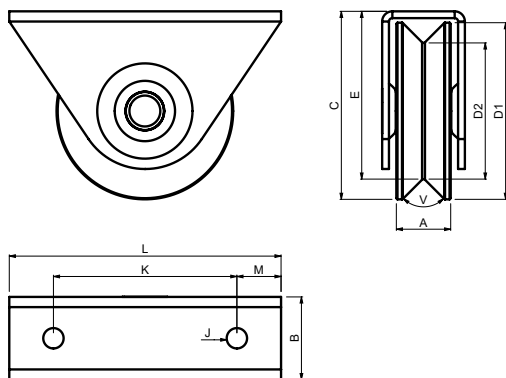
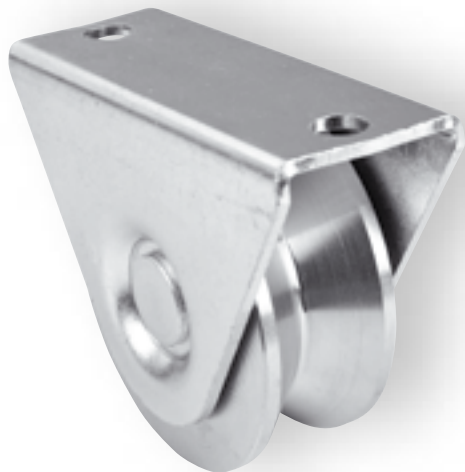

- (GB) „V“ GROOVED WHEEL SINGLE BEARING, EXTERNAL SUPPORT
- (D) LAUFROLLE FÜR „V“ PROFIL MIT STÜTZE UND LAGER
- (F) ROUE À GORGE EN « V » ET UN ROULEMENT, SUPPORT EXTERNE
- (E) RODAMIENTO EXCLUSIVO CON RUEDA ROSCADA EN „V“, SOPORTE EXTERNO
- (P) ROLAMENTO ÚNICO DE ROLDANA SULCADA EM „V“, SUPORTE EXTERNO
- (I) RUOTA MONOCUSCINETTO CON SCANALATURA A „V“, SOSTEGNO ESTERNO
- (DK) „V“ HJUL MED RILLER ENKELT LEJE, UDVENDIGT BESLAG
- (NL) „V“ WIEL ENKELE LAGER, EXTERNE STEUN
- (N) „V“-RILLEDE HJUL MED ENKELTLAGER, UTVENDIG STØTTE
- (S) ENKELLAGRAT SPÅRHJUL MED „V“ SPÅR , EXTERN STÖD
- (FIN) „V“-URAINEN PYÖRÄ YKSITTÄISELLÄ LAAKERILLA, ULKOINEN TUKI
- (PL) ROLKA O PROFILU „V“ Z POJĘDNYCZYM ŁOŻYSKIEM, PODPARCIE ZEWNĘTRZNE
- (SK) KLADKA SPODNÁ POJEZDOVÁ „V“ PROFIL S VONKAJŠOU PODPEROU, JEDNOLOŽISKOVÁ
- (EE) „V“ SOONILISE RATTÄ ÜKSIKLAAGER, VÄLISTUGI
- (LT) VIENGBAS RATO GUOLIS SU „V“ FORMOS GRIOVELIAIS, IŠORINĖ ATRAMA
- (LV) „V“ VEIDA PROFILA VĒLTŅĀ VIENRINDAS GULTNIS, ĀRĒJAIS BALSTS

- (CZ) KLADKA SPODNÍ POJEZDOVÁ „V“ PROFIL S VNĚJŠÍ PODPĚROU, JEDNOLOŽISKOVÁ
- (RO) ROATĂ FORMĂ „V“ CU UN SINGUR LĂGĂR, SUPORT EXTERN
- (HR) KOTAČ S „V“ UTOROM I JEDNIM LEŽAJEM, VANJSKI DRŽAČ
- (RUS) РОЛИК НИЖНИЙ, ПРОФИЛЬ «V», С ВНЕШНИМ КРОНШТЕЙНОМ, ОДНОПОДШИПНИКОВЫЙ
- (SLO) TEKALNO KOLO Z „V“ UTOROM Z ENIM LEŽAJEM, ZUNANJI PODPORNIK
- (TR) „V“ OLUKLU TEKERLEK, TEK RULMANLI, HARİCİ DESTEK
- (AR) حامل قروي للعملة المخدنة „V“، دعامة خارجية
- (CHN) „V“ 型槽轮单轴承，外支架
- (MAL) BEARING TUNGGAL RODA BERALUR „V“, SOKONGAN LUARAN
- (H) V-HORNÝOS GÖRGŐ KÉT CSAPÁGGYAL, KÜLSŐ MEGTÁMASZÁSSAL
- (IL) גלגל זרוף V מוסב כפול, תמיכה חיצונית
- (BG) РОЛКА С ЕДИНИЧЕН ЛАГЕР ЗА „V“-ОБРАЗЕН ПРОФИЛ, ВЪНШНА ПОДДЪРЪЖКА
- (KO) „V“자형 홈이 있는 휠 상글 베어링, 외부 지지대
- (SRB) TOČKIĆ SA „V“ ŽLEBOM I JEDNIM LEŽAJEM, SPOLJAŠNJI DRŽAČ

Art.	D1	D2	A	B	C	E	J	K	L	M	V	BEARING	CAPACITY	1pc		CODE	
	Ø						Ø	mm			v		kg	kg	pcs	kg	
WTV 624	58	42	24	36	65	57	8	65	80	8	92°	single	100	0,54	12	6,48	1700031
WTV 824	78	61	24	36	83	74	9	90	120	15	92°	single	150	0,96	10	9,6	1700032

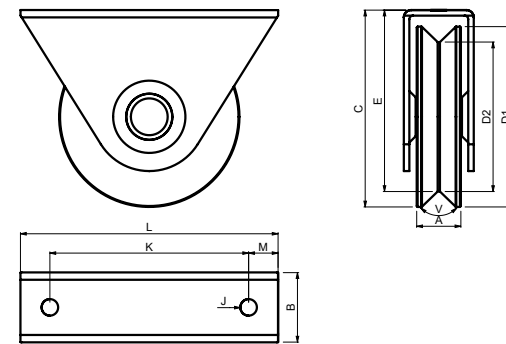

- (GB) „V“ GROOVED WHEEL DOUBLE BEARING, EXTERNAL SUPPORT
- (D) „V“-NUT-RAD, DOPPELLAGER, EXTERNE STÜTZE
- (F) ROUE RAINURÉE EN „V“ DOUBLE ROULEMENT, SUPPORT EXTERNE
- (E) RODAMIENTO DOBLE DE RUEDA RANURADA „V“, SOPORTE EXTERNO
- (P) ROLAMENTO DUPLO DE RODA RANHURADA „V“, SUPORTE EXTERNO
- (I) RUOTA A DOPPIO CUSCINETTO CON SCANALATURA A „V“, SOSTEGNO ESTERNO
- (DK) DOBBELT LEJE MED „V“-RILLET HJUL, EKSTERN STØTTE
- (NL) „V“ WIEL DUBBELE LAGER, EXTERNE STEUN
- (N) „V“-SPOR HJUL DOBBELTLAGER, EKSTERN STØTTE
- (S) DUBBELLAGRAT SPÅRHJUL „V“, EXTERN STÖD
- (FIN) „V“-URAISEN PYÖRÄN KAKSOISLAAKERI, ULKOINEN TUKI
- (PL) ROLKA O PROFILU „V“ Z PODWÓJNYM ŁOŻYSKIEM, PODPARCIE ZEWNĘTRZNE
- (SK) DVOJITÉ LOŽISKO S KOLESOM S DRÁŽKOU V TVARE „V“, VONKAJŠIA PODPORA
- (EE) „V“ SOONILISE RATTÄ TOPELTLAAGER, VÄLISTUGI
- (LT) DVIGUBAS RATO GUOLIS SU „V“ FORMOS GRIOVELIAIS, IŠORINĖ ATRAMA
- (LV) „V“ VEIDA PROFILA VĒLTŅĀ DIVRINDU GULTNIS, ĀRĒJAIS BALSTS

- (CZ) KLADKA SPODNÍ POJEZDOVÁ „V“ PROFIL S VNĚJŠÍ PODPĚROU DVOULOŽISKOVÁ
- (RO) RULMENȚI DUBLI CU ROȚI DINȚATE ÎN FORMĂ DE „V“, SUPORT EXTERN
- (HR) „V“ ŽLJEBNI DVOSTRUKI LEŽAJ KOTAČA, VANJSKI POTPORANJ
- (RUS) РОЛИК НИЖНИЙ, ПРОФИЛЬ «V», ДВУХПОДШИПНИКОВЫЙ, ВНЕШНЯЯ ОПОРА
- (SLO) TEKALNO KOLO Z „V“ UTOROM Z DVEMA LEŽAJEMA, ZUNANJI PODPORNIK
- (TR) „V“ YIVLI TEKERLEKLI ÇİFT YATAK, DIŞ DESTEK
- (AR) حامل مزدوج بعجلة مخدنة على شكل حرف «V»، دعامة خارجية
- (CHN) V槽轮双轴承，外部支架
- (MAL) BEARING BERGANDA DENGAN RODA BERALUR „V“, BANTUAN LUARAN
- (H) V-HORNÝOS GÖRGŐ KÉT CSAPÁGGYAL, KÜLSŐ MEGTÁMASZÁSSAL
- (IL) גלגל זרוף V מוסב כפול, תמיכה חיצונית
- (BG) РОЛКА С ДВОЕН ЛАГЕР ЗА „V“-ОБРАЗЕН ПРОФИЛ, ВЪНШНА ПОДДЪРЪЖКА
- (KO) „V“자형 홈이 있는 휠 더블 베어링, 외부 지지대
- (SRB) TOČKIĆ SA „V“ ŽLEBOM I DVA LEŽAJA, SPOLJAŠNJI DRŽAČ

Art.	D1	D2	A	B	C	E	J	K	L	M	V	BEARING	CAPACITY	1pc		CODE	
	Ø						Ø	mm			v		kg	kg	pcs	kg	
WTV 1024 B2	98	81	24	38	107	98	9	108	140	16	92°	double	300	1,63	10	16,3	1700269

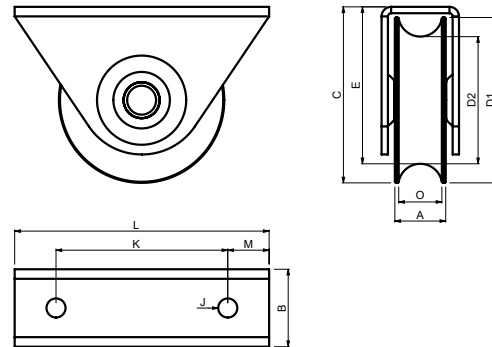

- (GB) „O” GROOVED WHEEL SINGLE BEARING, EXTERNAL SUPPORT
- (D) LAUFROLLE FÜR „O” PROFIL MIT STÜTZE UND LAGER
- (F) ROUE À GORGE EN «O» ET UN ROULEMENT, SUPPORT EXTERNE
- (E) RODAMIENTO EXCLUSIVO CON RUEDA ROSCADENA EN “O”, SOPORTE EXTERNO
- (P) ROLAMENTO ÚNICO DE ROLDANA SULCADA EM “O”, SUPORTE EXTERNO
- (I) RUOTA MONOCUSCINETTO CON SCANALATURA A “O”, SOSTEGNO ESTERNO
- (DK) “O” HJUL MED RILLER ENKELT LEJE, UDVENDIGT BESLAG
- (NL) “O” WIEL ENKELE LAGER, EXTERNE STUUN
- (N) “O”-RILLEDE HJUL MED ENKELTLAGER, UTVENDIG STØTTE
- (S) ENKELLAGRAT SPÅRHJUL MED “O” SPÅR, EXTERN STÖD
- (FIN) “O”-URAINEN PYÖRÄ YKSITTÄISELLÄ LAAKERILLA, ULKOINEN TUKI
- (PL) ROLKA O PROFILU „O” Z POJĘDNYCZYM ŁOŻYSKIEM, PODPARCIE ZEWNĘTRZNE
- (SK) KLDKA SPODNÁ POJAZDOVÁ „O” PROFIL S VONKAJŠOU PODPEROU, JEDNOLOŽISKOVÁ
- (EE) “O” SOONILISE RATTA ÜKSIKLAAGER, VÄLISTUGI
- (LT) VIENGUBAS RATO GUOLIS SU „O” FORMOS GROIVELIAIS, IŠORINĖ ATRAMA
- (LV) “O” VEIDA PROFILA VELTNĀ VIENRINDAS GULTNIS, ĀRĒJAIS BALSTS

- (CZ) KLDKA SPODNÍ POJEZDOVÁ „O” PROFIL S VNĚJŠÍ PODPĚROU, JEDNOLOŽISKOVÁ
- (RO) ROATĂ FORMĂ „O” CU UN SINGUR LAGĂR, SUPORT EXTERN
- (HR) KOTAČ S „O” UTOROM I JEDNIM LEŽAJEM, VANJSKI DRŽAČ
- (RUS) РОЛИК НИЖНИЙ, ПРОФИЛЬ «О», С ВНЕШНИМ КРОНШТЕЙНОМ, ОДНОПОДШИПНИКОВЫЙ
- (SLO) TEKALNO KOLO Z “O” UTOROM Z ENIM LEŽAJEM, ZUNANJI PODPORNİK
- (TR) “O” OLUKLU TEKERLEK, TEK RULMANLI, HARİCİ DESTEK
- (AR) معمل مزودج بعجلة مكددة على شكل حرف “O” ددعة خارجية
- (CHN) “O”型槽轮单轴承, 外支架
- (MAL) BEARING TUNGGAL RODA BERALUR “O”, SOKONGAN LUARAN
- (H) O-HORNYS GÖRGÖ EGY CSAPÁGGYAL, KÜLSŐ MEGTÁMASZTÁSSAL
- (IL) בית סגור, מונח בודד U מוגל
- (BG) РОЛКА С ЕДИНИЧЕН ЛАГЕР ЗА “O”-ОБРАЗЕН ПРОФИЛ, ВЪНШНА ПОДПОРКА
- (KO) “O”자형 홈이 있는 휠 싱글 베어링, 외부 지지대
- (SRB) TOČKIC SA „O” ŽLEBOM I JEDNIM LEŽAJEM, SPOLJAŠNJI DRŽAČ

Art.	D1	D2	A	B	C	E	J	K	L	M	O	BEARING	CAPACITY	1pc		CODE	
														kg	pcs		kg
WTO 625	58	40	24	36	65	55	8	65	80	8	21	single	100	0,47	12	5,64	1700033
WTO 825	78	60	24	36	83	73	9	90	120	15	21	single	150	0,86	10	8,6	1700034

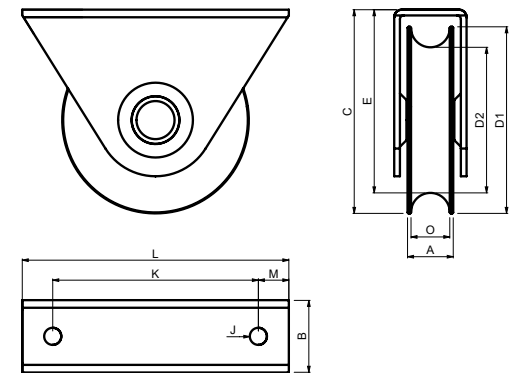

- (GB) „O” GROOVED WHEEL DOUBLE BEARING, EXTERNAL SUPPORT
- (D) „O”-NUT-RAD, DOPPELLAGER, EXTERNE STÜTZE
- (F) ROUE RAINURÉE EN „O” DOUBLE ROULEMENT, SUPPORT EXTERNE
- (E) RODAMIENTO DOBLE DE RUEDA RANURADA “O”, SOPORTE EXTERNO
- (P) ROLAMENTO DUPLO DE RODA RANHURADA „O”, SUPORTE EXTERNO
- (I) RUOTA A DOPPIO CUSCINETTO CON SCANALATURA A „O”, SOSTEGNO ESTERNO
- (DK) DOBBELT LEJE MED “O”-RILLET HJUL, EKSTERN STØTTE
- (NL) “O” WIEL DUBBELE LAGER, EXTERNE STEUN
- (N) “O” -SPOR HJUL DOBBELTLAGER, EKSTERN STØTTE
- (S) DUBBELLAGRAT SPÅRHJUL „O”, EXTERN STÖD
- (FIN) “O”-URAISEN PYÖRÄN KAKSOISLAAKERI, ULKOINEN TUKI
- (PL) ROLKA O PROFILU „O” Z PODWÓJNYM ŁOŻYSKIEM, PODPARCIE ZEWNĘTRZNE
- (SK) „DVOJITÉ LOŽISKO S KOLESOM S DRÁŽKOU V TVARE „O”, VONKAJŠIA PODPORA
- (EE) “O” SOONILISE RATTA TOPELTLAAGER, VÄLISTUGI
- (LT) DVIGUBAS RATO GUOLIS SU „O” FORMOS GROIVELIAIS, IŠORINĖ ATRAMA
- (LV) “O” VEIDA PROFILA VELTNĀ DIVRINDU GULTNIS, ĀRĒJAIS BALSTS

- (CZ) KLDKA SPODNÍ POJEZDOVÁ „O” PROFIL S VNĚJŠÍ PODPĚROU, DVOULOŽISKOVÁ
- (RO) RULMENȚI DUBLI CU ROTI DINȚATE ÎN FORMĂ DE „O”, SUPORT EXTERN
- (HR) “O” ŽLJEBNI DVOSTRUKI LEŽAJ KOTAČA, VANJSKI POTPORANJ
- (RUS) РОЛИК НИЖНИЙ, ПРОФИЛЬ «О», ДВУХПОДШИПНИКОВЫЙ, ВНЕШНЯЯ ОПОРА
- (SLO) TEKALNO KOLO Z “O” UTOROM Z DVEMA LEŽAJEMA, ZUNANJI PODPORNİK
- (TR) “O” YIVLİ TEKERLEKLİ ÇİFT YATAK, DIŞ DESTEK
- (AR) معمل مزودج بعجلة مكددة على شكل حرف “O” ددعة خارجية
- (CHN) O槽轮双轴承槽轮双轴承, 外部支架
- (MAL) BEARING BERGANDA DENGAN RODA BERALUR “O”, BANTUAN LUARAN
- (H) O-HORNYS GÖRGÖ KÉT CSAPÁGGYAL, KÜLSŐ MEGTÁMASZTÁSSAL
- (IL) גלגל מזודג בעגלה מكددة על شكل حرف "O" דדעה חיצונית
- (BG) РОЛКА С ДВОЕН ЛАГЕР ЗА “O”-ОБРАЗЕН ПРОФИЛ, ВЪНШНА ПОДПОРКА
- (KO) “O”자형 홈이 있는 휠 더블 베어링, 외부 지지대
- (SRB) TOČKIC SA „O” ŽLEBOM I DVA LEŽAJA, SPOLJAŠNJI DRŽAČ

Art.	D1	D2	A	B	C	E	J	K	L	M	O	BEARING	CAPACITY	1pc		CODE	
														kg	pcs		kg
WTO 1024 B2	98	80	24	38	107	97	9	108	140	16	21	double	300	1,5	10	15	1700270

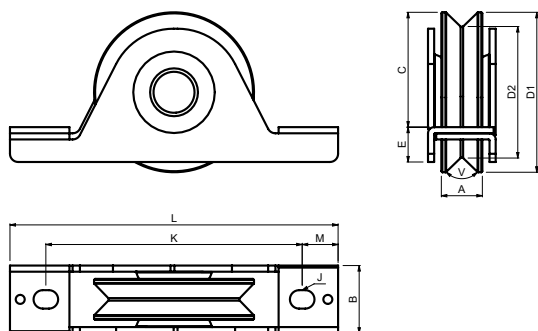

- (GB) „V“ GROOVED WHEEL SINGLE BEARING, INTERNAL SUPPORT
- (D) LAUFROLLE MIT „V“ PROFIL MIT STÜTZE UND LAGER
- (F) ROUE À GORGE EN «V» ET UN ROULEMENT SUPPORT INTERNE
- (E) RODAMIENTO EXCLUSIVO CON RUEDA ROSCADA EN „V“, SOPORTE INTERNO
- (P) ROLAMENTO ÚNICO DE ROLDANA SULCADA EM „V“, SUPORTE INTERNO
- (I) RUOTA MONOCUSCINETTO CON SCANALATURA A „V“, SOSTEGNO INTERNO
- (DK) „V“ HJUL MED RILLER ENKELT LEJE, INDVENDIGT BESLAG
- (NL) „V“ WIEL ENKELE LAGER, INTERNE STEUN
- (N) „V“-RILLEDE HJUL MED ENKELTLAGER, INNVENDIG STØTTE
- (S) ENKELLAGRAT SPÅRHJUL MED „V“ SPÅR, INTERN STÖD
- (FIN) „V“-URAINEN PYÖRÄ YKSITTÄISELLÄ LAAKERILLA, SISÄINEN TUKI
- (PL) ROLKA O PROFILU „V“ Z POJEDYNCZYM ŁOŻYSKIEM, PODPARCIE WEWNĘTRZNE
- (SK) KLADKA SPODNÁ POJEZDOVÁ „V“ PROFIL S VNÚTORNOU PODPEROU, JEDNOLOŽISKOVÁ
- (EE) „V“ SOONILISE RATTA ÜKSIKLAAGER, SISETUGI
- (LT) VIENGUBAS RATO GUOLIS SU „V“ FORMOS GROIVELIAIS, VIDINĖ ATRAMA
- (LV) „V“ VEIDA PROFILA VELTNĀ VIENRINDAS GULTNIS, IEKŠĒJAIS BALSTS

- (CZ) KLADKA SPODNÍ POJEZDOVÁ „V“ PROFIL S VNITŘNÍ PODPĚROU, JEDNOLOŽISKOVÁ
- (RO) ROATĂ FORMĂ „V“ CU UN SINGUR LĂGĂR, SUPORT INTERN
- (HR) KOTAČ S „V“ UTOROM I JEDNIM LEŽAJEM, UNUTARNJI DRŽAČ
- (RUS) РОЛИК НИЖНИЙ, ПРОФИЛЬ «V», С ВНУТРЕННИМ КРОНШТЕЙНОМ, ОДНОПОДШИПНИКОВЫЙ
- (SLO) TEKALNO KOLO Z „V“ UTOROM Z ENIM LEŽAJEM, NOTRANJI PODPORNIK
- (TR) „V“ ÖLÜKLU TEKERLEK, TEK RULMANLI, DAHİLİ DESTEK
- (AR) دعمه الداخلي «V» محمل فودي للمجلة المنخفضة
- (CHN) „V“ 型槽轮单轴承, 内支架
- (MAL) BEARING TUNGGAL RODA BERALUR „V“, SOKONGAN DALAMAN
- (H) V-HORNYS GÖRGŐ EGY CSAPÁGGYAL, A GÖRGŐ A MEGTÁMASZTÁSBA SÜLLYED
- (IL) גלגל זווית V בתחתית, מיסב בודד המיכה פנימית
- (BG) РОЛКА С ЕДИНИЧЕН ЛАГЕР ЗА „V“-ОБРАЗЕН ПРОФИЛ, ВЪТРЕШНА ПОДДПОРА
- (KO) „V“자형 홈이 있는 휠 상글 베어링, 내부 지지대
- (SRB) TOČKIC SA „V“ ŽLEBOM I JEDNIM LEŽAJEM, UNUTRAŠNJI DRŽAČ

Art.	D1	D2	A	B	C	E	J	K	L	M	V	BEARING	CAPACITY	1pc	📦		CODE
	mm														kg	kg	
WSV 820	78	64	20	33	56	17	9x12	124	160	18	92°	single	150	0,86	12	10,32	1700035
WSV 920	88	74	20	33	61	17	9x12	124	160	18	92°	single	170	1,05	12	12,6	1700036
WSV 1020	98	84	20	33	66	17	9x12	124	16	18	92°	single	180	1,26	10	12,6	1700037

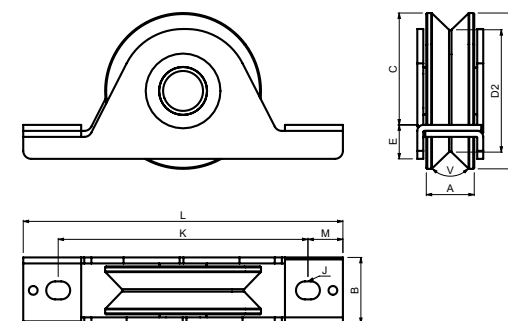

- (GB) „V“ GROOVED WHEEL DOUBLE BEARING, INTERNAL SUPPORT
- (D) „V“-NUT-RAD, DOPPELLAGER, INTERNE STÜTZE
- (F) ROUE RAINURÉE EN „V“ DOUBLE ROULEMENT, SUPPORT INTERNE
- (E) RODAMIENTO DOBLE DE RUEDA RANURADA „V“, SOPORTE INTERNO
- (P) ROLAMENTO DUPLO DE RODA RANHURADA „V“, SUPORTE INTERNO
- (I) RUOTA A DOPPIO CUSCINETTO CON SCANALATURA A „V“, SOSTEGNO INTERNO
- (DK) DOBBELT LEJE MED „V“-RILLET HJUL, INTERN STØTTE
- (NL) „V“ WIEL DUBBELE LAGER, INTERNE STEUN
- (N) „V“-SPOR HJUL DOBBELTLAGER, INTERN STØTTE
- (S) DUBBELLAGRAT SPÅRHJUL „V“, INTERN STÖD
- (FIN) „V“-URAINEN PYÖRÄN KAKSOISLAAKERI, SISÄINEN TUKI
- (PL) ROLKA O PROFILU „V“ Z PODWÓJNYM ŁOŻYSKIEM, PODPARCIE WEWNĘTRZNE
- (SK) DVOJITÉ LOŽISKO S KOLESOM S DRÁŽKOU V TVARE „V“, VNÚTORNÁ PODPORA
- (EE) „V“ SOONILISE RATTA TOPELTLAAGER, SISETUGI
- (LT) DVIUGUBAS RATO GUOLIS SU „V“ FORMOS GROIVELIAIS, VIDINĖ ATRAMA
- (LV) „V“ VEIDA PROFILA VELTNĀ DIVRINDU GULTNIS, IEKŠĒJAIS BALSTS

- (CZ) KLADKA SPODNÍ POJEZDOVÁ „V“ PROFIL S VNITŘNÍ PODPĚROU DVOULOŽISKOVÁ
- (RO) RULMENȚI DUBLI CU ROȚI DINȚATE ÎN FORMĂ DE „V“, SUPORT INTERN
- (HR) „V“ ŽLJEJNI DVOSTRUKI LEŽAJ KOTAČA, UNUTRAŠNJI POTPORANJ
- (RUS) РОЛИК НИЖНИЙ, ПРОФИЛЬ «V», ДВУПОДШИПНИКОВЫЙ, ВНУТРЕННЯЯ ОПОРА
- (SLO) TEKALNO KOLO Z „V“ UTOROM Z DVEMA LEŽAJEMA, NOTRANJI PODPORNIK
- (TR) „V“ YIVLİ TEKERLEKLI ÇİFT YATAK, İÇ DESTEK
- (AR) محمل مزدوج لمجلة منخفضة على شكل حرف «V» دعمه الداخلي
- (CHN) V槽轮双轴承, 内部支架
- (MAL) BEARING BERGANDA DENGAN RODA BERALUR „V“, BANTUAN DALAMAN
- (H) V-HORNYS GÖRGŐ KÉT CSAPÁGGYAL, A GÖRGŐ A MEGTÁMASZTÁSBA SÜLLYED
- (IL) גלגל זווית V מיסב כפול, המיכה פנימית
- (BG) РОЛКА С ДВОЕН ЛАГЕР ЗА „V“-ОБРАЗЕН ПРОФИЛ, ВЪТРЕШНА ПОДДРЪЖКА
- (KO) „V“자형 홈이 있는 휠 더블 베어링, 내부 지지대
- (SRB) TOČKIC SA „V“ ŽLEBOM I DVA LEŽAJA, UNUTRAŠNJI DRŽAČ

Art.	D1	D2	A	B	C	E	J	K	L	M	V	BEARING	CAPACITY	1pc	📦		CODE
	mm														kg	kg	
WSV 824 B2	78	61	24	33	56	17	9x12	124	160	18	92°	double	260	1,01	12	12,12	1700271
WSV 924 B2	88	71	24	33	61	17	9x12	124	160	18	92°	double	280	1,24	12	14,88	1700272
WSV 1024 B2	98	81	24	33	66	17	9x12	124	160	18	92°	double	300	1,49	10	14,9	1700273
WSV 1228 B2	118	98	28	39	83	18	9x12	150	190	20	92°	double	360	2,44	6	14,64	1700274
WSV 1630 B2	158	138	30	44	116	20	11x16	210	250	20	92°	double	480	5,11	2	10,22	1700275

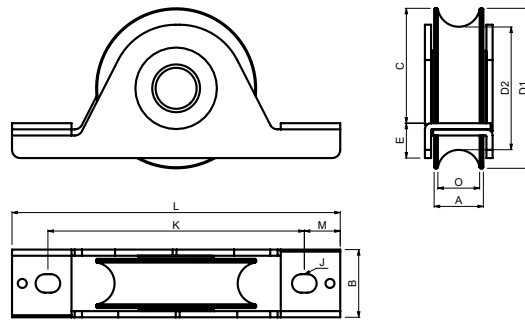

- (GB) „O“ GROOVED WHEEL SINGLE BEARING, INTERNAL SUPPORT
- (D) LAUFROLLE MIT „O“ PROFIL MIT STÜTZE UND LAGER
- (F) ROUE À GORGE EN « O » ET UN ROULEMENT, SUPPORT INTERNE
- (E) RODAMIENTO EXCLUSIVO CON RUEDA ROSCADA EN "O", SOPORTE INTERNO
- (P) ROLAMENTO ÚNICO DE ROLDANA SULCADA EM "O", SUPORTE INTERNO
- (I) RUOTA MONOCUSCINETTO CON SCANALATURA A "O", SOSTEGNO INTERNO
- (DK) "O" HJUL MED RILLER ENKELT LEJJE, INDVENDIGT BESLAG
- (NL) "O" WIEL ENKELE LAGER, INTERNE STEUN
- (N) "O"-RILLEDE HJUL MED ENKELTLAGER, INNVENDIG STØTTE
- (S) ENKELLAGRAT SPÅRHJUL MED "O" SPÅR, INTERN STÖD
- (FIN) "O"-URAINEN PYÖRÄ YKSITTÄISELLÄ LAAKERILLA, SISÄINEN TUKI
- (PL) ROLKA O PROFILU „O“ Z PODJÓJNYM ŁOŻYSKIEM, PODPARCIE WEWNĘTRZNE
- (SK) KLADKA SPODNÁ POJAZDOVÁ „O“ PROFIL S VNÚTORNOU PODPEROU, JEDNOLOŽISKOVÁ
- (EE) "O" SOONILISE RATTA ÜKSIKLAAGER, SISETUGI
- (LT) VIENGUBAS RATO GUOLIS SU „O“ FORMOS GRIOVELIAIS, VIDINĖ ATRAMA
- (LV) "O" VEIDA PROFILA VĒLTŅA VIENRINDAS GULTNIS, IEKŠĒJAIS BALSTS

- (CZ) KLADKA SPODNÍ POJEZDOVÁ „O“ PROFIL S VNITŘNÍ PODPĚROU, JEDNOLOŽISKOVÁ
- (RO) ROATĂ FORMĂ „O“ CU UN SINGUR LAGĂR, SUPORT INTERN
- (HR) KOTAČ S „O“ UTOROM I JEDNIM LEŽAJEM, UNUTARNJI DRŽAČ
- (RUS) РОЛИК НИЖНИЙ, ПРОФИЛЬ «O», С ВНУТРЕННИМ КРОШТЕЙНОМ, ОДНОПОДШИПНИКОВЫЙ
- (SLO) TEKALNO KOLO Z "O" UTOROM Z ENIM LEŽAJEM, NOTRANJI PODPORNİK
- (TR) "O" ÖLÜKLU TEKERLEK, TEK RULMANLI, DAHİLİ DESTEK
- (AR) محمل مزوج للعجلة مخددة على شكل حرف "O" دعامة داخلية
- (CHN) "O"型槽轮单轴承, 内支架
- (MAL) BEARING TUNGGAL RODA BERALUR "O", SOKONGAN DALAMAN
- (H) O-HORNÝOS GÖRGŐ KÉT CSAPÁGGYAL, A GÖRGŐ A MEGTÁMASZTÁSBA SÜLLYED
- (IL) בית פתוח, מסב בודד U גלגל O
- (BG) РОЛКА С ЕДИНИЧЕН ЛАГЕР ЗА "O"-ОБРАЗЕН ПРОФИЛ, ВЪТРЕШНА ПОДПОРА
- (KO) "O"자형 홈이 있는 휠 단일 베어링, 내부 지지대
- (SRB) TOČKIĆ SA „O“ ŽLEBOM I JEDNIM LEŽAJEM, UNUTRAŠNJI DRŽAČ

Art.	D1	D2	A	B	C	E	J	K	L	M	O	BEARING	CAPACITY	1pc		CODE	
														kg	pcs		kg
												mm					
WSO 824	78	60	24	33	56	17	9x12	124	160	18	21	single	150	0,83	12	9,96	1700039
WSO 924	88	70	24	33	61	17	9x12	124	160	18	21	single	170	1,04	12	12,48	1700040
WSO 1024	98	80	24	33	66	17	9x12	124	160	18	21	single	180	1,28	10	12,8	1700041

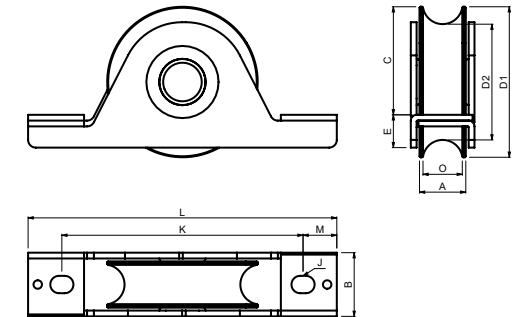

- (GB) „O“ GROOVED WHEEL DOUBLE BEARING, INTERNAL SUPPORT
- (D) „O“-NUT-RAD, DOPPELLAGER, INTERNE STÜTZE
- (F) ROUE RAINURÉE EN „O“ DOUBLE ROULEMENT, SUPPORT INTERNE
- (E) RODAMIENTO DOBLE DE RUEDA RANURADA "O", SOPORTE INTERNO
- (P) ROLAMENTO DUPLO DE RODA RANHURADA „O“, SUPORTE INTERNO
- (I) RUOTA A DOPPIO CUSCINETTO CON SCANALATURA A „O“, SOSTEGNO INTERNO
- (DK) DOBBELT LEJJE MED "O"-RILLET HJUL, INTERN STØTTE
- (NL) "O" WIEL DUBBELE LAGER, INTERNE STEUN
- (N) "O"-SPOR HJUL DOBBELTLAGER, INTERN STØTTE
- (S) DUBBELLAGRAT SPÅRHJUL „O“, INTERN STÖD
- (FIN) "O"-URAINEN PYÖRÄN KAKSOISLAAKERI, SISÄINEN TUKI
- (PL) ROLKA O PROFILU „O“ Z PODJÓJNYM ŁOŻYSKIEM, PODPARCIE WEWNĘTRZNE
- (SK) DVOJITÉ LOŽISKO S KOLESOM S DRÁŽKOU V TVARE „O“, VNÚTORNÁ PODPORA
- (EE) "O" SOONILISE RATTA TPELTLAAGER, SISETUGI
- (LT) DVIGUBAS RATO GUOLIS SU „O“ FORMOS GRIOVELIAIS, VIDINĖ ATRAMA
- (LV) "O" VEIDA PROFILA VĒLTŅA DIVRINDU GULTNIS, IEKŠĒJAIS BALSTS

- (CZ) KLADKA SPODNÍ POJEZDOVÁ „O“ PROFIL S VNITŘNÍ PODPĚROU DVOULOŽISKOVÁ
- (RO) RULMENȚI DUBLI CU ROTI DINȚATE ÎN FORMĂ DE „O“, SUPORT INTERN
- (HR) "O" ŽLJEBNI DVOSTRUKI LEŽAJ KOTAČA, UNUTRAŠNJI POTPORANJ
- (RUS) РОЛИК НИЖНИЙ, ПРОФИЛЬ «O», ДВУХПОДШИПНИКОВЫЙ, ВНУТРЕННЯЯ ОПОРА
- (SLO) TEKALNO KOLO Z "O" UTOROM Z DVEMA LEŽAJEMA, NOTRANJI PODPORNİK
- (TR) "O" YIVLİ TEKERLEKLI ÇİFT YATAK, İÇ DESTEK
- (AR) محمل مزدوج لعجلة مخددة على شكل حرف "O" دعامة داخلية
- (CHN) O槽轮双轴承, 内部支架
- (MAL) BEARING BERGANDA DENGAN RODA BERALUR "O", BANTUAN DALAM
- (H) O-HORNÝOS GÖRGŐ KÉT CSAPÁGGYAL, A GÖRGŐ A MEGTÁMASZTÁSBA SÜLLYED
- (IL) בית פתוח, מסב בודד O גלגל O
- (BG) РОЛКА С ДВОЕН ЛАГЕР ЗА "O"-ОБРАЗЕН ПРОФИЛ, ВЪТРЕШНА ПОДДЪРЪЖКА
- (KO) "O"자형 홈이 있는 휠 더블 베어링, 내부 지지대
- (SRB) TOČKIĆ SA „O“ ŽLEBOM I DVA LEŽAJA, UNUTRAŠNJI DRŽAČ

Art.	D1	D2	A	B	C	E	J	K	L	M	O	BEARING	CAPACITY	1pc		CODE	
														kg	pcs		kg
												mm					
WSO 824 B2	78	60	24	33	56	17	9x12	124	160	18	21	double	260	0,92	12	11,04	1700276
WSO 924 B2	88	70	24	33	61	17	9x12	124	160	18	21	double	280	1,13	12	13,56	1700277
WSO 1024 B2	98	80	24	33	66	17	9x12	124	160	18	21	double	300	1,37	10	13,7	1700278
WSO 1228 B2	118	100	28	39	83	18	9x12	150	190	20	21	double	360	2,37	6	14,22	1700279
WSO 1630 B2	158	140	30	44	116	20	11x16	210	250	20	21	double	480	4,95	2	9,9	1700280

RW

RR

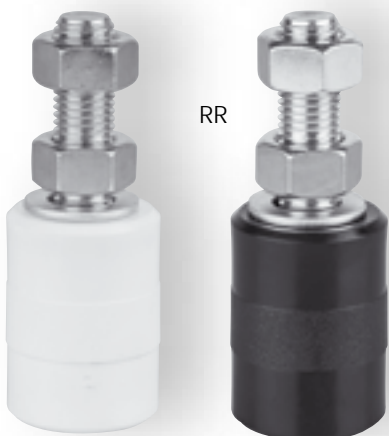

- (GB) NYLON GUIDE ROLLER
- (D) FÜHRUNGSROLLE
- (F) ROULEAU GUIDE EN NYLON
- (E) RODILLO DE GUÍA DE NYLON
- (P) ROLETE GUIA DE NYLON
- (I) RULLO PER GUIDA IN NYLON
- (DK) NYLON STYREVALSE
- (NL) NYLON GELEIDINGSROL
- (N) NYLON STYRERULLE
- (S) GEJDHJUL I NYLON
- (FIN) OHJAUSRULLA NAILONISTA
- (PL) ROLKA PROWADZĄCA NYLONOWA
- (SK) KLADKA HORNÁ VODIACA
- (EE) NAILONIST JUHTRULLIK
- (LT) NAILONINIS KREIPIAMASIS RITINĖLIS
- (LV) NEILONA VADRULLĪTIS

- (CZ) KLADKA HORNÍ VODÍČÍ
- (RO) ROLĂ GHIDAJ NYLON
- (HR) ROLICA OD NAJLONA
- (RUS) ВЕРХНИЙ НАПРАВЛЯЮЩИЙ ПОЛИМЕРНЫЙ РОЛИК
- (SLO) NAJLONSKO VODILNO KOLO
- (TR) NAYLON KIZAK SİLİNDİRİ
- (AR) بكرة دليلية مصنوعة من النايلون الأبيض
- (CHN) 白色尼龙导轮
- (MAL) PENGGULING PANDU NILON
- (H) NEJLON VEZETŐGÖRGŐ
- (IL) גלגל מוביל עליון אוקולון
- (BG) ПОЛИАМИДНА РОЛКА ЗА ВОДАЧ
- (KO) 나일론 가이드 롤러
- (SRB) VALJAK OD NAJLONA

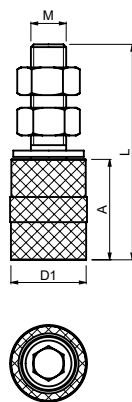



Art.	D1	A	L	M	1pc			CODE
						pcs	kg	
RW 26	26	40	82	M12	0,11	20	2,2	1700042
RW 30	31	40	87	M14	0,16	20	3,2	1700043
RW 40	40	55	108	M16	0,29	10	2,9	1700044
RR 26	26	40	82	M12	0,11	20	2,2	1700200
RR 30	31	40	87	M14	0,16	20	3,2	1700201
RR 40	40	55	108	M16	0,29	10	2,9	1700202

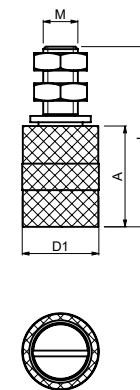

- (GB) NYLON GUIDE ROLLER
- (D) FÜHRUNGSROLLE
- (F) ROULEAU GUIDE EN NYLON
- (E) RODILLO DE GUÍA DE NYLON
- (P) ROLETE GUIA DE NYLON
- (I) RULLO PER GUIDA IN NYLON
- (DK) NYLON STYREVALSE
- (NL) NYLON GELEIDINGSROL
- (N) NYLON STYRERULLE
- (S) GEJDHJUL I NYLON
- (FIN) OHJAUSRULLA NAILONISTA
- (PL) ROLKA PROWADZĄCA NYLONOWA
- (SK) KLADKA HORNÁ VODIACA
- (EE) NAILONIST JUHTRULLIK
- (LT) NAILONINIS KREIPIAMASIS RITINĖLIS
- (LV) NEILONA VADRULLĪTIS

- (CZ) KLADKA HORNÍ VODÍČÍ
- (RO) ROLĂ GHIDAJ NYLON
- (HR) ROLICA OD NAJLONA
- (RUS) ВЕРХНИЙ НАПРАВЛЯЮЩИЙ ПОЛИМЕРНЫЙ РОЛИК
- (SLO) NAJLONSKO VODILNO KOLO
- (TR) NAYLON KIZAK SİLİNDİRİ
- (AR) بكرة دليلية مصنوعة من النايلون الأبيض
- (CHN) 白色尼龙导轮
- (MAL) PENGGULING PANDU NILON
- (H) NEJLON VEZETŐGÖRGŐ
- (IL) גלגל מוביל עליון אוקולון
- (BG) ПОЛИАМИДНА РОЛКА ЗА ВОДАЧ
- (KO) 나일론 가이드 롤러
- (SRB) VALJAK OD NAJLONA



Art.	D1	A	L	M	1pc			CODE
						pcs	kg	
RB 26	26	40	71	M12	0,13	20	2,6	1700046
RB 30	30	40	71	M14	0,16	20	3,2	1700222
RB 32	32	40	71	M14	0,16	20	3,2	1700047
RB 42/16	42	55	91	M16	0,35	10	3,5	1700337
RB 42/20	42	55	96	M20	0,4	10	4	1700048

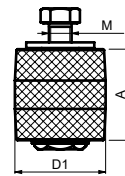

- (GB) NYLON GUIDE ROLLER
- (D) FÜHRUNGSROLLE
- (F) ROULEAU GUIDE EN NYLON
- (E) RODILLO DE GUÍA DE NYLON
- (P) ROLETE GUIA DE NYLON
- (I) RULLO PER GUIDA IN NYLON
- (DK) NYLON STYREVALSE
- (NL) NYLON GELEIDINGSROL
- (N) NYLON STYRERULLE
- (S) GEJDHJUL I NYLON
- (FIN) OHJAUSRULLA NAILONISTA
- (PL) ROLKA PROWADZĄCA NYLONOWA
- (SK) KLADKA HORNÁ VODIACA
- (EE) NAILONIST JUHTRULLIK
- (LT) NAILONINIS KREIPIAMASIS RITINĖLIS
- (LV) NEILONA VADRULLĪTIS

- (CZ) KLADKA HORNÍ VODÍČÍ
- (RO) ROLĂ GHIDAJ NYLON
- (HR) ROLICA OD NAJLONA
- (RUS) ВЕРХНИЙ НАПРАВЛЯЮЩИЙ ПОЛИМЕРНЫЙ РОЛИК
- (SLO) NAJLONSKO VODILNO KOLO
- (TR) NAYLON KIZAK SİLİNDİRİ
- (AR) بكرة نيلونية مصنوعة من النايلون الأبيض
- (CHN) 白色尼龙导轮
- (MAL) PENGGULING PANDU NILON
- (H) NEJLON VEZETŐGÖRGŐ
- (IL) גלגל מוביל עליון אנקולון
- (BG) ПОЛИАМИДНА РОЛКА ЗА ВОДАЧ
- (KO) 나일론 가이드 롤러
- (SRB) VALJAK OD NAJLONA

Art.	D1	A	M	1pc			CODE
					pcs	kg	
ROB 36	35	38	M10	0,14	20	2,8	1700045
ROB 48	48	48	M12	0,23	10	2,3	1700243
ROB 68	68	68	M12	0,46	4	1,84	1700338

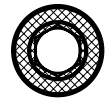
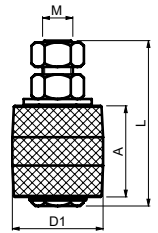

- (GB) NYLON GUIDE ROLLER
- (D) FÜHRUNGSROLLE
- (F) ROULEAU GUIDE EN NYLON
- (E) RODILLO DE GUÍA DE NYLON
- (P) ROLETE GUIA DE NYLON
- (I) RULLO PER GUIDA IN NYLON
- (DK) NYLON STYREVALSE
- (NL) NYLON GELEIDINGSROL
- (N) NYLON STYRERULLE
- (S) GEJDHJUL I NYLON
- (FIN) OHJAUSRULLA NAILONISTA
- (PL) ROLKA PROWADZĄCA NYLONOWA
- (SK) KLADKA HORNÁ VODIACA
- (EE) NAILONIST JUHTRULLIK
- (LT) NAILONINIS KREIPIAMASIS RITINĖLIS
- (LV) NEILONA VADRULLĪTIS

- (CZ) KLADKA HORNÍ VODÍČÍ
- (RO) ROLĂ GHIDAJ NYLON
- (HR) ROLICA OD NAJLONA
- (RUS) ВЕРХНИЙ НАПРАВЛЯЮЩИЙ ПОЛИМЕРНЫЙ РОЛИК
- (SLO) NAJLONSKO VODILNO KOLO
- (TR) NAYLON KIZAK SİLİNDİRİ
- (AR) بكرة نيلونية مصنوعة من النايلون الأبيض
- (CHN) 白色尼龙导轮
- (MAL) PENGGULING PANDU NILON
- (H) NEJLON VEZETŐGÖRGŐ
- (IL) גלגל מוביל עליון אנקולון
- (BG) ПОЛИАМИДНА РОЛКА ЗА ВОДАЧ
- (KO) 나일론 가이드 롤러
- (SRB) VALJAK OD NAJLONA

Art.	D1	A	L	M	1pc			CODE
						pcs	kg	
REB 36	35	38	72	M14	0,2	20	4	1700240
REB 48	48	48	88	M16	0,34	10	3,4	1700241
REB 68	68	68	108	M16	0,56	4	2,24	1700242



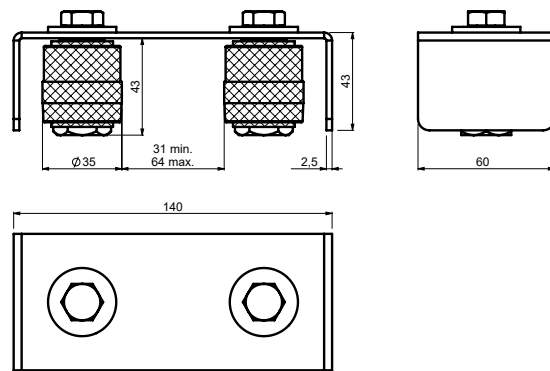

- (GB) TWO ROLLER GUIDE PLATE
- (D) OBERE FÜHRUNG MIT ZWEI ROLLEN, EINFACH REGULIERBAR
- (F) PLATINE GUIDE DEUX ROULEAUX
- (E) PLATO DE GUÍA DE RODILLO DOBLE
- (P) PLACA GUIA DE DOIS ROLETES
- (I) PIASTRA PER GUIDA A DUE RULLI
- (DK) STYREPLADE MED TO VALSER
- (NL) GELEIDINGSPLAAT DUBBELE ROLLER
- (N) STYREPLATE MED TO RULLER
- (S) GEJDPLATTA MED TVÅ RULLAR
- (FIN) KAKSI RULLAOHJAIMEN LEVYÄ
- (PL) PROWADNICA Z DWIEMA ROLKAMI
- (SK) VEDENIE BRÁNY HORNÉ S JEDNODUCHOU REGULÁCIOU, DVOJKLADKOVÉ
- (EE) KAHE RULLIKU JUHTPLAAT
- (LT) KREIPIAMOJI PLOKŠTĖ SU DVIEM RITINĖLIAIS
- (LV) DIVU VADRULLIŠU VIRZOŠĀ PLĀKSNE

- (CZ) VEDENÍ BRÁNY HORNÍ S JEDNODUCHOU REGULACÍ, DVOUKLADKOVÉ
- (RO) PLACĂ GHIDAJ CU DOUĂ ROLE
- (HR) VODEČA PLOČA S DVIJE ROLICE
- (RUS) ВЕРХНЯЯ НАПРАВЛЯЮЩАЯ СКОБА С ПРОСТЫМ РЕГУЛИРОВАНИЕМ, ДВА РОЛИКА
- (SLO) VODILNA PLOŠČA Z DVEMA KOLESOMA
- (TR) İKİ SİLİNDİRLİ KIZAK PLAKASI
- (AR) لوحة دليلية للكرة الثنائية
- (CHN) 双轮导板
- (MAL) PLAT PANDU DUA PENGUNGULING
- (H) KÉTGÖRGŐS VEZETŐLEMEZ
- (IL) עגלה מובילת עיניים שני אוקולון
- (BG) РОЛКОВ ВОДАЧ С ДВЕ РОЛКИ
- (KO) 이중 롤러 가이드판
- (SRB) VODEČA PLOČA SA DVA VALJKA

Art.	1pc		CODE
	kg	pcs	kg
SR 2	0,53	10	5,3

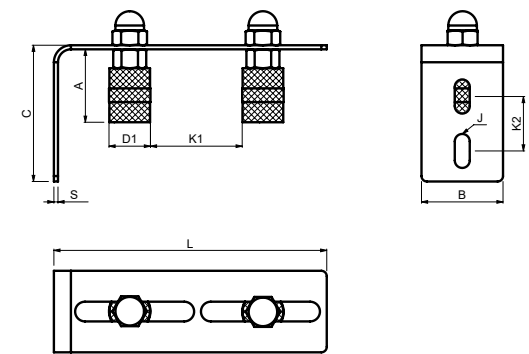

- (GB) TWO ROLLER GUIDE PLATE
- (D) OBERE FÜHRUNG MIT ZWEI ROLLEN, EINFACH REGULIERBAR
- (F) PLATINE GUIDE DEUX ROULEAUX
- (E) PLATO DE GUÍA DE RODILLO DOBLE
- (P) PLACA GUIA DE DOIS ROLETES
- (I) PIASTRA PER GUIDA A DUE RULLI
- (DK) STYREPLADE MED TO VALSER
- (NL) GELEIDINGSPLAAT DUBBELE ROLLER
- (N) STYREPLATE MED TO RULLER
- (S) GEJDPLATTA MED TVÅ RULLAR
- (FIN) KAKSI RULLAOHJAIMEN LEVYÄ
- (PL) PROWADNICA Z DWIEMA ROLKAMI
- (SK) VEDENIE BRÁNY HORNÉ S JEDNODUCHOU REGULÁCIOU, DVOJKLADKOVÉ
- (EE) KAHE RULLIKU JUHTPLAAT
- (LT) KREIPIAMOJI PLOKŠTĖ SU DVIEM RITINĖLIAIS
- (LV) DIVU VADRULLIŠU VIRZOŠĀ PLĀKSNE

- (CZ) VEDENÍ BRÁNY HORNÍ S JEDNODUCHOU REGULACÍ, DVOUKLADKOVÉ
- (RO) PLACĂ GHIDAJ CU DOUĂ ROLE
- (HR) VODEČA PLOČA S DVIJE ROLICE
- (RUS) ВЕРХНЯЯ НАПРАВЛЯЮЩАЯ СКОБА С ПРОСТЫМ РЕГУЛИРОВАНИЕМ, ДВА РОЛИКА
- (SLO) VODILNA PLOŠČA Z DVEMA KOLESOMA
- (TR) İKİ SİLİNDİRLİ KIZAK PLAKASI
- (AR) لوحة دليلية للكرة الثنائية
- (CHN) 双轮导板
- (MAL) PLAT PANDU DUA PENGUNGULING
- (H) KÉTGÖRGŐS VEZETŐLEMEZ
- (IL) עגלה מובילת עיניים שני אוקולון
- (BG) РОЛКОВ ВОДАЧ С ДВЕ РОЛКИ
- (KO) 이중 롤러 가이드판
- (SRB) VODEČA PLOČA SA DVA VALJKA

Art.	D1	L	A	B	C	J	K1	K2	S	1pc		CODE
										kg	pcs	kg
	mm											
FRS 2	31	200	51	60	100	11x25	0 - 134	40	3	0,64	6	3,9
FRM 2	40	260	67	75	130	13x30	0 - 160	60	4	1,32	4	6,04

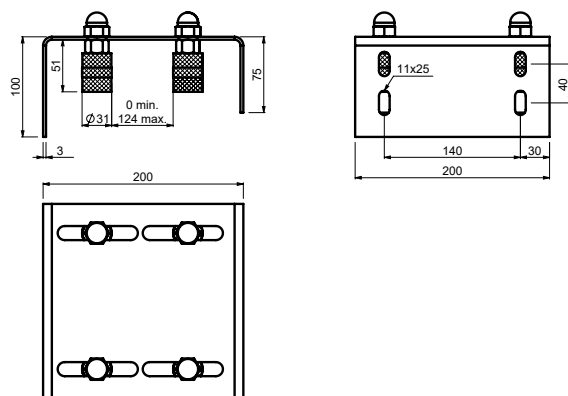

- (GB) ADJUSTABLE FOUR ROLLER GUIDE PLATE  
 (D) OBERE FÜHRUNG MIT VIER ROLLEN, DOPPELTE REGULIERUNG  
 (F) PLATINE GUIDE QUATRE ROULEAUX RÉGLABLE  
 (E) PLATO DE GUÍA AJUSTABLE DE CUATRO RODILLOS  
 (P) PLACA GUIA DE QUATRO ROLETES AJUSTÁVEL  
 (I) PIASTRA REGOLABILE PER GUIDA A QUATTRO RULLI  
 (DK) INDSTILLELIG STYREPLADE MED FIRE VALSER  
 (NL) INSTELBARE GELEIDINGSPLAAT VIERVOUDIGE ROLLER  
 (N) JUSTERBAR STYREPLATE MED FIRE RULLER  
 (S) JUSTERBAR GEJDPPLATTA MED FYRA RULLAR  
 (FIN) NELJÄ SÄÄDETTÄVÄÄ RULLAONJAIMEN LEVYÄ  
 (PL) REGULOWANA PROWADNICA Z CZTEREMA ROLKAMI  
 (SK) VEDENIE BRÁNY HORNÉ S DVOJITOU REGULÁCIU, ŠTVORKLADKOVÉ  
 (EE) REGULĒERITAV NELJA RULLIKU JUHTPLAAT  
 (LT) REGULIUOJAMA KREIPIAMOJI PLOKŠTĖ SU KETURIAIS RITINĖLIAIS  
 (LV) REGULĒJAMA ČETRU VADRULLIŠU VIRZOŠĀ PLĀKSNE

- (CZ) VEDENÍ BRÁNY HORNÍ S DVOJITOU REGULACÍ, ČTYŘKOLKOVÉ  
 (RO) PLACĂ REGLABILĂ DE GHIDAJ CU PATRU ROLÉ  
 (HR) PRILAGODLJIVA VODEĆA PLOČA S ČETIRI ROLICE  
 (RUS) ВЕРХНЯЯ НАПРАВЛЯЮЩАЯ СКОБА С ДВОЙНЫМ РЕГУЛИРОВАНИЕМ, ЧЕТЫРЕ РОЛИКА  
 (SLO) NASTAVLJIVA VODILNA PLOŠČA S ŠTIRIMI KOLESI  
 (TR) AYARLANABİLİR DÖRT SİLİNDİRLİ KIZAK PLAKASI  
 (AR) لوحة دليلية للكرة الرباعية قابلة للضبط  
 (CHN) 可调四轮导板  
 (MAL) PLAT PANDU EMPAT PENGUNGUNG BOLEH LARAS  
 (H) ÁLLÍTHATÓ NÉGYGÖRGÖS VEZETŐLEMEZ  
 (IL) עגלה מוביל עליון מתכווננת גודל 200  
 (BG) РЕГУЛИРУЕМ РОЛКОВ ВОДАЧ С ЧЕТИРИ РОЛКИ  
 (KO) 조절식 사중 롤러 가이드판  
 (SRB) PODESIVA VODEĆA PLOČA SA ČETIRI VALJKA

Art.	1pc				CODE
	kg	pcs	kg		
GRS 4	2,19	2	4,38		1700185

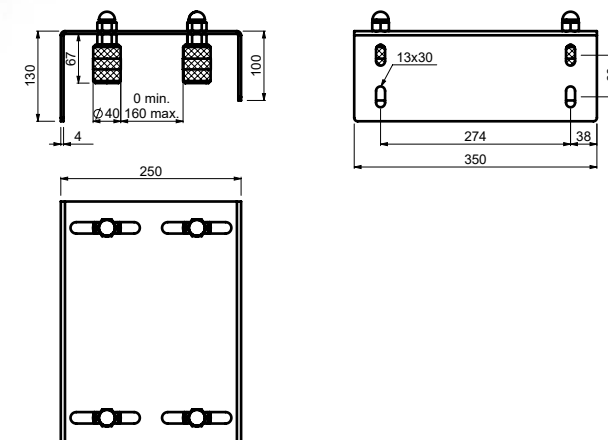

- (GB) ADJUSTABLE FOUR ROLLER GUIDE PLATE  
 (D) OBERE FÜHRUNG MIT VIER ROLLEN, DOPPELTE REGULIERUNG  
 (F) PLATINE GUIDE QUATRE ROULEAUX RÉGLABLE  
 (E) PLATO DE GUÍA AJUSTABLE DE CUATRO RODILLOS  
 (P) PLACA GUIA DE QUATRO ROLETES AJUSTÁVEL  
 (I) PIASTRA REGOLABILE PER GUIDA A QUATTRO RULLI  
 (DK) INDSTILLELIG STYREPLADE MED FIRE VALSER  
 (NL) INSTELBARE GELEIDINGSPLAAT VIERVOUDIGE ROLLER  
 (N) JUSTERBAR STYREPLATE MED FIRE RULLER  
 (S) JUSTERBAR GEJDPPLATTA MED FYRA RULLAR  
 (FIN) NELJÄ SÄÄDETTÄVÄÄ RULLAONJAIMEN LEVYÄ  
 (PL) REGULOWANA PROWADNICA Z CZTEREMA ROLKAMI  
 (SK) VEDENIE BRÁNY HORNÉ S DVOJITOU REGULÁCIU, ŠTVORKLADKOVÉ  
 (EE) REGULĒERITAV NELJA RULLIKU JUHTPLAAT  
 (LT) REGULIUOJAMA KREIPIAMOJI PLOKŠTĖ SU KETURIAIS RITINĖLIAIS  
 (LV) REGULĒJAMA ČETRU VADRULLIŠU VIRZOŠĀ PLĀKSNE

- (CZ) VEDENÍ BRÁNY HORNÍ S DVOJITOU REGULACÍ, ČTYŘKOLKOVÉ  
 (RO) PLACĂ REGLABILĂ DE GHIDAJ CU PATRU ROLÉ  
 (HR) PRILAGODLJIVA VODEĆA PLOČA S ČETIRI ROLICE  
 (RUS) ВЕРХНЯЯ НАПРАВЛЯЮЩАЯ СКОБА С ДВОЙНЫМ РЕГУЛИРОВАНИЕМ, ЧЕТЫРЕ РОЛИКА  
 (SLO) NASTAVLJIVA VODILNA PLOŠČA S ŠTIRIMI KOLESI  
 (TR) AYARLANABİLİR DÖRT SİLİNDİRLİ KIZAK PLAKASI  
 (AR) لوحة دليلية للكرة الرباعية قابلة للضبط  
 (CHN) 可调四轮导板  
 (MAL) PLAT PANDU EMPAT PENGUNGUNG BOLEH LARAS  
 (H) ÁLLÍTHATÓ NÉGYGÖRGÖS VEZETŐLEMEZ  
 (IL) עגלה מוביל עליון מתכווננת גודל 350  
 (BG) РЕГУЛИРУЕМ РОЛКОВ ВОДАЧ С ЧЕТИРИ РОЛКИ  
 (KO) 조절식 사중 롤러 가이드판  
 (SRB) PODESIVA VODEĆA PLOČA SA ČETIRI VALJKA

Art.	1pc				CODE
	kg	pcs	kg		
GRM 4	5,8	2	11,6		1700186



-  CUSTOMISED RUBBER RING PROTECTION
- NRB 70Sh** HIGH QUALITY RUBBER RING
-  CAIS INNOVATION

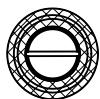
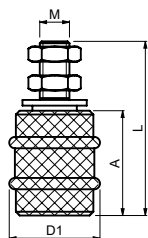

- GB** NYLON GUIDE ROLLER WITH SOFT RUBBER RING
- D** NYLONFÜHRUNGSROLLE MIT WEICHEM GUMMIRING
- F** ROULEAU DE GUIDAGE EN NYLON AVEC ANNEAU EN CAOUTCHOUC SOUPLE
- E** RODILLO GUÍA DE NYLON CON ANILLO DE CAUCHO BLANDO
- P** ROLO DE GUIA DE NYLON COM ANEL DE BORRACHA MACIA
- I** RULLO PER GUIDA IN NYLON CON ANELLO IN GOMMA MORBIDA
- DK** NYLON STYREVALSE MED BLØD GUMMIRING
- NL** NYLON GELEIDERROL MET ZACHTE RUBBEREN RING
- N** NYLON STYRERULLER MED MYK GUMMIRING
- S** GEJDRULLE I NYLON MED MJUK GUMMIRING
- FIN** NAILONOHJAUSRULLA PEHMEÄLLÄ KUMIRENKAALLA
- PL** ROLKA PROWADZĄCA NYLONOWA Z PIERŚCIENIEM Z MIĘKKIEJ GUMY
- SK** NYLONOVÝ VODIACI VALEC S MÄKKÝM GUMENÝM KRÚŽKOM
- EE** NAILONIST JUHTRULLIK PEHME KUMMIST RÕNGAGA
- LT** NAILONINIS KREIPIAMASIS RITINĖLIS SU MINKŠTU GUMINIU ŽIEDU
- LV** NEILONA VADRULLĪTIS AR MĪKSTU GUMIJAS GREZDZENU

- CZ** KLDKA HORNÍ VODÍČI S MĚKKÝM KROUŽKEM
- RO** ROLĂ DE GHIDAJ DIN NAILON CU GARNITURĂ DIN CAUCIUC MOALE
- HR** NAJLONSKI VODEČI VALJAK S MEKIM GUMENIM PRSTENOM
- RUS** ПОЛИМЕРНЫЙ НАПРАВЛЯЮЩИЙ РОЛИК С МЯГКИМ РЕЗИНОВЫМ КОЛЬЦОМ
- SLO** NAJLONSKI VODILNI VALJ Z MEHKIM GUMIJASTIM OBRČEM
- TR** YUMUŞAK LASTIK HALKALI NAYLON KILAVUZ MAKARASI
- AR** اسطوانة موجة النايلون ذات حلقة مطاطية ناعمة
- CHN** 配有软橡胶圈的尼龙导向辊
- MAL** PENGGELEK PANDU NILON DENGAN GELANG GETAH LEMBUT
- H** NEJLON VEZETŐGÖRGŐ PUHA GUMIGYŰRÜVEL
- IL** גלגל מוביל אייקול עם סביכות גומי
- BG** ПОЛИАМИДНА РОЛКА ЗА ВОДАЧ С МЕК ГУМЕН ПРЪСТЕН
- KO** 연성 고무 링이 있는 나일론 가이드 롤러
- SRB** VALJAK OD NAJLONA SA MEKIM GUMENIM PRSTENOM

Art.	D1	A	L	M	1pc			CODE
	∅					mm	kg	
SFB 42/16	48	55	91	M16	0,35	10	3,5	1700343



-  CUSTOMISED RUBBER RING PROTECTION
- NRB 70Sh** HIGH QUALITY RUBBER RING
-  CAIS INNOVATION

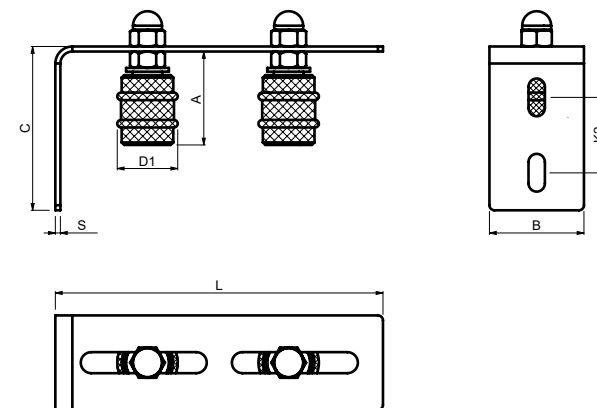

- GB** TWO ROLLER GUIDE PLATE WITH SOFT RUBBER RING
- D** FÜHRUNGSPLATTE MIT ZWEI ROLLEN UND WEICHEM GUMMIRING
- F** PLAQUE DE GUIDAGE À DEUX ROULEAUX AVEC ANNEAU EN CAOUTCHOUC SOUPLE
- E** PLACA GUIA DE DOS RODILLOS CON ANILLO DE CAUCHO BLANDO
- P** PLACA GUIA DE DOIS ROLOS COM ANEL DE BORRACHA MACIA
- I** PIASTRA PER GUIDA A DUE RULLI CON ANELLO IN GOMMA MORBIDA
- DK** STYREPLADE MED TO VALSER OG BLØD GUMMIRING
- NL** GELEIDINGSPLAAT TWEEVOLDIGE ROLLEN MET ZACHTE RUBBEREN RING
- N** TO-RULLE STYREPLATE MED MYK GUMMIRING
- S** GEJDRPLATTA MED TVÅ RULLAR MED MJUK GUMMIRING
- FIN** KAKSIRULLAINEN OHJAUSLEVY PEHMEÄLLÄ KUMIRENKAALLA
- PL** PROWADNICA Z DWIEMA ROLKAMI Z PIERŚCIENIEM Z MIĘKKIEJ GUMY
- SK** VODIACA DOSKA S DVOMA VALČEKMI, S MÄKKÝM GUMENÝM KRÚŽKOM
- EE** KAHE RULLIKUGA JUHTPLAAT PEHME KUMMIST RÕNGAGA
- LT** DVIJEJŲ RITINĖLIŲ KREIPIAMOJI PLOKŠTĖ SU MINKŠTU GUMINIU ŽIEDU
- LV** DIVU VADRULLIŠU VIRZOAŠ PLĀKSNE AR MĪKSTU GUMIJAS GREZDZENU

- CZ** VEDENÍ BRÁNY HORNÍ S JEDNODUCHOU REGULACÍ DVOUKLADKOVÉ S MĚKKÝM KROUŽKEM
- RO** PLACĂ DE GHIDAJ CU DOUĂ ROLE CU GARNITURĂ DIN CAUCIUC MOALE
- HR** DVIJE PLOČE VODILICE VALJKA S MEKIM GUMENIM PRSTENOM
- RUS** НАПРАВЛЯЮЩАЯ СКОБА, ДВА РОЛИКА, С МЯГКИМ РЕЗИНОВЫМ КОЛЬЦОМ
- SLO** VODILNA PLOŠČA Z DVEMA KOLESCEMA Z MEHKIM GUMIJASTIM OBRČEM
- TR** YUMUŞAK LASTIK HALKALI İKİ MAKARALI KILAVUZ PLAKASI
- AR** لوحا توجيه اسطوانتان ذات حلقة مطاطية ناعمة
- CHN** 配有软橡胶圈的双辊导向板
- MAL** DUA PLAT PANDU PENGGELEK DENGAN GELANG GETAH LEMBUT
- H** KÉT GÖRGŐS VEZETŐLEMEZ PUHA GUMIGYŰRÜVEL
- IL** 2 רולות מוביל עם סביכות גומי
- BG** РОЛКОВ ВОДАЧ С ДВЕ РОЛКИ С МЕК ГУМЕН ПРЪСТЕН
- KO** 연성 고무 링이 있는 이중 롤러 가이드판
- SRB** VODEČA PLOČA SA DVA VALJKA SA MEKIM GUMENIM PRSTENOM

Art.	D1	L	A	B	C	J	K1	K2	S	1pc			CODE
											mm	kg	
SFF 2M	48	260	72	75	130	13x30	0 - 150	60	4	1,56	4	6,24	1700344



-  CUSTOMISED RUBBER RING PROTECTION
- NRB 70Sh** HIGH QUALITY RUBBER RING
-  CAIS INNOVATION

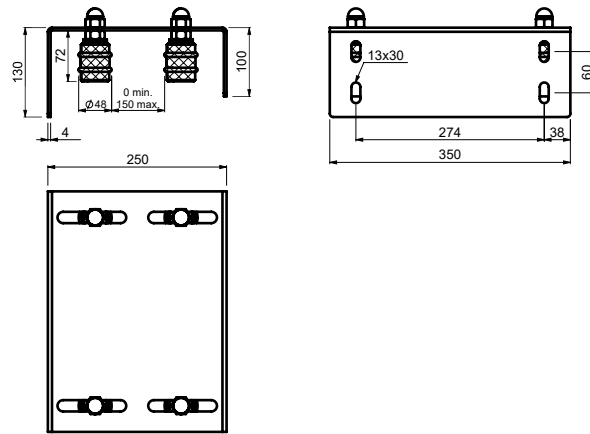

- (GB) ADJUSTABLE FOUR ROLLER GUIDE PLATE WITH SOFT RUBBER RING
- (D) EINSTELLBARE FÜHRUNGSPLATTE MIT VIER ROLLEN UND WEICHEM GUMMIRING
- (F) PLAQUE DE GUIDAGE À QUATRE ROULEAUX RÉGLABLES AVEC ANNEAU EN CAOUTCHOUC SOUPLE
- (E) PLACA GUÍA DE CUATRO RODILLOS AJUSTABLE CON ANILLO DE CAUCHO BLANDO
- (P) PLACA GUÍA DE QUATRO ROLOS COM ANEL DE BORRACHA MACIA
- (I) PIASTRA PER GUIDA A QUATTRO RULLI REGOLABILE CON ANELLO IN GOMMA MORBIDA
- (DK) INDSTILLELIG STYREPLADE MED FIRE VALSER OG BLØD GUMMIRING
- (NL) VERSTELBARE GELEIDINGSPLAAT VIEROVDIGE ROLLEN MET ZACHTE RUBBEREN RING
- (N) JUSTERBAR FIRERULLE STYREPLATE MED MYK GUMMIRING
- (S) JUSTERBAR GEJDPLATTA MED FYRA RULLAR MED MJUK GUMMIRING
- (FIN) SÄÄDETTÄVÄ NELIRULLAINEN OHJAUSLEVY PEHMEÄLLÄ KUMIRENKKAALLA
- (PL) REGULOWANA PROWADNICA Z CZTEREMA ROLKAMI Z MIĘKKIEJ GUMY
- (SK) NASTAVITEĽNÁ ŠTVORVALČEKOVÁ VODIACA DOSKA S MÄKKÝM GUMENÝM KRÚŽKOM
- (EE) REGULEERITAV NELJA RULLIKUGA JUHTPLAAT PEHME KUMMIST RÕNGAGA
- (LT) REGULIUOJAMA KETURIŲ RITINĖLIŲ KREPIAMOJI PLOKŠTE SU MINKŠTU GUMINIU ŽIEDU
- (LV) REGULĒJAMA ČETRU VADRULLIŠU VIRZOŠĀ PLĀKSNĒ AR MĪKŠTU GUMIJAS GREZDENU

- (CZ) VEDENÍ BRÁNY HORNÍ S DVOJITOU REGULACÍ ČTYŘKOLKOVÉ S MĚKKÝM KROUŽKEM
- (RO) PLACĂ REGLABILĂ DE GHIDAJ CU PATRU ROLE CU GARNITURĂ DIN CAUCIUC MOALE
- (HR) ČETIRI PRILAGODLJIVE PLOČE VODILICE VALJKA S MEKIM GUMENIM PRSTENOM
- (RUS) РЕГУЛИРУЕМАЯ НАПРАВЛЯЮЩАЯ СКОБА, ЧЕТЫРЕ РОЛИКА, С МЯГКИМ РЕЗИНОВЫМ КОЛЬЦОМ
- (SLO) NASTAVLJIVA VODILNA PLOŠČA S ŠTIRIMI KOLESCI Z MEHKIM GUMIJASTIM OBROČEM
- (TR) YUMUŞAK LASTIK HALKALI AYARLANABİLİR DÖRT MAKARALI KILAVUZ PLAKASI
- (AR) أربع لوحات توجيه اسطوانية قابلة للتعديل ذات حلقة مطاطية ناعمة
- (CHN) 配有软橡胶圈的可调节四辊导向板
- (MAL) EMPAT PLAT PANDU PENGGELEK BOLEH LARAS DENGAN GELANG GETAH LEMBUT
- (H) ÁLLÍTHATÓ NÉGYGÖRGÖS VEZETŐLEMEZ PUHA GUMIGYŰRŰVEL
- (IL) פלטת מוביל מתכוננת עם 4 גלגלים עם סביכות נמוכה
- (BG) РЕГУЛИРУЕМ РОЛКОВ ВОДАЧ С ЧЕТИРИ РОЛКИ С МЕК ГУМЕН ПРЪСТЕН
- (KO) 연성 고무 링이 있는 조절식 사중 롤러 가이드판
- (SRB) PODESIVA VODEČA PLOČA SA ČETIRI VALJKA SA MEKIM GUMENIM PRSTENOM

Art.	1pc		CODE
	kg	pcs	
SFG 4M	5,97	2	1700345

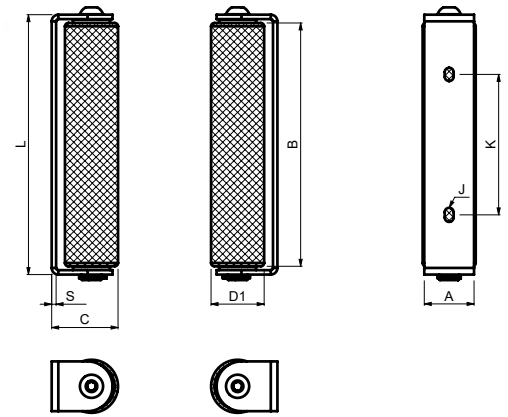

- (GB) ROLLER GUIDE PLATE FOR ARC SHAPE GATE
- (D) FÜHRUNGSPLATTE MIT ROLLE FÜR BOGENFÖRMIGES TOR
- (F) PLAQUE DE GUIDAGE DE ROULEAU POUR PORTE EN FORME D'ARC
- (E) PLACA GUÍA DE RODILLO PARA PORTÓN EN FORMA DE ARCO
- (P) PLACA DE GUÍA DE ROLOS PARA PORTÃO DE FORMA DE ARCO
- (I) PIASTRA PER GUIDA A RULLO PER CANCELLO AD ARCO
- (DK) VALSESTYREPLADE TIL BUEFORMET PORT
- (NL) GELEIDINGSPLAAT MET ROL VOOR BOOGVORMIGE POORT
- (N) RULLESTYRINGPLATE FOR BUEFORMET PORT
- (S) GEJDPLATTA MED RULLAR FÖR BÅGFORMIG GRIND
- (FIN) RULLAHOJAIMEN LEVY KAAREN MUOTOISEEN PORTTIIN
- (PL) PROWADNICA Z ROLKĄ DO BRAM LUKOWYCH
- (SK) VODIACA DOSKA S VALČEČKOM PRE BRÁNU TVARU OBLÚKA
- (EE) RULLIKU JUHTPLAAT KAAREKUUJULISE VÄRAVA JAOKS
- (LT) KREPIAMOJI PLOKŠTE SU RITINĖLIU ARKOS FORMOS VARTAMS
- (LV) VADRULLIŠU VIRZOŠĀ PLĀKSNĒ ARKVEIDA VĀRTIEM

- (CZ) VEDENÍ BRÁNY HORNÍ PRO OBLOUKOVÝ TVAR BRÁNY
- (RO) PLACĂ DE REGLAJ CU ROLE PENTRU PORTI ARCUITE
- (HR) PLOČA VODILICE VALJKA ZA VRATA U OBLIKU LUKA
- (RUS) НАПРАВЛЯЮЩАЯ СКОБА С РОЛИКОМ ДЛЯ АРОЧНЫХ ВОРОТ
- (SLO) VODILNA PLOŠČA S KOLESCI ZA VRATA V OBLIKU LOKA
- (TR) YAY ŞEKİLLİ KAPI İÇİN MAKARALI KILAVUZ PLAKASI
- (AR) لوحة توجيه اسطوانية لوزة قوسية الشكل
- (CHN) 弧形门辊子导向板
- (MAL) PLAT PANDU PENGGELEK UNTUK GET BENTUK ARKA
- (H) GÖRGÖS VEZETŐLEMEZ ÍVELT KAPUHOZ
- (IL) פלטת מוביל לגלגל לישער קשתית
- (BG) РОЛКОВ ВОДАЧ ЗА ПОРТА С ФОРМА НА АРКА
- (KO) 아크형 게이트용 롤러 가이드판
- (SRB) VODEČA PLOČA SA VALJKOM ZA KAPIJU LUČNOG OBLIKA

Art.	D1	L	A	B	C	J	K	S	1pc			CODE
									kg	pc	kg	
CRANKSHAFT 220	48	235	45	220	63	9x12	127	4	2,67	1	2,67	1700335
CRANKSHAFT 440	48	455	45	440	63	9x12	174	4	4,95	1	4,95	1700336

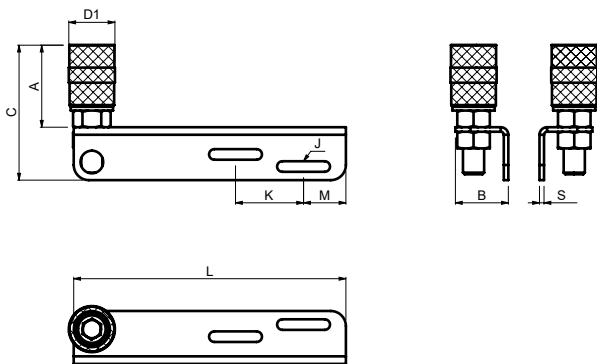

- (GB) SINGLE ROLLER GUIDE PLATE
- (D) FÜHRUNGSPLATTE MIT EINZELROLLE
- (F) PLAQUE DE GUIDAGE À UN SEUL ROULEAU
- (E) PLACA GUÍA DE RODILLO INDIVIDUAL
- (P) PLACA DE GUIA DE ROLO SIMPLES
- (I) PIASTRA PER GUIDA A RULLO SINGOLO
- (DK) STYREPLADE MED ENKELT VALSE
- (NL) GELEIDINGSPLAAT MET ENKELVOUDIGE ROL
- (N) ENKEL-RULL STYREPLATE
- (S) GEJDPLATTAN MED ENKELRULLE
- (FIN) YKSIRULLAINEN OHJAUSLEVY
- (PL) PROWADNICA Z JEDNĄ ROLKĄ
- (SK) JEDNOVALČEKOVÁ VODIACA DOSKA
- (EE) ÜKSIKU RULLIKU JUHTPLAAT
- (LT) KREIPIAMOJI PLOKŠTĖ SU VIENU RITINĖLIU
- (LV) VIENA VADRULLIŠA VIRZOŠĀ PLĀKSNE

- (CZ) VEDENÍ BRÁNY HORNÍ S JEDNODUCHOU REGULACÍ JEDNOKLADKOVÉ
- (RO) PLACĂ DE GHIDAJ CU O SINGURĂ ROLĂ
- (HR) JEDNOSTRUKA PLOČA VODILICE VALJKA
- (RUS) НАПРАВЛЯЮЩАЯ СКОБА, ОДИН РОЛИК
- (SLO) VODILNA PLOŠČA Z ENIM KOLESCEM
- (TR) TEK MAKARALI KILAVUZ PLAKASI
- (AR) لوحة توجيه السطوانة مفردة
- (CHN) 单辊导向板
- (MAL) PLAT PANDU PENGGELEK TUNGGAL
- (H) EGYGÖRGÖS VEZETŐLEMEZ
- (IL) פלטת מוביל לבלג אחד
- (BG) РОЛКОВ ВОДАЧ С ЕДНА РОЛКА
- (KO) 단일 롤러 가이드판
- (SRB) VODEČA PLOČA SA JEDNIM VALJKOM

Art.	D1	L	A	B	C	J	K	M	S	1pc	📦		CODE
											pcs	kg	
JRS 30	31	180	53	35	35	7x35	45	28	3	0,41	10	4,1	1700339
JRM 40	40	220	70	35	35	7x35	45	28	4	0,75	6	4,5	1700340

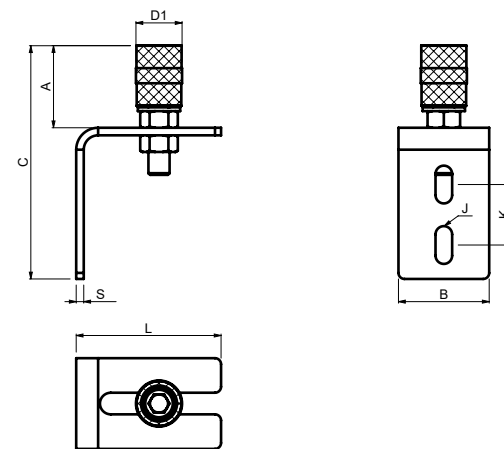

- (GB) SINGLE ROLLER GUIDE PLATE
- (D) FÜHRUNGSPLATTE MIT EINZELROLLE
- (F) PLAQUE DE GUIDAGE À UN SEUL ROULEAU
- (E) PLACA GUÍA DE RODILLO INDIVIDUAL
- (P) PLACA DE GUIA DE ROLO SIMPLES
- (I) PIASTRA PER GUIDA A RULLO SINGOLO
- (DK) STYREPLADE MED ENKELT VALSE
- (NL) GELEIDINGSPLAAT MET ENKELVOUDIGE ROL
- (N) ENKEL-RULL STYREPLATE
- (S) GEJDPLATTAN MED ENKELRULLE
- (FIN) YKSIRULLAINEN OHJAUSLEVY
- (PL) PROWADNICA Z JEDNĄ ROLKĄ
- (SK) JEDNOVALČEKOVÁ VODIACA DOSKA
- (EE) ÜKSIKU RULLIKU JUHTPLAAT
- (LT) KREIPIAMOJI PLOKŠTĖ SU VIENU RITINĖLIU
- (LV) VIENA VADRULLIŠA VIRZOŠĀ PLĀKSNE

- (CZ) VEDENÍ BRÁNY HORNÍ S JEDNODUCHOU REGULACÍ JEDNOKLADKOVÉ
- (RO) PLACĂ DE GHIDAJ CU O SINGURĂ ROLĂ
- (HR) JEDNOSTRUKA PLOČA VODILICE VALJKA
- (RUS) НАПРАВЛЯЮЩАЯ СКОБА, ОДИН РОЛИК
- (SLO) VODILNA PLOŠČA Z ENIM KOLESCEM
- (TR) TEK MAKARALI KILAVUZ PLAKASI
- (AR) لوحة توجيه السطوانة مفردة
- (CHN) 单辊导向板
- (MAL) PLAT PANDU PENGGELEK TUNGGAL
- (H) EGYGÖRGÖS VEZETŐLEMEZ
- (IL) פלטת מוביל לבלג אחד
- (BG) РОЛКОВ ВОДАЧ С ЕДНА РОЛКА
- (KO) 단일 롤러 가이드판
- (SRB) VODEČA PLOČA SA JEDNIM VALJKOM

Art.	D1	L	A	B	C	J	K	S	1 pc	📦		CODE
										pcs	kg	
PRS 30	31	95	53	60	153	11x25	40	5	0,54	10	5,4	1700341
PRM 40	40	105	70	75	170	13x30	40	5	0,87	6	5,22	1700342

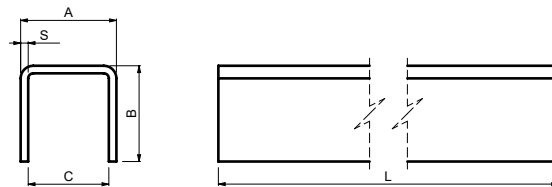
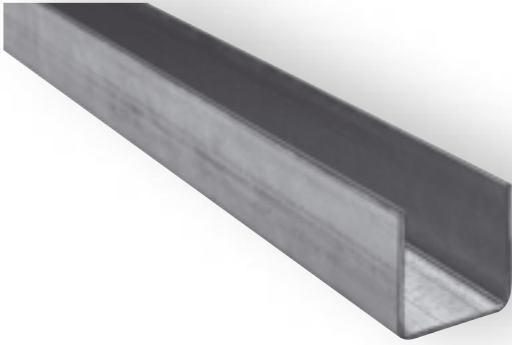

- (GB) „U“ PROFILE GUIDE FOR SLIDING AND CANTILEVER GATE  
 (D) „U“-PROFIL-FÜHRUNG FÜR SCHIEBE- UND AUSLEGERTOR  
 (F) GUIDE DE PROFIL EN „U“ POUR PORTAIL COULISSANT ET CANTILEVER  
 (E) GUÍA DE PERFIL EN „U“ PARA PORTÓN DESLIZANTE Y EN VOLADIZO  
 (P) GUIA DE PERFIL „U“ PARA PORTÃO DESLIZANTE E DE CANTILEVER  
 (I) GUIDA CON PROFILO A „U“ PER CANCELLO AUTOPORTANTE  
 (DK) „U“ PROFILVANGE TIL SKYDE OG FRITVÆRENDE PORT  
 (NL) „U“ PROFIELGELEIDER VOOR SCHUIVENDE POORT EEN SCHUIFPOORT  
 (N) „U“ PROFILSTYRING FOR SKYVE- OG RULLEPORT  
 (S) „U“ GEJDPROFIL FÖR SKJUTBAR GRIND OCH FRIBÄRANDE GRIND  
 (FIN) „U“-PROFILINEN OHJAIN LIUKU- JA ULOKEPORTTIIN  
 (PL) SZYNA O PROFILU „U“ DO BRAM PRZESUWNYCH I SAMONOSNYCH  
 (SK) VODIACA LIŠŤA V TVARE „U“ PRE POSUVNÚ A SAMONOSNÚ BRÁNU  
 (EE) „U“-PROFILLI JUHIK LIUG- JA KONSOOLVÄRAVA JAOKS  
 (LT) „U“ FORMOS PROFILIUOTAS KREIPTUVAS STUMDOMIESIEMS IR GEMBINIAM VARTAMS  
 (LV) „U“ VEIDA PROFILS BĪDĀMAJEM UN KONSOLVEIDA VĀRTIEM

- (CZ) ŠÍNA „U“ PROFIL PRO HORNÍ VEDENÍ BRÁNY  
 (RO) PROFIL DE GHIDAJ ÎN FORMĂ DE „U“ PENTRU PORȚI CULISANTE ȘI ÎN CONSOLĂ  
 (HR) „U“ PROFILNA VODILICA ZA KLIZNA I NOSIVA VRATA  
 (RUS) НАПРАВЛЯЮЩИЙ РЕЛЬС, ПРОФИЛЬ «U», ДЛЯ РАЗДВИЖНЫХ И САМОНЕСУЩИХ ВОРОТ  
 (SLO) „U“ VODILO ZA DRŠNA IN SAMONOSNA VRATA  
 (TR) SÜRGÜLÜ VE MANİVELA KAPLI İÇİN „U“ PROFİL YATAĞI  
 (AR) موجة القطار على شكل "U" القوية المتحركة والكامل  
 (CHN) 滑轨门和悬架门U型导向装置  
 (MAL) PANDU PROFIL "U" UNTUK GET GELONGSOR DAN JULUR  
 (H) U-VEZETŐSÍN TOLÓKAPUKHOZ  
 (IL) מנביל פרופיל U לשיער הדחה קונסול  
 (BG) „U“-ОБРАЗЕН ПРОФИЛ ЗА ПЛЪЗГАЩИ И КОНЗОЛНИ ВРАТИ  
 (KO) 슬라이딩 및 캔틸레버 게이트용 U자형 프로파일 가이드  
 (SRB) VOĐICA „U“ PROFILA ZA KLIZNU I SAMONOSIVU KAPIJU

“YOU HAVE TO LEARN  
 THE RULES OF THE GAME  
 AND THEN YOU HAVE  
 TO PLAY BETTER THAN  
 ANYONE ELSE”

– Albert Einstein –

Art.	L/1pc	A	B	C	S	ROLLER	1pc			CODE
								pcs	kg	
DRIVER 38/6	6000	38	38	32	3	PRS 30/JRM 30	14,7	56	823,2	1720092
DRIVER 38/3	3000	38	38	32	3	PRS 30/JRM 30	7,35	56	411,6	1720093
DRIVER 48/6	6000	48	48	42	3	PRS 40/JRM 40	18,9	42	793,8	1720089
DRIVER 48/3	3000	48	48	42	3	PRS 40/JRM 40	9,45	42	396,9	1720090

“QUALITY MEANS  
DOING IT RIGHT  
WHEN NO ONE IS LOOKING”

– Henry Ford



3D CAD Solutions and Rendering Software

PRODUCT DEVELOPMENT PROCESS  
CAIS PARTNER



ACCESSORIES FOR SLIDING AND SWING GATES

ACCESSORIES  CAIS



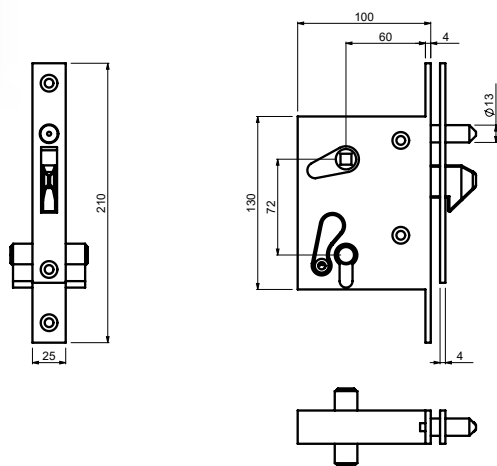

- (GB) HOOK LOCK FOR SLIDING GATES AND DOORS, WITH KEYS  
 (D) HAKENSCHLOSS MIT SCHLÜSSEL FÜR SCHIEBETOR  
 (F) SERRURE À CROCHET POUR PORTAILS ET PORTES COULISSANTES, AVEC CLÉS  
 (E) BLOQUEO DE GANCHO PARA PORTONES Y PUERTAS CORREDERAS, CON LLAVES  
 (P) TRAVA DE GANCHO PARA PORTÕES E PORTAS DESLIZANTES, COM CHAVES  
 (I) SERRATURA A GANCIO PER CANCELLI E PORTE SCORREVOLI, CON CHIAVI  
 (DK) HAGELÅS TIL SKYDEPORTE OG DØRE, MED NØGLER  
 (NL) HAAKSLLOT VOOR SCHUIFFPOORTEN EN DEUREN, MET SLEUTELS  
 (N) HAKELÅS FOR SKYVEPORTER OG -DØRER, MED NØKLER  
 (S) HAKLÅS FÖR SKJUTBARA GRINDAR OCH DÖRRAR, MED NYCKLAR  
 (FIN) KOUKKULUKKO LIUKUPOORTEIHIN JA -OVIIN, AVAIMILLA  
 (PL) ZAMEK Haczykowy do bram i drzwi przesuwanych z kluczami  
 (SK) ZÁMOK S KLÚČOM PRE POSUVNÚ BRÁNU A DVERE  
 (EE) KONKSULUKK LIUGVÁRAVATE JA -JSTE JAOKS, KOOS VÕTMETEGA  
 (LT) KABLIO TIPO UŽRAKTAS STUMDOMIESIEMS VARTAMS IR DURIMS SU RAKTAIS  
 (LV) SLĒDZENE AR ATSLĒGĀM BĪDĀMAJEM VĀRTIEM UN DURVĪM

- (CZ) ZÁMEK S KLÍČEM PRO POSUVNOU BRÁNU A VRATA  
 (RO) BROASCĂ CU CĂRLIG PENTRU PORTILE ȘI UȘILE GLISANTE, CU CHEI  
 (HR) BRAVA ZA KLIZNA DVORIŠNA I KUĆNA VRATA, S KLJUČEVIMA  
 (RUS) ЗАМОК С КЛЮЧОМ ДЛЯ ОТКАТНЫХ ВОРОТ  
 (SLO) KLJUČAVNICA ZA DRŠNA VRATA S KLJUČEM  
 (TR) SÜRGÜLÜ BAĞÇE KAPILARI VE KAPILAR İÇİN KANCA KİLİDİ, ANAHTARLI  
 (AR) قفل الحظاف الخاص بالوابت والزوارت المنزلقة، مع المفاتيح  
 (CHN) 滑动门钩锁，配钥匙  
 (MAL) KUNCI CANGKUK UNTUK PINTU PAGAR DAN PINTU GELONGSOR, DENGAN KEKUNCI  
 (H) NYELVES ZÁR TOLÓAJTÓKHOZ ÉS KAPUKHOZ, KULCSOKKAL  
 (IL) מנעול לשער או דלת הזזה עם צילינדר  
 (BG) БРАВА ЗА ПЛЪЗГАЩИ ПОРТИ И ВРАТИ, С КЛЮЧ  
 (KO) 슬라이딩 게이트 및 도어용 후크 잠금장치, 열쇠 포함  
 (SRB) BRAVA ZA KLIZNA DVORIŠNA I KUĆNA VRATA, SA KLJUČEVIMA



- (GB) END STOP FOR HOOK LOCK  
 (D) EINLAUF FÜR HAKENSCHLOSS  
 (F) BUTÉE POUR SERRURE À CROCHET  
 (E) TOPE FINAL PARA BLOQUEO DE GANCHO  
 (P) BATENTE PARA TRAVA DE GANCHO  
 (I) FERMO DI FINE CORSA PER SERRATURA A GANCIO  
 (DK) ENDESTOP TIL HAGELÅS  
 (NL) EINDSTOP VOOR HAAKSLLOT  
 (N) ENDESTOPPER FOR HAKELÅS  
 (S) ÄNDSTOPP FÖR HAKLÅS  
 (FIN) KOUKKULUKON PÄÄTYLUKKO  
 (PL) ODBOJNIK DO ZAMKA Haczykowego  
 (SK) DOJAZDOVÁ KAPSA PRE ZÁMOK S KLÚČOM  
 (EE) OTSALÕPP KONKSULUKU JAOKS  
 (LT) GALINIS RIBOKLIS KABLIO TIPO UŽRAKTUI  
 (LV) GALA AIZTŪRIS SLĒDZENĒI

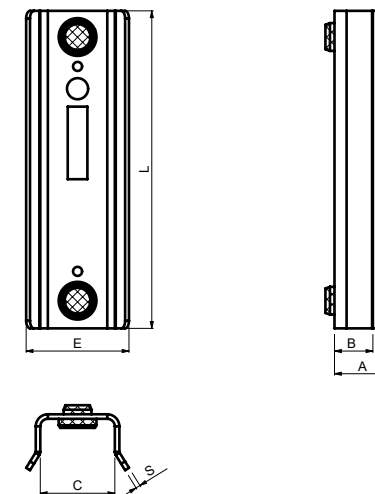

- (CZ) DOJAZDOVÁ KAPSA PRO ZÁMEK S KLÍČEM  
 (RO) OPRITOR CURSĂ PENTRU BROASCĂ CU CĂRLIG  
 (HR) GRANIČNIK ZA BRAVU  
 (RUS) УЛАВЛИВАТЕЛЬ ДЛЯ ЗАМКА С КЛЮЧОМ  
 (SLO) ZAUSTAVLJALNIK ZA KLJUČAVNICO ZA DRŠNA VRATA  
 (TR) KANCA KİLİDİ İÇİN UÇ TESPİT PARÇASI  
 (AR) ممانع طرفي القفل الحظافي  
 (CHN) 钩锁终端挡块  
 (MAL) PENYENDAL HUJUNG UNTUK KUNCI CANGKUK  
 (H) ÜTKÖZŐ NYELVES ZÁRHOZ  
 (IL) מנעול לשער או דלת הזזה עם צילינדר  
 (BG) КРАЕН ОГРАНИЧИТЕЛ ЗА БРАВА  
 (KO) 후크 잠금장치용 종단 장치대  
 (SRB) GRANIČNIK ZA BRAVU

Art.	1pc			CODE
	kg	pcs	kg	
LOCK L	1,26	5	6,3	1700053

Art.	C	L	A	B	E	S	1pc			CODE
							kg	pcs	kg	
mm										
DOCK 42	42	210	34	23	59	3	0,49	15	7,35	1700054
DOCK 52	52	210	37	26	68	3	0,58	10	5,8	1700055
DOCK 62	62	210	40	29	79	3	0,66	10	6,6	1700056

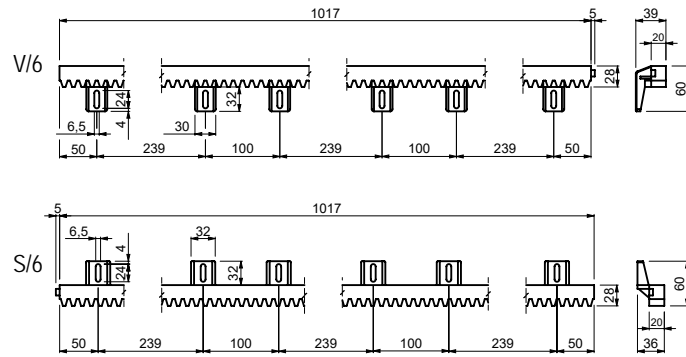

- (GB) MODULE 4 NYLON STEEL CORED RACK WITH FIXING SUPPORT
- (D) MODUL 4, NYLONZAHNSTANGE MIT STAHLKERN UND BEFESTIGUNGSTRÄGER
- (F) MODULE 4 CRÉMAILLÈRE NYLON AVEC CORPS EN ACIER ET SUPPORT DE FIXATION
- (E) MÓDULO DE BASE DE ACERO Y NYLON 4 CON SOPORTE DE FIJACIÓN INFERIOR
- (P) MÓDULO 4 DE PRATELEIRA DE BASE DE AÇO E NYLON COM SUPORTE DE FIXAÇÃO INFERIOR
- (I) RACK CON NUCLEO IN ACCIAIO MODULO 4 CON SUPPORTO DI FISSAGGIO
- (DK) MODUL 4 NYLONOPHÆNG MED STÅLKERNE MED FASTGØRELSESUNDERSTØTNING
- (NL) MODULE 4, KUNSTSTOF TANDLÄT MET STAALKERN, MET BEVESTIGING
- (N) MODUL 4 NYLON STÅLKJERNE STATIV MED FESTESTØTTE
- (S) MODUL 4 KUGGSTÅNG I NYLON MED STÅLKÄRNA MED FASTSÄTTNINGSTÖD
- (FIN) MODUULIN 4 TERÄSYTIMIEN NYLONKEHYS KIINNITYSTUELLA
- (PL) MODUL 4 NYLONOWA LISTWA ZEBATA ZE STALOWYM RDZENIEM ZE WSPORNIKIEM MOCUJĄCYM
- (SK) HREBEŇ NYLONOVÝ S OCELOVÝM JADROM, S FIXÁCIOU ZO SPODU, MODUL 4
- (EE) MODULI 4 NAILONIST TERASTUUMAGA RAAM FIKSEERIMISTOEGA
- (LT) 4 MODULIO NAILONINĖ PAKABA SU PLIENINE ŠERDIMI IR TVIRTINIMO ATRAMA
- (LV) MODULIS 4, NEILONA STATNIS AR TĒRAUDA SERDENI UN FIKSĒJOŠO BALSTENI

- (CZ) MODUL 4, NYLONOVÁ OZUBENÁ TYČ S OCELOVÝM JÁDREM S UPEVNŮVACÍ PODPĚROU
- (RO) MODUL 4 ȘINĂ DINȚATĂ ARMATĂ CU OȚEL, CU SUPORT DE FIXARE INFERIOR
- (HR) MODULARNA 4 NAJLONSKA ZUPČANA LETVA S ČELIČNOM JEZGROM I NOSAČEM ZA UGRADNJU
- (RUS) МОДУЛЬ 4, НЕЙЛОНОВАЯ ПОЛКА СО СТАЛЬНЫМ СЕРДЕЧНИКОМ И КРЕПЕЖНОЙ ОПОРОЙ
- (SLO) PLASTI ČNA ZOBATA LETEV Z JEKLENIM JEDROM IN SPODNJIM PODPORNikom ZA FIKSIRANJE, MODUL 4
- (TR) MODUL 4 NYLON ÇELİK ÖZLÜ İZGARA - SABİTLEMESTEĞİ İLE
- (AR) الوحدة \* المزودة برف فولادي من النايلون مع دعامة تثبيت
- (CHN) 帶固定板的模塊 4 尼龙涂层鋼齒條
- (MAL) RAK TERETAAS KELULI NILON 4 MODUL DENGAN SOKONGAN PENETAPAN
- (H) MODUL 4 NEJLON ACÉL MAGOS RACK RÖZÍTŐ TÁMASSZAL
- (IL) מודול 4, פוליאימידנה נאז'בנה אופרה סבס סטומאנהו יאדרו ופודפורי צא פיקסיראנה
- (BG) МОДУЛ 4, ПОЛИАМИДНА НАЗЪБЕНА ОПОРА СЪС СТОМАНЕНО ЯДРО И ПОДПОРИ ЗА ФИКСИРАНЕ
- (KO) 고정 지지대가 있는 모듈 4 나일론 강철심 락
- (SRB) MODULARNA 4 NAJLONSKA ZUPČASTA LETVA SA ČELIČNIM JEZGROM I NOSAČEM ZA UGRADNJU

Art.	1pc		CODE
	kg	pcs	
V/6	1,32	10	1700057
S/6	1,22	10	1700181

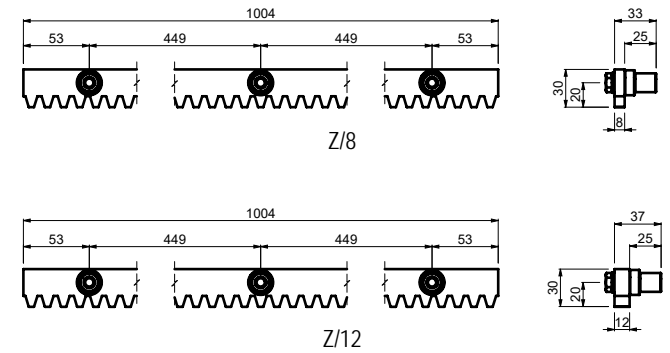

- (GB) MODULE 4 STEEL RACK WITH FIXING STAVES
- (D) EISENZAHNSTANGE MIT SCHRAUBEN, MODUL 4
- (F) MODULE 4 CRÉMAILLÈRES EN ACIER AVEC BOULONS DE FIXATION
- (E) MÓDULO DE BASE DE ACERO 4 CON PANELES DE FIJACIÓN
- (P) MÓDULO 4 - RACK DE AÇO COM SUPORTES DE FIXAÇÃO
- (I) MODULO 4 CREMAGLIERA IN ACCIAIO CON DOGHE DI FISSAGGIO
- (DK) MODUL 4 STÅLØPHÆNG MED FASTGØRELSESSTAVE
- (NL) MODULE 4 STALEN TANDLÄT MET BEVESTIGINGSSTAVEN
- (N) MODUL 4 TANNSTANG I STÅL MED FESTEBOLTER
- (S) MODUL 4 STÅLKUGGSTÅNG MED FÄSTSKRUVAR
- (FIN) MODUULIN 4 TERÄSKEHYS KIINNITYSOSILLA
- (PL) MODUL 4 STAŁOWA LISTWA ZEBATA ZE ŚRUBAMI MOCUJĄCYMI
- (SK) HREBEŇ KOVOVÝ S FIXAČNÝMI SKRUTKAMI, MODUL 4
- (EE) MODULI 4 TERASTUUMAGA RAAM FIKSEERIMISLAUDADEGA
- (LT) 4 MODULIO PLIENINĖ PAKABA SU TVIRTINIMO SKERSINIAIS
- (LV) MODULIS 4, TĒRAUDA STATNIS AR FIKSĒJOŠĀM SKRŪVĒM

- (CZ) HŘEBEN KOVOVÝ S FIXAČNÍMI ŠROUBY, MODUL 4
- (RO) MODUL 4 ȘINĂ DINȚATĂ CU ȘURUBURI DE FIXARE
- (HR) ČELIČNA ZUPČASTA GREDA SA ZAVRTNJI, MODUL 4
- (RUS) ЗУБЧАТАЯ РЕЙКА МЕТАЛЛИЧЕСКАЯ С КРЕПЕЖНЫМИ ВИНТАМИ, МОДУЛЬ 4
- (SLO) JEKLENA ZOBATA LETEV, MODUL 4, S PRITRDILNIMI VEZNIKI
- (TR) SABİTLEMESTEĞİ ÇUBUKLARIYLA MODUL 4 ÇELİK İZGARA
- (AR) الوحدة \* المزودة برف فولادي مع أطراف التثبيت
- (CHN) 模塊4鋼齒條，配固定杆
- (MAL) RAK KELULI 4 MODUL DENGAN PALANG PENETAP
- (H) MODUL 4, ACÉL FOGASLÉC RÖGZÍTŐCSAVAROKKAL
- (IL) סבס שטיימ מחתק מ"מ 12 עם בולטות
- (BG) МОДУЛ 4, СТОМАНЕНА НАЗЪБЕНА ОПОРА С ФИКСИРАЦИ БОЛТОВЕ
- (KO) 고정 통널이 있는 모듈 4 강철 락
- (SRB) MODULARNA 4 ČELIČNA ZUPČASTA LETVA SA ZAVRTNJI, MODUL 4

Art.	1pc		CODE
	kg	pcs	
Z/8	1,73	10	1700058
Z/12	2,53	10	1700193

ungalvanized

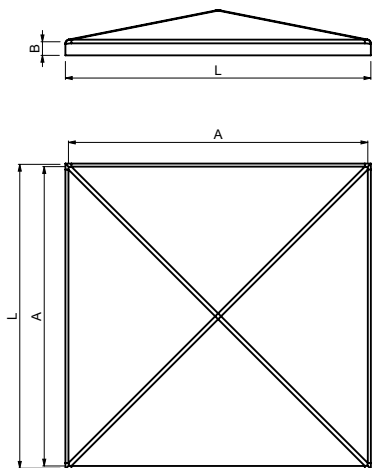
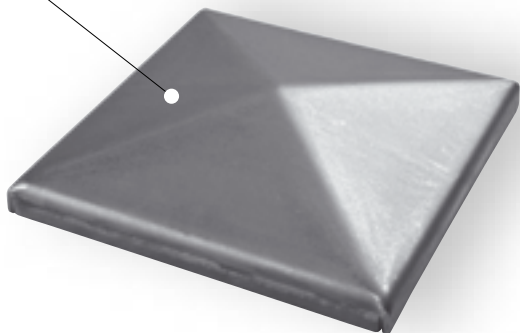

- (GB) SQUARE CAP FOR COLUMN, UNGALVANIZED
- (D) ABDECKKAPPE FÜR STEHER, ROH
- (F) COUVRE-PILIER CARRÉ, NON GALVANISÉ
- (E) TOPE CUADRADO PARA COLUMNA, SIN GALVANIZAR
- (P) TAMPA QUADRADA PARA COLUNA, NÃO GALVANIZADA
- (I) COPERTURA SQUADRATA PER MONTANTE, NON GALVANIZZATO
- (DK) FIRKANTET DÆKSEL TIL SØJLE, IKKE GALVANISERET
- (NL) VIERKANTE KAP VOOR KOLOM, ONVERZINKT
- (N) FIRKANTBESLAG TIL SØYLER, UGALVANISERT
- (S) FYRKANTIG HUV FÖR STOLPE, O GALVANISERAD
- (FIN) NELIKULMAINEN KANSI Pylvääseen, SINKITTÄMÄTÖN
- (PL) KWADRATOWA ZAŚLEPKA SŁUPKA, NIEOCYNKOWANA
- (SK) ZÁSLEPKA ŠTVORCOVÁ PRE STĽPIK, ČIERNÁ
- (EE) RUUDUKUJULINE KORK SAMBA JAOKS, GALVANISEERIMATA
- (LT) KVADRATINIS DANGTELIS STULPUI, NECINKUOTAS
- (LV) KVADRĀTVEIDA UZGALIS STABAM, NEGALVANIZĒTS

- (CZ) ZÁSLEPKA ČTVERCOVÁ PRO SLOUPEK, ČERNÁ
- (RO) ACOPERIRE PĂTRATĂ PENTRU COLOANĂ, NEGALVANIZATĂ
- (HR) ČETVRTASTI ČEP ZA STUPOVE, NEGALVANIZIRANI
- (RUS) ЗАГЛУШКА ДЛЯ СТОЛБА КВАДРАТНАЯ, ЧЕРНАЯ
- (SLO) PRAVOKOTNA KAPICA ZA STEBRICEK, NEPOCINKANA
- (TR) SÜTÜN İÇİN KARE LASTİK, GALVANİZLENMEMİŞ
- (AR) غطاء مربع العمود غير مغلف
- (CHN) 立柱方盖, 非镀锌
- (MAL) PENUTUP SEGI EMPAT SAMA UNTUK TIANG, TIDAK TERGALVANI
- (H) NÉGYZET ALAKÚ LEZÁRÓ-ELEM OSZLOPHOZ, NEM GALVANIZÁLT
- (IL) מכסה קצה פרופיל מרובע לא מגולן
- (BG) КВАДРАТНА КАПАНКА ЗА КОЛОНА, НЕПОЦИНКОВАНА
- (KO) 기둥용 사각 캡, 아연 도금 없음
- (SRB) ČETVRTASTA KAPICA ZA STUBOVE, NEGALVANIZOVANA

Art.	A	L	B	1pc	Image		CODE
					pcs	kg	
mm							
ROOF 3B	31	35	7	0,028	100	2,8	1700059
ROOF 4B	41	45	7	0,045	100	4,5	1700060
ROOF 5B	51	55	7	0,055	100	5,5	1700061
ROOF 6B	61	65	7	0,085	50	4,25	1700062
ROOF 8B	81	85	7	0,13	50	6,5	1700063
ROOF 10B	101	105	7	0,19	40	7,6	1700064
ROOF 12B	121	125	8	0,2	20	4	1700065
ROOF 15B	151	155	9	0,27	10	2,7	1700066
ROOF 20B	201	205	10	0,73	8	5,84	1700067

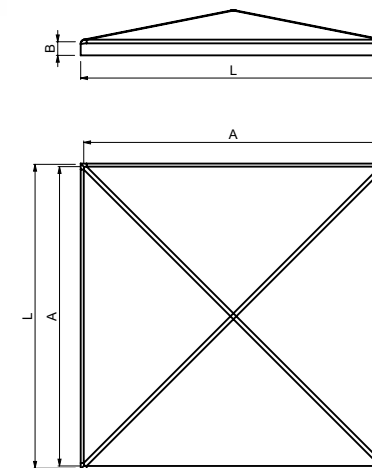
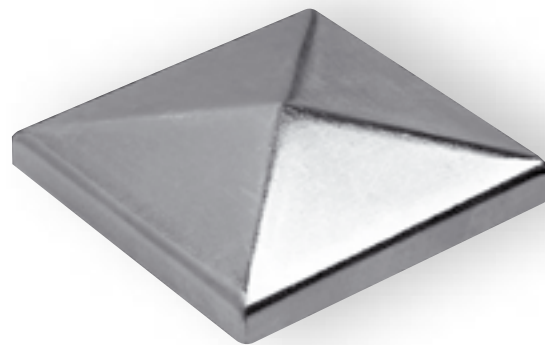

- (GB) SQUARE CAP FOR COLUMN, GALVANIZED
- (D) ABDECKKAPPE FÜR STEHER, VERZINKT
- (F) COUVRE-PILIER CARRÉ, GALVANISÉ
- (E) TOPE CUADRADO PARA COLUMNA, GALVANIZADO
- (P) TAMPA QUADRADA PARA COLUNA, GALVANIZADA
- (I) COPERTURA SQUADRATA PER MONTANTE, GALVANIZZATO
- (DK) FIRKANTET DÆKSEL TIL SØJLE, GALVANISERET
- (NL) VIERKANTE KAP VOOR KOLOM, VERZINKT
- (N) FIRKANTBESLAG TIL SØYLER, GALVANISERT
- (S) FYRKANTIG HUV FÖR STOLPE, GALVANISERAD
- (FIN) NELIKULMAINEN KANSI Pylvääseen, SINKITTY
- (PL) KWADRATOWA ZAŚLEPKA SŁUPKA, OCYNKOWANA
- (SK) ZÁSLEPKA ŠTVORCOVÁ PRE STĽPIK, POZINK
- (EE) RUUDUKUJULINE KORK SAMBA JAOKS, GALVANISEERITUD
- (LT) KVADRATINIS DANGTELIS STULPUI, CINKUOTAS
- (LV) KVADRĀTVEIDA UZGALIS STABAM, GALVANIZĒTS

- (CZ) ZÁSLEPKA ČTVERCOVÁ PRO SLOUPEK, POZINK
- (RO) ACOPERIRE PĂTRATĂ PENTRU COLOANĂ, GALVANIZATĂ
- (HR) ČETVRTASTI ČEP ZA STUPOVE, GALVANIZIRANI
- (RUS) ЗАГЛУШКА ДЛЯ СТОЛБА КВАДРАТНАЯ, ОЦИНКОВАННАЯ
- (SLO) PRAVOKOTNA KAPICA ZA STEBRICEK, POCINKANA
- (TR) SÜTÜN İÇİN KARE LASTİK, GALVANİZLENMİŞ
- (AR) غطاء مربع العمود مغلف
- (CHN) 立柱方盖, 镀锌
- (MAL) PENUTUP SEGI EMPAT SAMA UNTUK TIANG, TERGALVANI
- (H) NÉGYZET ALAKÚ LEZÁRÓ-ELEM OSZLOPHOZ, GALVANIZÁLT
- (IL) מכסה קצה פרופיל מרובע מגולן
- (BG) КВАДРАТНА КАПАНКА ЗА КОЛОНА, ПОЦИНКОВАНА
- (KO) 기둥용 사각 캡, 아연 도금 있음
- (SRB) ČETVRTASTA KAPICA ZA STUBOVE, GALVANIZOVANA

Art.	A	L	B	1pc	Image		CODE
					pcs	kg	
mm							
ROOF 3S	31	35	7	0,028	100	2,8	1700068
ROOF 4S	41	45	7	0,045	100	4,5	1700069
ROOF 5S	51	55	7	0,055	100	5,5	1700070
ROOF 6S	61	65	7	0,085	50	4,25	1700071
ROOF 8S	81	85	7	0,13	50	6,5	1700072
ROOF 10S	101	105	7	0,19	40	7,6	1700073
ROOF 12S	121	125	8	0,2	20	4	1700074
ROOF 15S	151	155	9	0,27	10	2,7	1700075
ROOF 20S	201	205	10	0,73	8	5,84	1700076

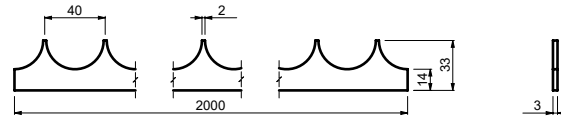
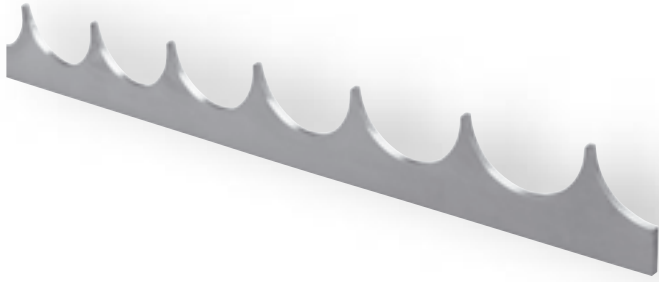

- (GB) SAFETY BAR, WELDED
- (D) SICHERHEITSTANGE, GESCHWEIßT
- (F) BARRE DE SÉCURITÉ, SOUDÉE
- (E) BARRA DE SEGURIDAD, SOLDADA
- (P) BARRA DE SEGURANÇA, SOLDADA
- (I) BARRA DI SICUREZZA, SALDATA
- (DK) SIKKERHEDSSTANG, SVEJSET
- (NL) VEILIGHEIDSBALK, GELAST
- (N) SIKKERHETSSTANG, SVEISET
- (S) SÄKERHETSSENA, SVETSAD
- (FIN) TURVATANKO, HITSATTU
- (PL) LISTWA ZABEZPIECZAJĄCA, SPAWANA
- (SK) BEZPEČNOSTNÁ TYČ, ZVÁRANÁ
- (EE) OHUTUSTALA, KEEVITATUD
- (LT) SAUGOS SKERSINIS, SUVIRINTAS
- (LV) DROŠĪBAS STIENIS, METINĀTS

- (CZ) BEZPEČNOSTNÍ LIŠTA, K PŘIVAŘENÍ
- (RO) BARĂ DE SIGURANȚĂ, SUDATĂ
- (HR) SIGURNOSNA ŠIPKA, ZAVARENA
- (RUS) ПРЕДОХРАНИТЕЛЬНЫЙ СТЕРЖЕНЬ, СВАРНОЙ
- (SLO) VARNOSTNI VZVOD, VARJEN
- (TR) EMNİYET ÇUBUĞU, KAYNAKLI
- (AR) قضيب السلامة، ملحوم
- (CHN) 安全杆 (焊接)
- (MAL) BAR KESELAMATAN, BERKIMPAL
- (H) BIZTOSÍTÓRÚD, HEGESZTETT
- (IL) מוט בטיחות, מותך
- (BG) ПРЕДПАЗЕН ДЪРЖАЧ, ЗАВАРЕН
- (KO) 안전대, 용접식
- (SRB) SIGURNOSNA ŠIPKA, UGRADNJA ZAVARIVANJEM

Art.	1pc		CODE
	kg	pc	
DUNE 2	0,84	1	1700234

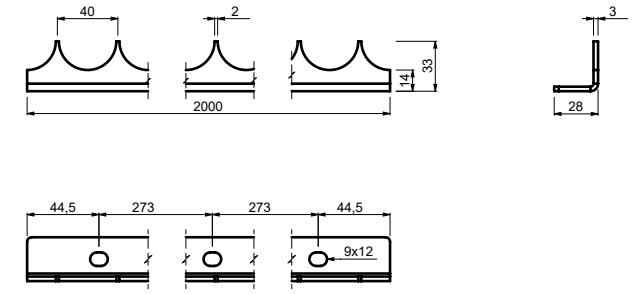

- (GB) SAFETY BAR, FIXED
- (D) SICHERHEITSTANGE, FEST
- (F) BARRE DE SÉCURITÉ, SOUDÉE
- (E) BARRA DE SEGURIDAD, FIJADA
- (P) BARRA DE SEGURANÇA, FIXADA
- (I) BARRA DI SICUREZZA, FISSA
- (DK) SIKKERHEDSSTANG, FASTGJORT
- (NL) VEILIGHEIDSBALK, VASTGESCHROEFD
- (N) SIKKERHETSSTANG, FAST
- (S) SÄKERHETSSENA, FAST
- (FIN) TURVATANKO, PYSYVÄ
- (PL) LISTWA ZABEZPIECZAJĄCA, MOCOWANA
- (SK) BEZPEČNOSTNÁ TYČ, PEVNÁ
- (EE) OHUTUSTALA, FIKSEERITUD
- (LT) SAUGOS SKERSINIS, PRITVIRTINTAS
- (LV) DROŠĪBAS STIENIS, FIKSETS

- (CZ) BEZPEČNOSTNÍ LIŠTA, K PŘÍŠROBOVÁNÍ
- (RO) BARĂ DE SIGURANȚĂ, FIXĂ
- (HR) SIGURNOSNA ŠIPKA, FIKSIRANA
- (RUS) ПРЕДОХРАНИТЕЛЬНЫЙ СТЕРЖЕНЬ, ПРИКРУЧИВАНИЕ ВИНТАМИ
- (SLO) VARNOSTNI VZVOD, FIKSIRAN
- (TR) EMNİYET ÇUBUĞU, SABIT
- (AR) قضيب السلامة، مثبت
- (CHN) 安全杆 (固定式)
- (MAL) BAR KESELAMATAN, BERIKAT
- (H) BIZTOSÍTÓRÚD, RÖGZÍTETT
- (IL) מוט בטיחות, קבוע
- (BG) ПРЕДПАЗЕН ДЪРЖАЧ, ФИКСИРАН
- (KO) 안전대, 고정식
- (SRB) SIGURNOSNA ŠIPKA, UGRADNJA ZAVRTNJIMA

Art.	1pc		CODE
	kg	pc	
DUNE 2L	1,87	1	1700235

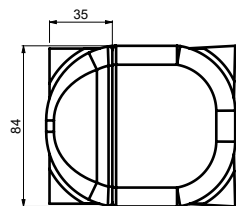
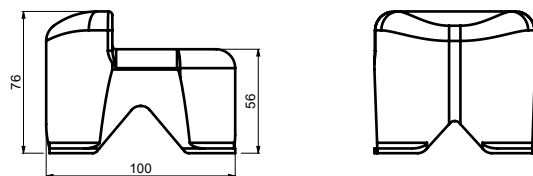

- (GB) END STOP, CONCRETED, FOR WING GATES  
 (D) BODENANSCHLAG FÜR DREHTORE ZUM EINBETONIEREN  
 (F) BUTÉE, BÉTONNÉE, POUR PORTAILS À VANTAUX  
 (E) TOPE FINAL, ENCOFRADO, PARA PUERTAS BATIENTES  
 (P) BATEANTE, CONCRETADO, PARA PORTÕES DE FOLHA  
 (I) FERMO DI FINE CORSA, CEMENTATO, PER CANCELLI A BATTENTE  
 (DK) ENDESTOP, STØBT I BETON, TIL FLØJPORTE  
 (NL) EINDSTOP, GESTORT IN BETON, VOOR DRAAIPOORTEN  
 (N) ENDESTOPPER, BETONGEFESTET, FOR SVINGPORTER  
 (S) ÄNDSTOPP, CEMENTERAT, FÖR SKJUTBARA SLAGGRINDAR  
 (FIN) PÄÄTYPYSÄYTIN, BETONIRAKENTEELLA, ETEEN- JA TAAKSEPÄIN AVAUTUVIIN PORTEIHIIN  
 (PL) OGRANICZNIK, ZALEWANY W BETONIE, DO BRAM SKRZYDŁOWYCH  
 (SK) DORAZ SPODNÝ PRE KRÍDLOVÝ BRÁNU, K ZABETÓNOVANIU  
 (EE) OTSALÕPP, BETONISEERITUD, TIIBVÄRAVATE JAOKS  
 (LT) GALINIS RIBOKLIS, BETONUOTAS, ATVERIAMIEMS VARTAMS  
 (LV) GALAAIZTURIS, BETONĒTS, VERAMAJIEM VĀRTIEM

- (CZ) DORAZ SPODNÍ PRO KŘÍDLOVOU BRÁNU, K ZABETONOVÁNÍ  
 (RO) OPRITOR CURSĂ, CIMENTAT, PENTRU UȘILE GLISANTE  
 (HR) GRANIČNIK, UGRADNJA BETONIRANJEM, ZA KRILNA DVORIŠNA VRATA  
 (RUS) НИЖНИЙ УПОР ДЛЯ РАСПЯШНЫХ ВОРОТ, ЦЕМЕНТИРОВАНИЕ  
 (SLO) ZAUSTAVLJALNIK, ZA PRITRDITEV Z BETONIRANJEM, ZA KRILNA VRATA  
 UÇ TESPİT PARÇASI, BETONLA SABİTLENMİŞ,  
 (TR) KANATLI BAHÇE KAPILARI İÇİN  
 (AR) ممانع طرفي، مثبتة، للوابواب الجانحية  
 (CHN) 平开门混凝土终点挡块  
 (MAL) PENYENDAL HUJUNG, KONKRIT, UNTUK PINTU PAGAR AYUN  
 (H) ÜTKÖZŐ, BETONBA ÁGYAZOTT, SZÁRNYAS KAPUKHOZ  
 (IL) מעצור תחתון צר לשיער כנפים לצידקה  
 (BG) СТОПЕР, БЕТОНЕН, ЗА ПОРТИ С КРИЛА  
 (KO) 종단 정지대, 콘크리트식, 옆 게이트용  
 (SRB) GRANIČNIK, UGRADNJA BETONIRANJEM, ZA KRILNA DVORIŠNA VRATA

Art.	1pc			CODE
	kg	pcs	kg	
LIMIT	0,33	6	1,98	1700077

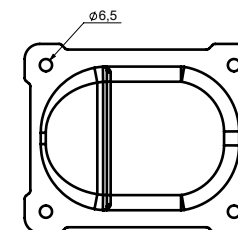
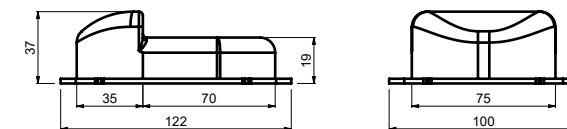
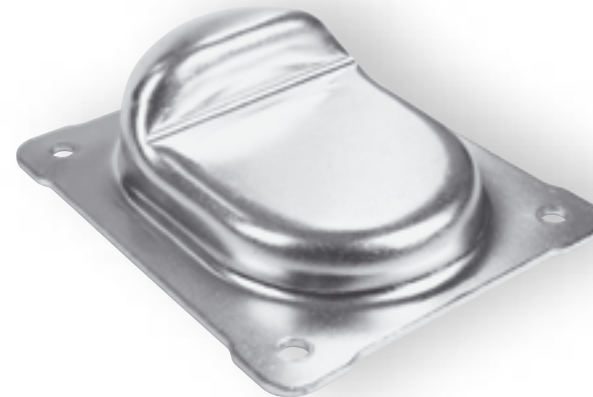

- (GB) END STOP, FIXED, FOR WING GATES  
 (D) BODENANSCHLAG FÜR DREHTORE ZUM VERSCHRAUBEN  
 (F) BUTÉE, FIXÉE, POUR PORTAILS À VANTAUX  
 (E) TOPE FINAL, FIJO, PARA PUERTAS BATIENTES  
 (P) BATEANTE, FIXO, PARA PORTÕES DE FOLHA  
 (I) FERMO DI FINE CORSA, FISSA, PER CANCELLI A BATTENTE  
 (DK) ENDESTOP, FAST, TIL FLØJPORTE  
 (NL) EINDSTOP, VASTGESCHROEFD, VOOR DRAAIPOORTEN  
 (N) ENDESTOPPER, FAST, FOR SVINGPORTER  
 (S) ÄNDSTOPP, FAST, FÖR SLAGGRINDAR  
 (FIN) PÄÄTYPYSÄYTIN, PYSYVÄ, ETEEN- JA TAAKSEPÄIN AVAUTUVIIN PORTEIHIIN  
 (PL) OGRANICZNIK, PRZYKRĘCANY, DO BRAM SKRZYDŁOWYCH  
 (SK) DORAZ SPODNÝ PRE KRÍDLOVÝ BRÁNU, K PRISKRUTKOVANIU  
 (EE) OTSALÕPP, FIKSEERITUD, TIIBVÄRAVATE JAOKS  
 (LT) GALINIS RIBOKLIS, FIKSUOTAS, ATVERIAMIEMS VARTAMS  
 (LV) GALAAIZTURIS, FIKSĒTS, VERAMAJIEM VĀRTIEM

- (CZ) DORAZ SPODNÍ PRO KŘÍDLOVOU BRÁNU, K PŘÍŠROBOVÁNÍ  
 (RO) OPRITOR CURSĂ, FIX, PENTRU UȘILE GLISANTE  
 (HR) GRANIČNIK, UGRADNJA ZAVRTNJIMA, ZA KRILNA DVORIŠNA VRATA  
 (RUS) НИЖНИЙ УПОР ДЛЯ РАСПЯШНЫХ ВОРОТ, ПРИКРУЧИВАНИЕ ВИНТАМИ  
 (SLO) ZAUSTAVLJALNIK, ZA PRIVITJE Z VIJAKI, ZA KRILNA VRATA  
 (TR) UÇ TESPİT PARÇASI, SABİT, KANATLI BAHÇE KAPILARI İÇİN  
 (AR) ممانع طرفي، مثبتة، للوابواب الجانحية  
 (CHN) 平开门固定式终点挡块  
 (MAL) PENYENDAL HUJUNG, TETAP, UNTUK PINTU PAGAR AYUN  
 (H) ÜTKÖZŐ, RÖGZÍTETT, SZÁRNYAS KAPUKHOZ  
 (IL) מעצור תחתון צר לשיער כנפים התקנה בעיגון  
 (BG) СТОПЕР, ФИКСИРАН, ЗА ПОРТИ С КРИЛА  
 (KO) 종단 정지대, 고정식, 옆 게이트용  
 (SRB) GRANIČNIK, UGRADNJA ZAVRTNJIMA, ZA KRILNA DVORIŠNA VRATA

Art.	1pc			CODE
	kg	pcs	kg	
LIMIT S	0,29	20	5,8	1700078

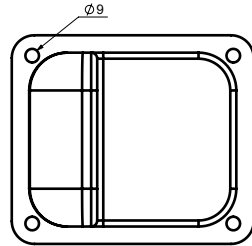
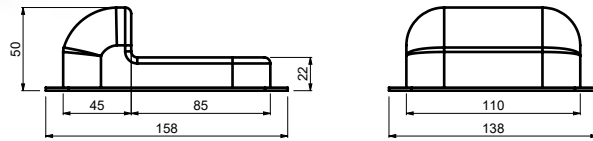

- (GB) END STOP, FIXED, FOR WING GATES
- (D) BODENANSCHLAG FÜR DREHTORE ZUM VERSCHRAUBEN
- (F) BUTÉE, FIXÉE, POUR PORTAILS À VANTAUX
- (E) TOPE FINAL, FIJO, PARA PUERTAS BATIENTES
- (P) BATEENTE, FIXO, PARA PORTÕES DE FOLHA
- (I) FERMO DI FINE CORSA, FISSA, PER CANCELLI A BATTENTE
- (DK) ENDESTOP, FAST, TIL FLØJPORTE
- (NL) EINDSTOP, VASTGESCHROEFD, VOOR DRAAIPOORTEN
- (N) ENDESTOPPER, FAST, FOR SVINGPORTER
- (S) ÄNDSTOPP, FAST, FÖR SLAGGRINDAR
- (FIN) PÄÄTYPYSÄYTIN, PYSYVÄ, ETEEN- JA TAAKSEPÄIN AVAUTUVIIN PORTTEIHIN
- (PL) OGRANICZNIK, PRZYKREĆANY, DO BRAM SKRZYDŁOWYCH
- (SK) DORAZ SPODNÝ PRE KRÍDLOVÚ BRÁNU, K PRISKRUTKOVANIU
- (EE) OTSALÕPP, FIKSEERITUD, TIIBVÄRAVATE JAOKS
- (LT) GALINIS RIBOKLIS, FIKSUOTAS, ATVERIAMIEMS VARTAMS
- (LV) GALA AIZTURIS, FIKSĒTS, VERAMAJIEM VĀRTIEM

- (CZ) DORAZ SPODNÍ PRO KRÍDLOVOU BRÁNU, K PŘÍŠROBOVÁNÍ
- (RO) OPRITOR CURSĂ, FIX, PENTRU UȘILE GLISANTE
- (HR) GRANIČNIK, UGRADNJA ZAVRTNJIMA, ZA KRILNA DVORIŠNA VRATA
- (RUS) НИЖНИЙ УПОР ДЛЯ РАСПАШНЫХ ВОРОТ, ПРИКРУЧИВАНИЕ ВИНТАМИ
- (SLO) ZAUSTAVLJALNIK, ZA PRIVITJE Z VIJAKI, ZA KRILNA VRATA
- (TR) UÇ TESPİT PARÇASI, SABİT, KANATLI BAHÇE KAPILARI İÇİN
- (AR) مناع طرفي، مثبت، للوابات الجانحية
- (CHN) 平开门固定式终点挡块
- (MAL) PENYENDAL HUJUNG, TETAP, UNTUK PINTU PAGAR AYUN
- (H) ÚTKÓZÓ, RÖGZÍTETT, SZÁRNYAS KAPUKHOZ
- (IL) מעצור תחתון צר לשער כנפיים התקנה בעינון
- (BG) СТОПЕР, ФИКСИРАН, ЗА ПОРТИ С КРИЛА
- (KO) 종단 정지대, 고정식, 윙 게이트용
- (SRB) GRANIČNIK, UGRADNJA ZAVRTNJIMA, ZA KRILNA DVORIŠNA VRATA

Art.	1pc		CODE
	kg	pcs	
LIMIT M	0,46	10	1700079

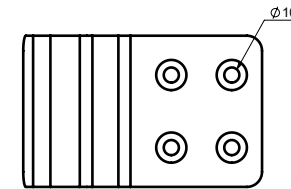
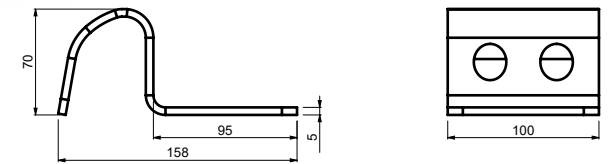

- (GB) END STOP, FIXED, FOR WING GATES
- (D) BODENANSCHLAG FÜR DREHTORE ZUM VERSCHRAUBEN
- (F) BUTÉE, FIXÉE, POUR PORTAILS À VANTAUX
- (E) TOPE FINAL, FIJO, PARA PUERTAS BATIENTES
- (P) BATEENTE, FIXO, PARA PORTÕES DE FOLHA
- (I) FERMO DI FINE CORSA, FISSA, PER CANCELLI A BATTENTE
- (DK) ENDESTOP, FAST, TIL FLØJPORTE
- (NL) EINDSTOP, VASTGESCHROEFD, VOOR DRAAIPOORTEN
- (N) ENDESTOPPER, FAST, FOR SVINGPORTER
- (S) ÄNDSTOPP, FAST, FÖR SLAGGRINDAR
- (FIN) PÄÄTYPYSÄYTIN, PYSYVÄ, ETEEN- JA TAAKSEPÄIN AVAUTUVIIN PORTTEIHIN
- (PL) OGRANICZNIK, PRZYKREĆANY, DO BRAM SKRZYDŁOWYCH
- (SK) DORAZ SPODNÝ PRE KRÍDLOVÚ BRÁNU, K PRISKRUTKOVANIU
- (EE) OTSALÕPP, FIKSEERITUD, TIIBVÄRAVATE JAOKS
- (LT) GALINIS RIBOKLIS, FIKSUOTAS, ATVERIAMIEMS VARTAMS
- (LV) GALA AIZTURIS, FIKSĒTS, VERAMAJIEM VĀRTIEM

- (CZ) DORAZ SPODNÍ PRO KRÍDLOVOU BRÁNU, K PŘÍŠROBOVÁNÍ
- (RO) OPRITOR CURSĂ, FIX, PENTRU UȘILE GLISANTE
- (HR) GRANIČNIK, UGRADNJA ZAVRTNJIMA, ZA KRILNA DVORIŠNA VRATA
- (RUS) НИЖНИЙ УПОР ДЛЯ РАСПАШНЫХ ВОРОТ, ПРИКРУЧИВАНИЕ ВИНТАМИ
- (SLO) ZAUSTAVLJALNIK, ZA PRIVITJE Z VIJAKI, ZA KRILNA VRATA
- (TR) UÇ TESPİT PARÇASI, SABİT, KANATLI BAHÇE KAPILARI İÇİN
- (AR) مناع طرفي، مثبت، للوابات الجانحية
- (CHN) 平开门固定式终点挡块
- (MAL) PENYENDAL HUJUNG, TETAP, UNTUK PINTU PAGAR AYUN
- (H) ÚTKÓZÓ, RÖGZÍTETT, SZÁRNYAS KAPUKHOZ
- (IL) מעצור תחתון צר לשער כנפיים התקנה בעינון
- (BG) СТОПЕР, ФИКСИРАН, ЗА ПОРТИ С КРИЛА
- (KO) 종단 정지대, 고정식, 윙 게이트용
- (SRB) GRANIČNIK, UGRADNJA ZAVRTNJIMA, ZA KRILNA DVORIŠNA VRATA

Art.	1pc		CODE
	kg	pcs	
LIMIT H	0,92	6	1700251



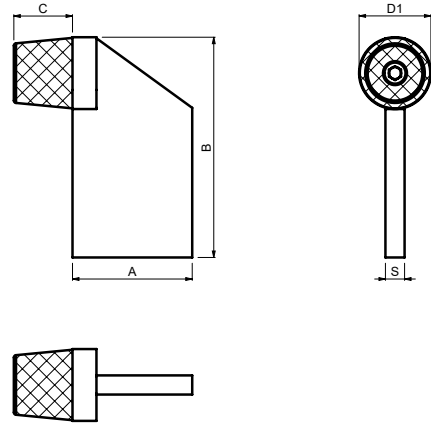

- (GB) END STOP, WELDED, FOR SLIDING AND WING GATES
- (D) GUMMIANSCHLAG FÜR SCHIEBE- UND DREHTORE ZUM ANSCHWEISSEN
- (F) BUTÉE, SOUDÉE, POUR PORTAILS COULISSANTS ET À VANTAUX
- (E) TOPE FINAL, SOLDADO, PARA PUERTAS BATIENTES Y CORREDERAS
- (P) BATEANTE, SOLDADO, PARA PORTÕES DESLIZANTES E DE FOLHA
- (I) FERMO DI FINE CORSA, SALDATO, PER CANCELLI SCORREVOLI E A BATTENTE
- (DK) ENDESTOP, STØBT, TIL SKYDE- OG FLØJPORTE
- (NL) EINDSTOP, GELAST, VOOR SCHUIF- EN DRAAIPOORTEN
- (N) ENDESTOPPER, SVEISET, FOR SKYVE- OG SVINGPORTER
- (S) ÄNDSTOPP, SVETSAT, FÖR SKJUTBARA GRINDAR OCH SLAGGRINDAR
- (FIN) PÄÄTYPYSÄYTIN, HITSATTU, ETEEN- JA TAAKSEPÄIN AVAUTUVIIN PORTEIHIIN
- (PL) ODBOJNIK, SPAWANY, DO BRAM PRZESUWNYCH I SKRZYDŁOWYCH
- (SK) DORAZ SPODNÝ PRE POSUVNÚ A KRÍDLOVÚ BRÁNU, K PRIVARENIU
- (EE) OTSALÕPP, KEEVITATUD, LIUG- JA TIIBVÄRAVATE JAOKS
- (LT) GALINIS RIBOKLIS, SUVIRINTAS, STUMDOMIESIEMS IR ATVERIAMIESIEMS VARTAMS
- (LV) GALA AIZTURIS, METINĀTS, BĪDĀMAJIEM UN VERĀMAJIEM VĀRTIEM

- (CZ) DORAZ SPODNÍ PRO POSUVNOU A KRÍDLOVOU BRÁNU, K PŘIVAŘENÍ
- (RO) OPRITOR CURSĂ, SUDAT, PENTRU UȘILE GLISANTE BATANTE
- (HR) GRANIČNIK, UGRADNJA ZAVARIVANJEM, ZA KLIZNA I KRILNA DVORIŠNA VRATA
- (RUS) ОГРАНИЧИТЕЛЬ ХОДА НИЖНИЙ ДЛЯ ОТКАТНЫХ И РАСПАШНЫХ ВОРОТ, ПРИВАРИВАНИЕ
- (SLO) ZAUSTAVLJALNIK, PRIVARJEN, ZA DRŠNA IN KRILNA VRATA
- (TR) UÇ TESPİT PARÇASI, KAYNAKLANMIŞ, SÜRGÜLÜ VE KANATLI BAHÇE KAPILARI İÇİN
- (AR) منع طرفي، ملتهب للوحدات المنزلقة والوحدات الحاذجة
- (CHN) 滑动门与平开门焊接式终点挡块
- (MAL) PENYENDAL HUJUNG, BERKIMPAL, UNTUK PINTU PAGAR GELONGSOR DAN AYUN
- (H) ÜTKÖZŐ, HEGESZTETT, TOLÓ- ÉS SZÁRNYAS KAPUKHOZ
- (IL) משגור גומי מתחום לשיער הדלת או כניסים, התקנה בדלת
- (BG) СТОПЕР, ЗАВАРЕН, ЗА ПЛЪЗГАЩИ ПОРТИ И ПОРТИ С КРИЛА
- (KO) 중단 장치대, 고정식, 슬라이딩 및 평 개이트용
- (SRB) GRANIČNIK, UGRADNJA ZAVARIVANJEM, ZA KLIZNA I KRILNA DVORIŠNA VRATA

Art.	D1	B	A	C	S	1pc	Image		CODE
							mm	kg	
ES 40	29	92	50	24,5	8	0,3	20	6	1700083
ES 50	39	110	70	39	10	0,62	10	6,2	1700084

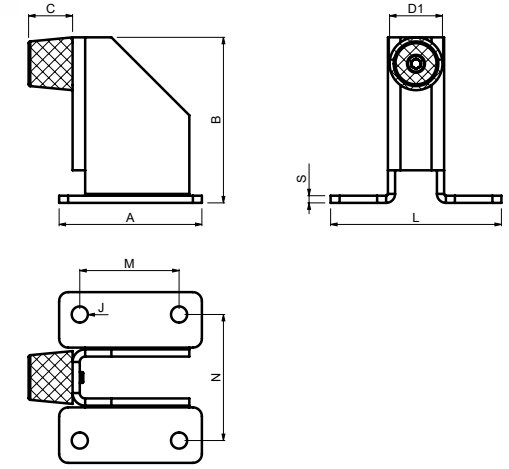

- (GB) END STOP, FIXED, FOR SLIDING AND WING GATES
- (D) GUMMIANSCHLAG FÜR SCHIEBE- UND DREHTORE ZUM VERSCHRAUBEN
- (F) BUTÉE, FIXÉE, POUR PORTAILS COULISSANTS ET À VANTAUX
- (E) TOPE FINAL, FIJO, PARA PUERTAS BATIENTES Y CORREDERAS
- (P) BATEANTE, FIXO, PARA PORTÕES DESLIZANTES E DE FOLHA
- (I) FERMO DI FINE CORSA, FISSO, PER CANCELLI SCORREVOLI E A BATTENTE
- (DK) ENDESTOP, FAST, TIL SKYDE- OG FLØJPORTE
- (NL) EINDSTOP, VASTGESCHROEFD, VOOR SCHUIF- EN DRAAIPOORTEN
- (N) ENDESTOPPER, FAST, FOR SKYVE- OG SVINGPORTER
- (S) ÄNDSTOPP, FAST, FÖR SKJUTBARA GRINDAR OCH SLAGGRINDAR
- (FIN) PÄÄTYPYSÄYTIN, PYSYVÄ, ETEEN- JA TAAKSEPÄIN AVAUTUVIIN PORTEIHIIN
- (PL) ODBOJNIK, PRZYKRĘCANY, DO BRAM PRZESUWNYCH I SKRZYDŁOWYCH
- (SK) DORAZ SPODNÝ PRE POSUVNÚ A KRÍDLOVÚ BRÁNU, K PRISKRUTKOVANIU
- (EE) OTSALÕPP, FIKSEERITUD, LIUG- JA TIIBVÄRAVATE JAOKS
- (LT) GALINIS RIBOKLIS, FIKSUOTAS, STUMDOMIESIEMS IR ATVERIAMIESIEMS VARTAMS
- (LV) GALA AIZTURIS, FIKSETS, BĪDĀMAJIEM UN VERĀMAJIEM VĀRTIEM

- (CZ) DORAZ SPODNÍ PRO POSUVNOU A KRÍDLOVOU BRÁNU, K PŘÍŠROUBOVÁNÍ
- (RO) OPRITOR CURSĂ, FIX, PENTRU UȘILE GLISANTE BATANTE
- (HR) GRANIČNIK, UGRADNJA ZAVRTNJIAMA, ZA KLIZNA I KRILNA DVORIŠNA VRATA
- (RUS) ОГРАНИЧИТЕЛЬ ХОДА НИЖНИЙ ДЛЯ ОТКАТНЫХ И РАСПАШНЫХ ВОРОТ, ПРИКРУЧИВАНИЕ ВИНТАМИ
- (SLO) ZAUSTAVLJALNIK, ZA PRIVITJE Z VJAKOM, ZA DRŠNA IN KRILNA VRATA
- (TR) UÇ TESPİT PARÇASI, SABİT, SÜRGÜLÜ VE KANATLI BAHÇE KAPILARI İÇİN
- (AR) منع طرفي، ملتهب للوحدات المنزلقة والوحدات الحاذجة
- (CHN) 滑动门与平开门固定式终点挡块
- (MAL) PENYENDAL HUJUNG, TETAP, UNTUK PINTU PAGAR GELONGSOR DAN AYUN
- (H) ÜTKÖZŐ, RÖGZÍTETT, TOLÓ- ÉS SZÁRNYAS KAPUKHOZ
- (IL) משגור גומי מתחום לשיער הדלת או כניסים, התקנה בדלת
- (BG) СТОПЕР, ФИКСИРАН, ЗА ПЛЪЗГАЩИ ПОРТИ И ПОРТИ С КРИЛА
- (KO) 중단 장치대, 고정식, 슬라이딩 및 평 개이트용
- (SRB) GRANIČNIK, UGRADNJA ZAVRTNJIAMA, ZA KLIZNA I KRILNA DVORIŠNA VRATA

Art.	D1	B	A	C	J	K	L	M	N	S	1pc	Image		CODE
												mm	kg	
ES 40 PN	29	92	80	24,5	9	68	96	55	70	4	0,5	10	5	1700089
ES 50 PN	39	110	95	39	11	84	114	65	84	4	0,75	5	3,75	1700090

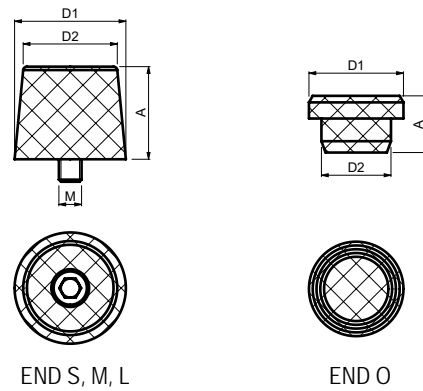

- (GB) RUBBER END STOP WITH SCREW
- (D) GUMMIANSCHLAG MIT SCHRAUBE
- (F) BUTÉE EN CAOUTCHOUC AVEC VIS
- (E) TOPE FINAL DE GOMA CON TUERCA
- (P) BATENTE DE BORRACHA COM PARAFUSO
- (I) FERMO DI FINE CORSA IN GOMMA CON VITE
- (DK) GUMMIENDESTOP MED SKRUE
- (NL) RUBBEREN EINDSTOP MET SCHROEF
- (N) GUMMI ENDESTOPPER MED SKRUE
- (S) ÄNDSTOPP AV GUMMI MED SKRUV
- (FIN) KUMINEN PÄÄTYPYSÄYTIN RUUVILLA
- (PL) ODBOJNIK GUMOWY ZE ŚRUBĄ
- (SK) DORAZ GUMOVÝ SO SKRUTKOU
- (EE) KUMMIST OTSALÕPP KRUVIGA
- (LT) GUMINIS RIBOKLIS SU SRAIGTU
- (LV) GUMIJAS GALA AIZTURIS AR SKRŪVI

- (CZ) DORAZ GUMOVÝ SE ŠROUBEM
- (RO) OPRITOR CURSĂ DE CAUCIUC CU FILET
- (HR) GUMENI GRANIČNIK S VIJKOM
- (RUS) ОГРАНИЧИТЕЛЬ ХОДА РЕЗИНОВЫЙ, С ВИНТОМ
- (SLO) GUMIJASTI ZAVSTAVLJALNIK Z VIJAKOM
- (TR) VIDALI LASTİK UÇ TESPİT PARÇASI
- (AR) معلق طرفي مطاطي مع الزرني
- (CHN) 螺钉家具橡胶终点挡块
- (MAL) PENYENDAL HUJUNG GETAH DENGAN SKRU
- (H) GUMI ŰTKÖZŐ CSAVARRAL
- (IL) מונע סוף עם בורג
- (BG) ГУМЕН СТОПЕР С БОЛТ
- (KO) 나사가 있는 고무 종단 장치대
- (SRB) GUMENI GRANIČNIK SA ZAVRTNJEM

Art.	D1	D2	A	M	1pc			CODE
						pcs	kg	
	Ø		mm		kg			
END S	29	22	12,5	M5	0,008	20	0,16	1700080
END M	29	24	24,5	M6	0,015	20	0,3	1700081
END L	39	34	39	M10	0,05	20	1	1700082
END O	25	18	15		0,002	20	0,04	1700349

“YOUR FUTURE IS  
CREATED BY WHAT  
YOU DO TODAY,  
NOT TOMORROW”

– Robert Kiyosaki –



"ALWAYS DELIVER  
MORE THAN  
EXPECTED"

– Larry Page



HIGH QUALITY GERMAN STEEL  
CAIS PARTNER

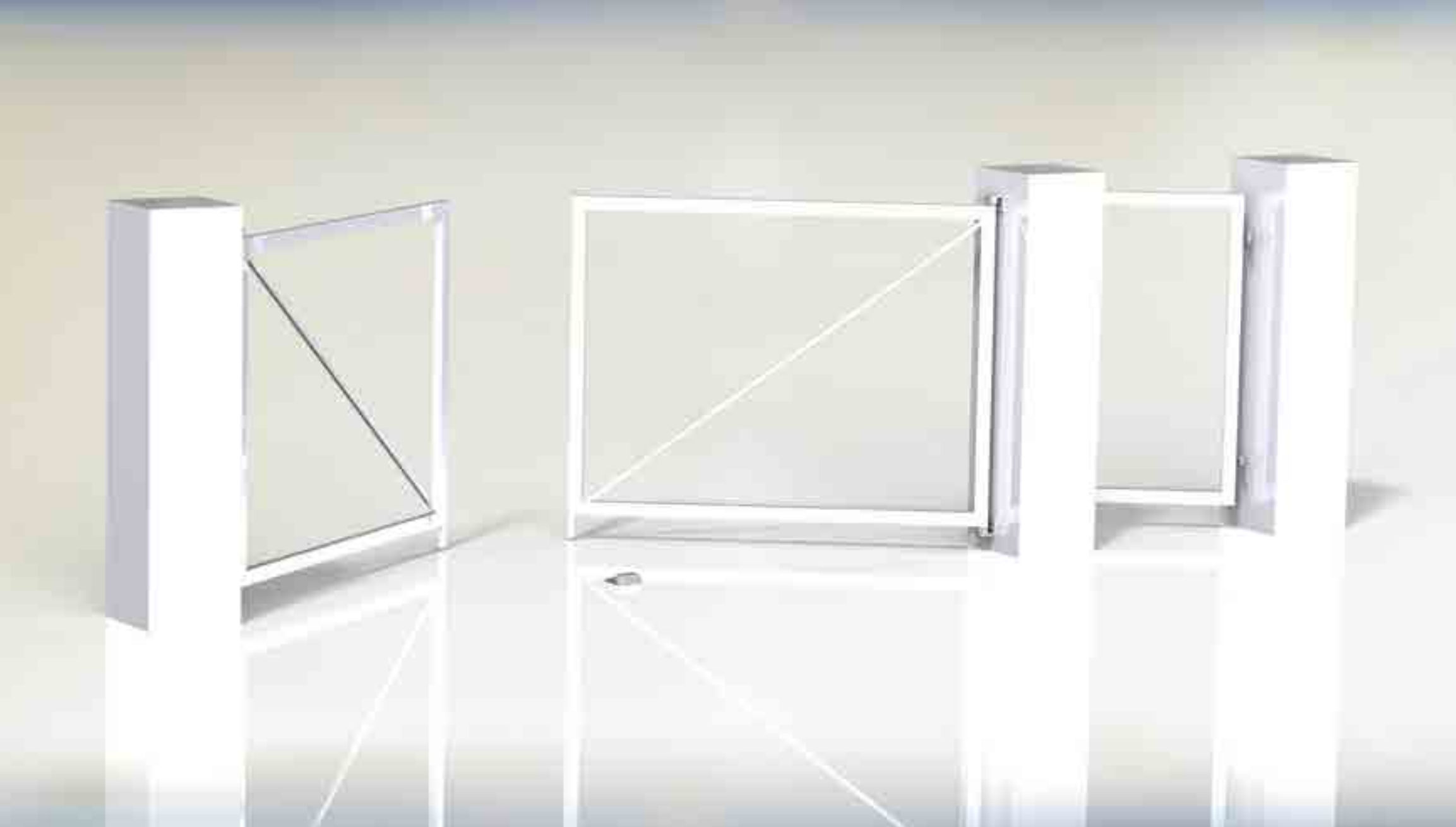

HARDWARE FOR SWING GATES

SWING GATES  CAIS

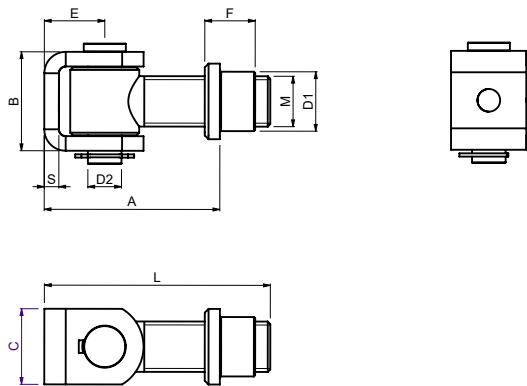
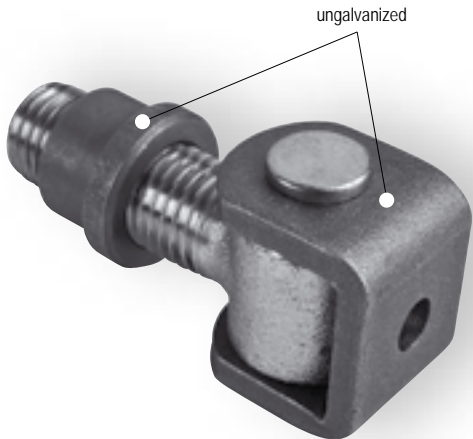

- (GB) ADJUSTABLE HINGE WITH NUT, WELDED, FOR STEEL COLUMN
- (D) TORBAND REGULIERBAR MIT MUTTER FÜR EISENSTEHER
- (F) GOND RÉGLABLE AVEC ÉCROU, SOUDÉ, POUR PILIER EN ACIER
- (E) BISAGRA AJUSTABLE CON PERNO, SOLDADA, PARA COLUMNA DE ACERO
- (P) DOBRADIÇA AJUSTÁVEL COM PORÇA, SOLDADA, PARA COLUNA DE AÇO
- (I) CERNIERA REGOLABILE CON DADO, SALDATA, PER MONTANTE IN ACCIAIO
- (DK) INDSTILLELIGT HÆNGSEL MED MØTRIK, STØBT, TIL STÅLSØJLE
- (NL) VERSTELBARE SCHARNIER MET MOER, GELAST, VOOR STALEN KOLOM
- (N) JUSTERBART HÆNGSEL MED MUTTER, SVEISET, FOR STÅLSØYLE
- (S) JUSTERBART GÅNGJÄRN MED MUTTER, SVEISET, FÖR STÅLSTOLPE
- (FIN) SÄÄDETTÄVÄ SARANA MUTTERILLA, HITSATTU, TERÄSPYLVÄÄSEEN
- (PL) ZAWIAS REGULOWANY Z NAKRĘTKĄ, SPAWANY, DO SŁUPKÓW STALOWYCH
- (SK) PÁNT REGULOVATEĽNÝ S MATICOU PRE KOVOVÉ STĽPY
- (EE) REGULEERITAV LIIGEND MUTRIGA, KEEVITATUD, TERASSAMBA JAOKS
- (LT) REGULIUOJAMAS LANKSTAS SU VERŽLE, SUVIRINTAS, PLIENINIAM STULPUI
- (LV) REGULĒJAMA VIRĀ AR UZGRIEZNI, METINĀTA, TĒRAUDA STABAM

- (CZ) PANT REGULOVATEĽNÝ S MATKOU PRO KOVOVÉ SLOUPY
- (RO) BALAMA REGLABILĂ CU PIULIȚĂ, SUDATĂ, PENTRU COLOANA DE OȚEL
- (HR) PRILAGODLJIVI ZGLOB S MATICOM, UGRADNJA ZAVARIVANJEM, ZA ČELIČNE STUPOVE
- (RUS) РЕГУЛИРУЮЩАЯСЯ ПЕТЛЯ С ГАЙКОЙ ДЛЯ МЕТАЛЛИЧЕСКИХ СТОЛБОВ
- (SLO) NASTAVLJIVI TEČAJ Z MATICO, PRIVARJEN, ZA JEKLENI STEBRICEK
- (TR) SOMUNLU AYARLANABİLİR MENTEŞE, KAYNAKLANMIŞ, ÇELİK SÜTUN İÇİN
- (AR) مفصل قابل للتعديل مع الصمولة ملحومة للعمود الفولاذي
- (CHN) 立柱焊接式带螺母可调铰链
- (MAL) ENGSEL BOLEH LARAS DENGAN NAT, BERKIMPAL, UNTUK TIANG KELULU
- (H) ÁLLÍTHATÓ ZSANÉR ANYÁVAL, HEGESZTETT, ACÉL OSZLOPHOZ
- (IL) מפרק עם מטרית מלוכה
- (BG) РЕГУЛИРУЕМА ПАНТА С ГАЙКА, ЗАВАРЕНА, ЗА СТОМАНЕНИ КОЛОНИ
- (KO) 너트가 있는 조절식 경첩, 용접식, 강철 기둥용
- (SRB) PODESIVA ŠARKA SA MATICOM, UGRADNJA ZAVARIVANJEM, ZA ČELIČNE STUBOVE

Art.	M	A min./max.	L	B	C	D1	D2	E	F	S	CAPACITY	1pc		CODE	
												kg	pcs		
		mm				∅		mm			1 pair/kg	kg	pcs	kg	
H 18	M18	47 - 73	84	39	30	23	14	25	18	6	90	0,36	20	7,2	1700093
H 20	M20	47 - 77	91	39	30	25	14	25	20	6	145	0,4	20	8	1700094
H 24	M24	55 - 87	106	48	36	30	16	30	25	6	220	0,67	10	6,7	1700095

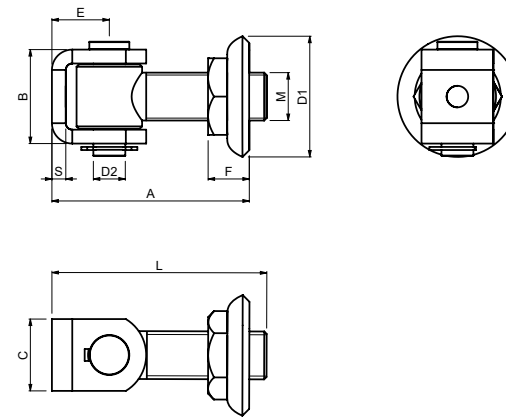
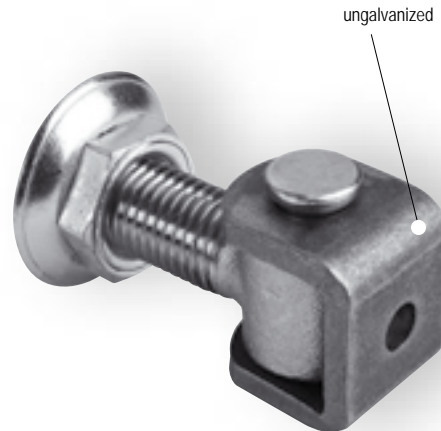

- (GB) ADJUSTABLE HINGE WITH NUT, WASHER, WELDED, FOR STEEL COLUMN
- (D) TORBAND REGULIERBAR MIT MUTTER FÜR EISENSTEHER
- (F) GOND RÉGLABLE AVEC ÉCROU ET RONDELLE, SOUDÉ, POUR PILIER EN ACIER
- (E) BISAGRA AJUSTABLE CON PERNO, ARANDELA, SOLDADA, PARA COLUMNA DE ACERO
- (P) DOBRADIÇA AJUSTÁVEL COM PORÇA, ARRUÉLA, SOLDADA, PARA COLUNA DE AÇO
- (I) CERNIERA REGOLABILE CON DADO, RONDELLA SALDATA, PER MONTANTE IN ACCIAIO
- (DK) INDSTILLELIGT HÆNGSEL MED MØTRIK, SPENDESKIVE, STØBT, TIL STÅLSØJLE
- (NL) VERSTELBARE SCHARNIER MET MOER, SLUITRING, GELAST, VOOR STALEN KOLOM
- (N) JUSTERBART HÆNGSEL MED MUTTER, SKIVE, SVEISET, FOR STÅLSØYLE
- (S) JUSTERBART GÅNGJÄRN MED MUTTER, BRICKA, SVEISET, FÖR STÅLSTOLPE
- (FIN) SÄÄDETTÄVÄ SARANA MUTTERILLA, ALUSLAATTA, HITSATTU, TERÄSPYLVÄÄSEEN
- (PL) ZAWIAS REGULOWANY Z NAKRĘTKĄ, PODKŁADKA, SPAWANY, DO SŁUPKÓW STALOWYCH
- (SK) PÁNT REGULOVATEĽNÝ S MATICOU A PODLOŽKOU PRE KOVOVÉ STĽPY
- (EE) REGULEERITAV LIIGEND MUTRIGA, SEIB, KEEVITATUD, TERASSAMBA JAOKS
- (LT) REGULIUOJAMAS LANKSTAS SU VERŽLE IR POVERŽLE, SUVIRINTAS, PLIENINIAM STULPUI
- (LV) REGULĒJAMA VIRĀ AR UZGRIEZNI UN PAPLĀKSNĪ, METINĀTA, TĒRAUDA STABAM

- (CZ) PANT REGULOVATEĽNÝ S MATKOU A PODLOŽKOU PRO KOVOVÉ SLOUPY
- (RO) BALAMA REGLABILĂ CU PIULIȚĂ, ȘABĂ, SUDATĂ, PENTRU COLOANA DE OȚEL
- (HR) PRILAGODLJIVI ZGLOB S MATICOM I PODLOŠKOM, UGRADNJA ZAVARIVANJEM, ZA ČELIČNE STUPOVE
- (RUS) РЕГУЛИРУЮЩАЯСЯ ПЕТЛЯ С ГАЙКОЙ И ШАЙБЫ ДЛЯ МЕТАЛЛИЧЕСКИХ СТОЛБОВ
- (SLO) NASTAVLJIVI TEČAJ Z MATICO, PODLOŽKO, PRIVARJEN, ZA JEKLENI STEBRICEK
- (TR) SOMUNLU AYARLANABİLİR MENTEŞE, CONTA, KAYNAKLANMIŞ, ÇELİK SÜTUN İÇİN
- (AR) مفصل قابل للتعديل مع الصمولة ملحومة مع طوق، للعمود الفولاذي
- (CHN) 立柱焊接式带螺母垫圈可调铰链
- (MAL) ENGSEL BOLEH LARAS DENGAN NAT, SESENDAL, BERKIMPAL, UNTUK TIANG KELULU
- (H) ÁLLÍTHATÓ ZSANÉR ANYÁVAL, ALÁTÉTTTEL, HEGESZTETT, ACÉL OSZLOPHOZ
- (IL) מפרק עם מטרית מלוכה
- (BG) РЕГУЛИРУЕМА ПАНТА С ГАЙКА, ШАЙБА, ЗА СТОМАНЕНИ КОЛОНИ
- (KO) 너트 및 와셔가 있는 조절식 경첩, 용접식, 강철 기둥용
- (SRB) PODESIVA ŠARKA BEZ MATICE, SA PODLOŠKOM, UGRADNJA ZAVARIVANJEM, ZA ČELIČNE STUBOVE

Art.	M	A min./max.	L	B	C	D1	D2	E	F	S	CAPACITY	1pc		CODE	
												kg	pcs		
		mm				∅		mm			1 pair/kg	kg	pcs	kg	
HN 18	M18	59 - 84	84	39	30	51	14	25	18	6	90	0,43	20	8,6	1700096
HN 20	M20	59 - 91	91	39	30	51	14	25	18	6	145	0,48	20	9,6	1700097
HN 24	M24	74 - 106	106	48	36	63	16	30	22	6	220	0,78	10	7,8	1700098

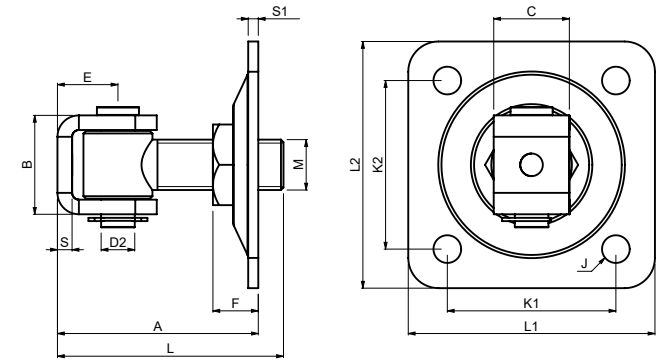
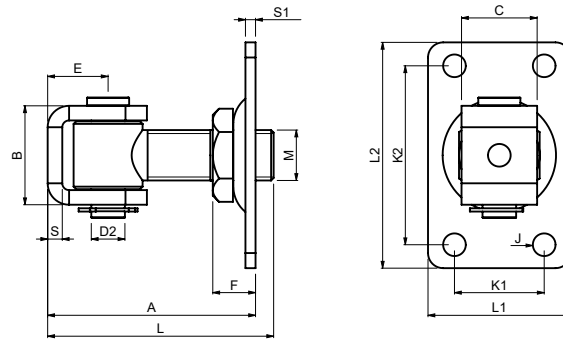
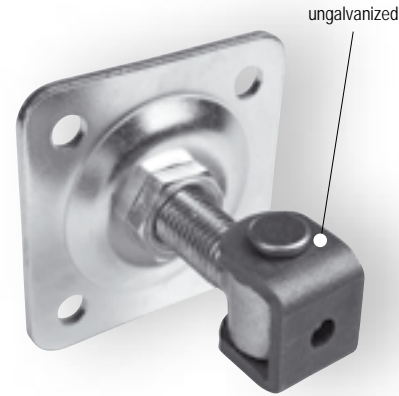
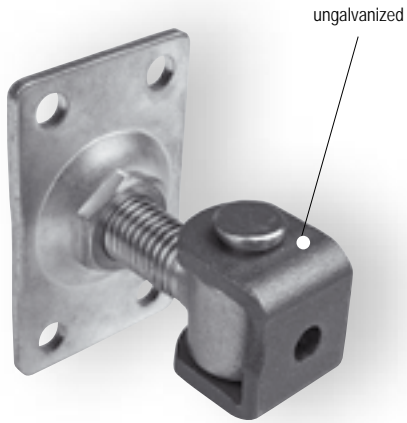

- (GB) ADJUSTABLE HINGE WITH PLATE, FIXED
- (D) TORBAND REGULIERBAR MIT PLATTE FÜR BETONSTEHER
- (F) GOND RÉGLABLE AVEC PLATINE, FIXE
- (E) BISAGRA AJUSTABLE CON PLATO, FIJA
- (P) DOBRADIČA AJUSTÁVEL COM PLACA, FIXA
- (I) CERNIERA REGOLABILE CON PIASTRA, FISSA
- (DK) INDSTILLELIGT HÆNGSEL MED PLADE, FAST
- (NL) VERSTELBARE SCHARNIER MET PLAAT, VASTGESCHROEFD
- (N) JUSTERBART HENGSEL MED PLATE, FAST
- (S) JUSTERBART GÅNGJÄRN MED PLATTA, FAST
- (FIN) SÄÄDETTÄVÄ SARANA LEVYLÄ, PYSYVÄ
- (PL) ZAWIAS REGULOWANY Z PŁYTKĄ, PRZYKRĘCANY
- (SK) PÁNT REGULOVATELNÝ S PĽATNOU PRE MUROVANÉ A KOVOVÉ STĽPY
- (EE) REGULĒERITAV LIĒGEND PLAADIGA, FIKSEERITUD
- (LT) REGULIUOJAMAS LANKŠTAS SU PLOKŠTELE, FIKSUOTAS
- (LV) REGULĒJAMA VIRĀR PLĀKSNĪ, FIKSĒTA

- (CZ) PÁNT REGULOVATELNÝ S PĽATNOU PRO ZDĚNÉ A KOVOVÉ SLOUPY
- (RO) BALAMA REGLABILĂ CU PLACĂ, FIXĂ
- (HR) PRILAGODLJIVI ZGLOB S PLOČOM, UGRADNJA ZAVRTNJIMA
- (RUS) РЕГУЛИРУЮЩАЯСЯ ПЕТЛЯ С ПЛАСТИНОЙ ДЛЯ БЕТОННЫХ И МЕТАЛЛИЧЕСКИХ СТОЛБОВ
- (SLO) NASTAVLJIVI TEČAJ S PLOŠČO, FIKSNI
- (TR) PLAKALI AYARLANABİLİR MENTEŞE, SABİT
- (AR) مفصل قابل التعديل مع الوحة ثابت
- (CHN) 帶軟鏈板的固定式可調軟鏈
- (MAL) ENGSEL BOLEH LARAS DENGAN PLAT, TETAP
- (H) ÁLLÍTHATÓ ZSANÉR LEMEZZEL, RÖGZÍTETT
- (IL) ציר מתכוון עם פלטה, התקנה ביעוט
- (BG) РЕГУЛИРУЕМА ПАНТА С ПЛАНКА, ФИКСИРАНА
- (KO) 조절식 경첩 및 플레이트, 고정식
- (SRB) PODESIVA ŠARKA SA PLOČOM, UGRADNJA ZAVRTNJIMA

- (GB) ADJUSTABLE HINGE WITH PLATE, FIXED
- (D) TORBAND REGULIERBAR MIT PLATTE FÜR BETONSTEHER
- (F) GOND RÉGLABLE AVEC PLATINE, FIXE
- (E) BISAGRA AJUSTABLE CON PLATO, FIJA
- (P) DOBRADIČA AJUSTÁVEL COM PLACA, FIXA
- (I) CERNIERA REGOLABILE CON PIASTRA, FISSA
- (DK) INDSTILLELIGT HÆNGSEL MED PLADE, FAST
- (NL) VERSTELBARE SCHARNIER MET PLAAT, VASTGESCHROEFD
- (N) JUSTERBART HENGSEL MED PLATE, FAST
- (S) JUSTERBART GÅNGJÄRN MED PLATTA, FAST
- (FIN) SÄÄDETTÄVÄ SARANA LEVYLÄ, PYSYVÄ
- (PL) ZAWIAS REGULOWANY Z PŁYTKĄ, PRZYKRĘCANY
- (SK) PÁNT REGULOVATELNÝ S PĽATNOU PRE MUROVANÉ A KOVOVÉ STĽPY
- (EE) REGULĒERITAV LIĒGEND PLAADIGA, FIKSEERITUD
- (LT) REGULIUOJAMAS LANKŠTAS SU PLOKŠTELE, FIKSUOTAS
- (LV) REGULĒJAMA VIRĀR PLĀKSNĪ, FIKSĒTA

- (CZ) PÁNT REGULOVATELNÝ S PĽATNOU PRO ZDĚNÉ A KOVOVÉ SLOUPY
- (RO) BALAMA REGLABILĂ CU PLACĂ, FIXĂ
- (HR) PRILAGODLJIVI ZGLOB S PLOČOM, UGRADNJA ZAVRTNJIMA
- (RUS) РЕГУЛИРУЮЩАЯСЯ ПЕТЛЯ С ПЛАСТИНОЙ ДЛЯ БЕТОННЫХ И МЕТАЛЛИЧЕСКИХ СТОЛБОВ
- (SLO) NASTAVLJIVI TEČAJ S PLOŠČO, FIKSNI
- (TR) PLAKALI AYARLANABİLİR MENTEŞE, SABİT
- (AR) مفصل قابل التعديل مع الوحة ثابت
- (CHN) 帶軟鏈板的固定式可調軟鏈
- (MAL) ENGSEL BOLEH LARAS DENGAN PLAT, TETAP
- (H) ÁLLÍTHATÓ ZSANÉR LEMEZZEL, RÖGZÍTETT
- (IL) ציר מתכוון עם פלטה, התקנה ביעוט
- (BG) РЕГУЛИРУЕМА ПАНТА С ПЛАНКА, ФИКСИРАНА
- (KO) 조절식 경첩 및 플레이트, 고정식
- (SRB) PODESIVA ŠARKA SA PLOČOM, UGRADNJA ZAVRTNJIMA

Art.	M	L1	L2	A min./max.	L	B	C	D2	E	F	J	K1	K2	S	S1	CAPACITY	1pc		CODE	
				mm			mm	mm	mm	mm	mm	mm	mm	mm	mm	1 pair/kg	kg	pcs	kg	
HP 18 R	M18	56	90	56 - 84	84	39	30	14	25	14	9	35	70	6	4	90	0,49	20	9,8	1700099

Art.	M	L1	L2	A min./max.	L	B	C	D2	E	F	J	K1	K2	S	S1	CAPACITY	1pc		CODE	
				mm			mm	mm	mm	mm	mm	mm	mm	mm	mm	1 pair/kg	kg	pcs	kg	
HP 20 S	M20	98	98	59 - 91	91	39	30	14	25	18	11	67	67	6	4	145	0,69	10	6,9	1700101
HP 24 S	M24	120	120	74 - 106	106	48	36	16	30	22	11	90	90	6	5	220	1,21	10	12,1	1700102

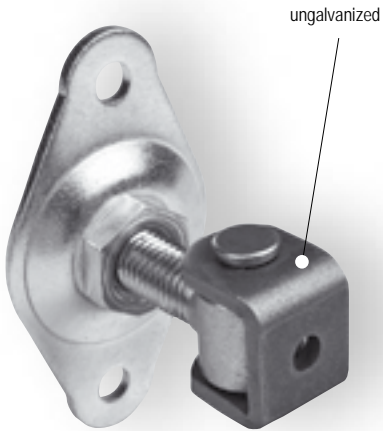

ungalvanized

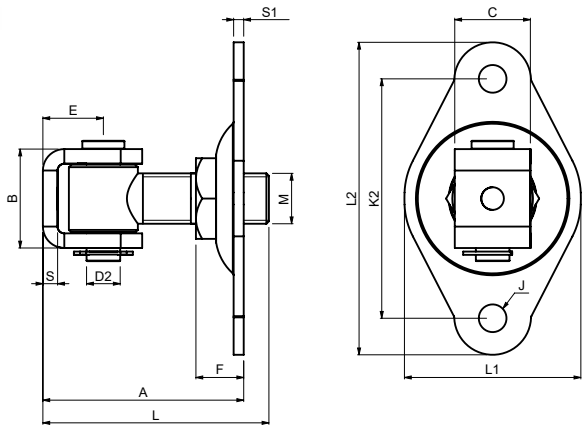

- (GB) ADJUSTABLE HINGE WITH PLATE, FIXED
- (D) TORBAND REGULIERBAR MIT PLATTE FÜR BETONSTEHER
- (F) GOND RÉGLABLE AVEC PLATINE, FIXÉ
- (E) BISAGRA AJUSTABLE CON PLATO, FIJA
- (P) DOBRADIČA AJUSTÁVEL COM PLACA, FIXA
- (I) CERNIERA REGOLABILE CON PIASTRA, FISSA
- (DK) INDSTILLELIGT HÆNGSEL MED PLADE, FAST
- (NL) VERSTELBARE SCHARNIER MET PLAAT, VASTGESCHROEFD
- (N) JUSTERBART HÆNGSEL MED PLATE, FAST
- (S) JUSTERBART GÅNGJÄRN MED PLATTA, FAST
- (FIN) SÄÄDETTÄVÄ SARANA LEVYLLÄ, PYSYVÄ
- (PL) ZAWIAS REGULOWANY Z PŁYTKĄ, PRZYKREŚCANY
- (SK) PÁNT REGULOVATEĽNÝ S PĽATŇOU PRE MUROVANÉ A KOVOVÉ STĽPY
- (EE) REGULEERITAV LIIGEND PLAADIGA, FIKSEERITUD
- (LT) REGULIUOJAMAS LANKSTAS SU PLOKŠTELE, FIKSUOTAS
- (LV) REGULĒJAMA VIRĀ AR PLĀKSNĪ, FIKSĒTA

- (CZ) PÁNT REGULOVATEĽNÝ S PĽATŇOU PRO ZDĚNÉ A KOVOVÉ SLOUPY
- (RO) BALAMA REGLABILĂ CU PLACĂ, FIXĂ
- (HR) PRILAGODLJIVI ZGLOB S PLOČOM, UGRADNJA ZAVRTNJIMA
- (RUS) РЕГУЛИРУЮЩАЯСЯ ПЕТЛЯ С ПЛАСТИНОЙ ДЛЯ БЕТОННЫХ И МЕТАЛЛИЧЕСКИХ СТОЛБОВ
- (SLO) NASTAVLJIVI TEČAJ S PLOŠČO, FIKSNI
- (TR) PLAKALI AYARLANABİLİR MENTEŞE, SABİT
- (AR) مفصل قابل التعديل مع اللوحة ثابت
- (CHN) 帶較鏈板的固定式可調較鏈
- (MAL) ENGSEL BOLEH LARAS DENGAN PLAT, TETAP
- (H) ÁLLÍTHATÓ ZSANÉR LEMEZZEL, RÖGZÍTETT
- (IL) ציר מתכוון עם שריון לתיקת בטון
- (BG) РЕГУЛИРУЕМА ПАНТА С ПЛАТКА, ФИКСИРАНА
- (KO) 조절식 경첩 및 플레이트, 고정식
- (SRB) PODESIVA ŠARKA SA PLOČOM, UGRADNJA ZAVRTNJIMA

Art.	M	L1	L2	A min./max.		L	B	C	D2	E	F	J	K2	S	S1	CAPACITY	1pc	1pc		CODE
				mm	mm													kg	pcs	
HP 18 O	M18	69	124	59 - 84	84	39	30	14	25	18	11	95	6	4	90	0,55	20	11	1700100	
HP 20 SO	M20	69	124	59 - 91	91	39	30	14	25	18	11	95	6	4	145	0,58	10	5,8	1700223	

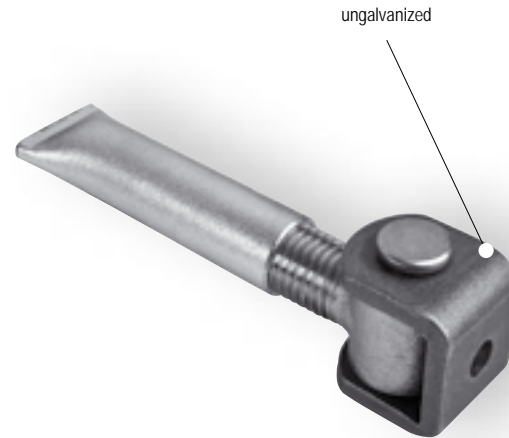

ungalvanized

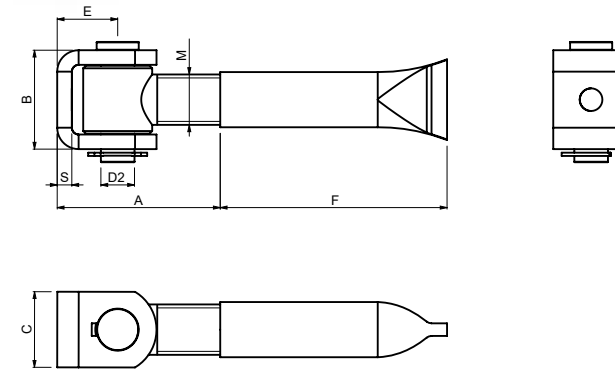
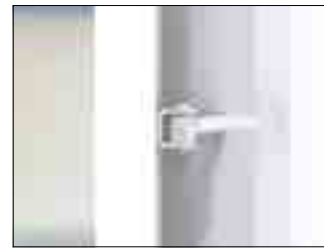

- (GB) ADJUSTABLE HINGE FOR MASONARY
- (D) TORBAND REGULIERBAR MIT GEWINDEHÜLSE
- (F) GOND RÉGLABLE POUR MAÇONNERIE
- (E) BISAGRA AJUSTABLE PARA ALBAÑILERÍA
- (P) DOBRADIČA AJUSTÁVEL PARA ALVENARIA
- (I) CERNIERA REGOLABILE PER MURATURA
- (DK) INDSTILLELIGT HÆNGSEL TIL MURVÆRK
- (NL) VERSTELBARE SCHARNIER VOOR METSELWERK
- (N) JUSTERBART HÆNGSEL FOR MURVERK
- (S) JUSTERBART GÅNGJÄRN FÖR MURNING
- (FIN) SÄÄDETTÄVÄ SARANA MUURAUKSEEN
- (PL) ZAWIAS REGULOWANY DO WMUROWANIA
- (SK) PÁNT REGULOVATEĽNÝ SO ZÁVITOVOU VLOŽKOU PRE MUROVANÉ STĽPY
- (EE) REGULEERITAV LIIGEND MÜÜRITISE JAOKS
- (LT) REGULIUOJAMAS LANKSTAS MŪRIUI
- (LV) REGULĒJAMA VIRĀ MŪRĒJUMIEM

- (CZ) PÁNT REGULOVATEĽNÝ SE ZÁVITOVOU VLOŽKOU PRO ZDĚNÉ SLOUPY
- (RO) BALAMA REGLABILĂ PENTRU ZIDĂRIE
- (HR) PRILAGODLJIVI ZGLOB S KLINOM ZA ZID
- (RUS) РЕГУЛИРУЮЩАЯСЯ ПЕТЛЯ С ВКЛАДЫШЕМ С РЕЗЬБОЙ ДЛЯ БЕТОННЫХ СТОЛБОВ
- (SLO) NASTAVLJIVI TEČAJ, ZIDNI
- (TR) KAGIR YAPILAR İÇİN AYARLANABİLİR MENTEŞE
- (AR) مفصل قابل للتثبيت خاص بالبناء
- (CHN) 砌体可調較鏈
- (MAL) ENGSEL BOLEH LARAS UNTUK BATU-BATA
- (H) ÁLLÍTHATÓ ZSANÉR TÉGLAFALBA
- (IL) ציר מתכוון עם שריון לתיקת בטון
- (BG) РЕГУЛИРУЕМА ПАНТА С ВТУЛКА С РЕЗБА
- (KO) 석조물 조절식 경첩
- (SRB) PODESIVA ŠARKA SA KLINOM ZA ZID

Art.	M	A min./max.		B	C	D2	E	F	S	CAPACITY	1pc	1pc		CODE
		mm	mm									kg	pcs	
HW 18	M18	43 - 70	39	30	14	25	75	6	90	0,42	20	8,4	1700103	
HW 20	M20	43 - 74	39	30	14	25	90	6	145	0,44	20	8,8	1700104	
HW 24	M24	52 - 84	48	36	16	30	100	6	220	0,74	10	7,4	1700105	

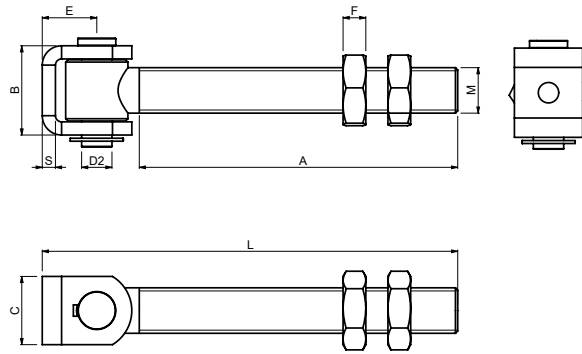
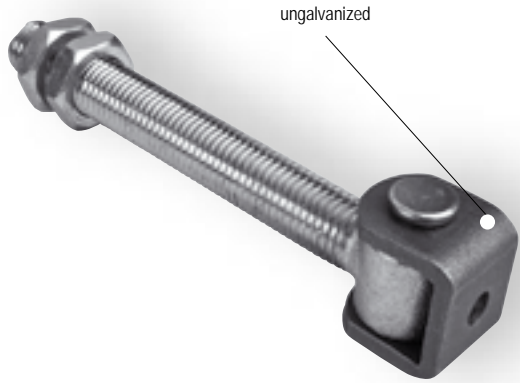

- (GB) ADJUSTABLE HINGE WITH LONGER BAR, FOR WOOD OR STEEL COLUMN
- (D) TORBAND MIT GEWINDESTANGE FÜR HOLZ- UND EISENSTEHER
- (F) GOND RÉGLABLE AVEC BARRE LONGUE, POUR BOIS OU PILIER EN ACIER
- (E) BISAGRA AJUSTABLE CON BARRA MAYOR, PARA COLUMNA DE ACERO O DE MADERA
- (P) DOBRADIÇA AJUSTÁVEL COM BARRA MAIS LONGA, PARA COLUNA DE MADEIRA OU AÇO
- (I) CERNIERA REGOLABILE CON BARRA ALLUNGATA, PER MONTANTE IN LEGNO O ACCIAIO
- (DK) INDSTILLELIGT HÆNGSEL MED LÆNGERE STANG, TIL TRÆ- ELLER STÅLSØJLE
- (NL) VERSTELBARE SCHARNIER MET LANGERE STEEL, VOOR HOUTEN OF STALEN KOLOMMEN
- (N) JUSTERBART HÆNGSEL MED LENGRE STANG, TIL TRE- ELLER STÅLSØYLE
- (S) JUSTERBART GÅNGJÄRN MED FÖRLÄNGD STÅNG, FÖR TRÄ- ELLER STÅLSTOLPE
- (FIN) SÄÄDETTÄVÄ SARANA PITKÄLLÄ TANGOLLA, PUU-TAI TERÄSPYLVÄSEEN
- (PL) ZAWIAS REGULOWANY Z DŁUŻSZYM PRĘTEM DO SŁUPKÓW DREWNIANYCH LUB STALOWYCH
- (SK) PÁNT REGULOVATEĽNÝ SO ZÁVITOVOU TYČOU PRE DREVENÉ A KOVOVÉ STĽPY
- (EE) REGULĒERITAV LIIGEND PIKEMA TALAGA, PUIT- VÕI TERASSAMBA JAOKS
- (LT) REGULIUOJAMAS LANKSTAS SU ILGESNIU STRYPŲ, MEDINIAM ARBA PLIENIAM STULPŲ
- (LV) REGULĒJAMA VIRAR GARĀKU STIENI KOKA VAI TĒRAUDA STABAM

- (CZ) PÁNT REGULOVATEĽNÝ SE ZÁVITOVOU TYČÍ PRO DŘEVĚNÉ A KOVOVÉ SLOUPY
- (RO) BALAMA REGLABILĂ CU BARĂ LUNGĂ, PENTRU COLOANĂ DE OȚEL SAU LEMN
- (HR) PRILAGODLJIVI ZGLOB S DULJIM NAVOJEM, ZA DRVENE ILI ČELIČNE STUPOVE
- (RUS) РЕГУЛИРУЮЩАЯСЯ ПЕТЛЯ СО СТЕРЖНЕМ С РЕЗЬБОЙ ДЛЯ ДЕРЕВЯННЫХ И МЕТАЛЛИЧЕСКИХ СТОЛБОВ
- (SLO) NASTAVLJIVI TEČAJ Z NAVOJNO SPONO, ZA LESENI ALI JEKLENI STEBRICEK
- (TR) UZUN ÇUBUKLU AYARLANABİLİR MENTEŞE, TAHTA VEYA ÇELİK SÜTUN İÇİN
- (AR) مفصل قابل للتعديل مع البرج، لأكبر طول الأعمدة الخشبية أو الفولاذية
- (CHN) 木柱或钢柱带长杆的可调铰链
- (MAL) ENGSEL BOLEH LARAS DENGAN BAR PANJANG, UNTUK TIANG KAYU ATAU KELUJI
- (H) ÁLLÍTHATÓ ZSANÉR HOSSZÚ SZÁRRAL, FA ÉS ACÉL OSZLOPHOZ
- (IL) ציר מתכוון עם פלטה לזנב או לטבעת
- (BG) МНОГО ДЪЛГА РЕГУЛИРУЕМА ПАНТА, ЗА ДЪРВЕНИ И СТОМАНЕНИ КОЛОНИ
- (KO) 장대가 있는 조절식 경첩, 목재 또는 강철 기둥용
- (SRB) PODESIVA ŠARKA SA DUŽIM NAVOJEM, ZA DRVENE ILI ČELIČNE STUBOVE

Art.	M	A	L	B	C	D2	E	F	S	CAPACITY	1pc		CODE	
											1 pair/kg	kg		pcs
HL 20	M20	143	185	39	30	14	25	10	6	145	0,62	10	6,2	1700106
HL 24	M24	155	208	48	36	16	30	12	6	220	1,01	10	10,1	1700107

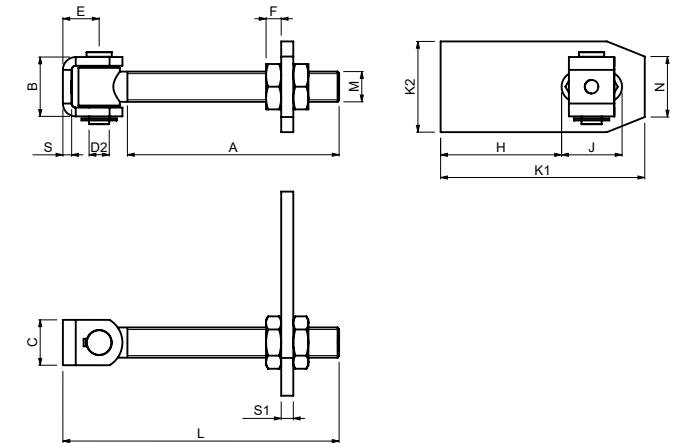

- (GB) ADJUSTABLE HINGE WITH PLATE, FIXED
- (D) TORBAND REGULIERBAR MIT PLATTE FÜR EISENSTEHER
- (F) GOND RÉGLABLE AVEC PLATINE, FIXÉ
- (E) BISAGRA AJUSTABLE CON PLATO, FIJA
- (P) DOBRADIÇA AJUSTÁVEL COM PLACA, FIXA
- (I) CERNIERA REGOLABILE CON PIASTRA, FISSA
- (DK) INDSTILLELIGT HÆNGSEL MED PLADE, FAST
- (NL) VERSTELBARE SCHARNIER MET PLAAT, VASTGESCHROEFD
- (N) JUSTERBART HÆNGSEL MED PLATE, FAST
- (S) JUSTERBART GÅNGJÄRN MED PLATTA, FAST
- (FIN) SÄÄDETTÄVÄ SARANA LEVYLLÄ, PYSYVÄ
- (PL) ZAWIAS REGULOWANY Z PŁYTKĄ, PRZYKRĘCANY
- (SK) PÁNT REGULOVATEĽNÝ S PĽATŇOU PRE MUROVANÉ A KOVOVÉ STĽPY
- (EE) REGULĒERITAV LIIGEND PLAADIGA, FIKSEERITUD
- (LT) REGULIUOJAMAS LANKSTAS SU PLOKŠTELE, FIKSUOTAS
- (LV) REGULĒJAMA VIRAR AR PĻĀKŠNI, FIKSĒTA

- (CZ) PÁNT REGULOVATEĽNÝ S PĽOTNOU PRO KOVOVÉ SLOUPY
- (RO) BALAMA REGLABILĂ CU PLACĂ, FIXĂ
- (HR) PRILAGODLJIVI ZGLOB S PLOČOM, UGRADNJA ZAVRTNJIMA
- (RUS) РЕГУЛИРУЮЩАЯСЯ ПЕТЛЯ С ПЛАСТИНОЙ ДЛЯ БЕТОННЫХ И МЕТАЛЛИЧЕСКИХ СТОЛБОВ
- (SLO) NASTAVLJIVI TEČAJ S PLOŠČO, FIKSNI
- (TR) PLAKALI AYARLANABİLİR MENTEŞE, SABİT
- (AR) مفصل قابل للتعديل مع اللوحة، ثابت
- (CHN) 帶軟鐵板的固定式可調铰链
- (MAL) ENGSEL BOLEH LARAS DENGAN PLAT, TETAP
- (H) ÁLLÍTHATÓ ZSANÉR LEMEZZEL, RÖGZÍTETT
- (IL) ציר מתכוון עם פלטה לעמוד בטון או מתכת
- (BG) РЕГУЛИРУЕМА ПАНТА С ПЛАНКА, ФИКСИРАНА
- (KO) 조절식 경첩 및 플레이트, 고정식
- (SRB) PODESIVA ŠARKA SA PLOČOM, UGRADNJA ZAVRTNJIMA

Art.	M	A	L	B	C	D2	E	F	S	S1	K1	K2	H	J	N	CAPACITY	1pc		CODE	
																	1 pair/kg	kg		pcs
HL 20 G	M20	143	185	39	30	14	25	10	6	8	135	60	80	40	40	145	1,06	10	10,6	1700187
HL 24 G	M24	155	208	48	36	16	30	12	6	12	150	70	73	44	45	220	1,87	4	7,48	1700188

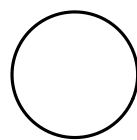

- (GB) LOWER HINGE WITH BEARING
- (D) DRUCKLAGER FÜR DREHTORE
- (F) GOND INFÉRIEUR AVEC ROULEMENT
- (E) BISAGRA INFERIOR CON RODAMIENTO
- (P) DOBRADIČA INFERIOR COM ROLAMENTO
- (I) CERNIERA INFERIORE CON CUSCINETTO
- (DK) NEDERSTE HÆNGSEL MED LEJE
- (NL) ONDERSTE SCHANIERPLAAT MET DRUKLAGER
- (N) NEDRE HENGSEL MED LAGER
- (S) UNDRE GÅNGJÄRN MED LAGER
- (FIN) ALASARANA LAAKERILLA
- (PL) ZAWIAS DOLNY Z ŁOŻYSKIEM
- (SK) PÁNT SPODNÝ LOŽISKOVÝ
- (EE) ALUMINE LIIGEND LAAGRIGA
- (LT) APATINIS LANKSTAS SU GUOLIU
- (LV) APAKŠĒJĀ VIRĀ AR GULTNI

- (CZ) PANT SPODNÍ LOŽISKOVÝ
- (RO) BALAMA INFERIOARĂ CU LAGĂR
- (HR) DONJI ZGLOB S LEŽAJEVIMA
- (RUS) ПЕТЛЯ-ШАРНИР НИЖНЯЯ, ПОДШИПНИКОВАЯ
- (SLO) SPODNJI TEČAJ Z LEŽAJEM
- (TR) RULMANLI ALT MENTEŞE
- (AR) مفصل منخفض مع المحمل
- (CHN) 帶軸承的下鞍鏈
- (MAL) ENGSEL BAWAH DENGAN BEARING
- (H) ALSÓ ZSANÉR CSAFÁGGYAL
- (IL) ציר מיסב עליון
- (BG) ДОЛНА ПАНТА С ЛАГЕР ЗА ПОРТИ С КРИЛА
- (KO) 베어링이 있는 하단 경첩
- (SRB) DONJA ŠARKA SA LEŽAJEM

Art.	D1	C	CAPACITY	1pc		CODE	
				kg	kg	pcs	kg
AB 50 L	50	33	600	0,43	10	4,3	1700110
AB 70 L	68	41	1000	0,98	10	9,8	1700111

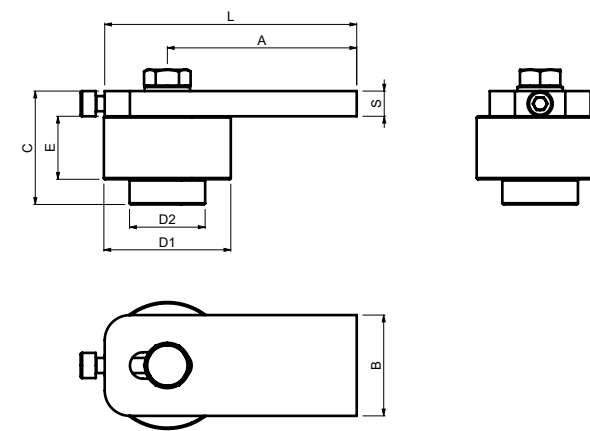

- (GB) UPPER HINGE WITH BEARING
- (D) OBERES DREHLAGER FÜR DREHTORE
- (F) GOND SUPÉRIEUR AVEC ROULEMENT
- (E) BISAGRA SUPERIOR CON RODAMIENTO
- (P) DOBRADIČA SUPERIOR COM ROLAMENTO
- (I) CERNIERA SUPERIORE CON CUSCINETTO
- (DK) ØVERSTE HÆNGSEL MED LEJE
- (NL) BOVENSTE SCHANIERPLAAT MET DRUKLAGER
- (N) TOPPHENGSEL MED LAGER
- (S) ÖVRE GÅNGJÄRN MED LAGER
- (FIN) YLÄSARANA LAAKERILLA
- (PL) ZAWIAS GÓRNY Z ŁOŻYSKIEM
- (SK) PÁNT HORNÝ LOŽISKOVÝ
- (EE) ÜLEMINE LIIGEND LAAGRIGA
- (LT) VIRŠUTINIS LANKSTAS SU GUOLIU
- (LV) AUGŠĒJĀ VIRĀ AR GULTNI

- (CZ) PANT HORNÍ LOŽISKOVÝ
- (RO) BALAMA SUPERIOARĂ CU LAGĂR
- (HR) GORNJI ZGLOB S LEŽAJEVIMA
- (RUS) ПЕТЛЯ-ШАРНИР ВЕРХНЯЯ, ПОДШИПНИКОВАЯ
- (SLO) ZGORNJI TEČAJ Z LEŽAJEM
- (TR) RULMANLI ÜST MENTEŞE
- (AR) مفصل عالي مع المحمل
- (CHN) 帶軸承的上鞍鏈
- (MAL) ENGSEL ATAS DENGAN BEARING
- (H) FELSŐ ZSANÉR CSAFÁGGYAL
- (IL) ציר מיסב עליון
- (BG) ГОРНА ПАНТА С ЛАГЕР ЗА ПОРТИ С КРИЛА
- (KO) 베어링이 있는 상단 경첩
- (SRB) GORNJA ŠARKA SA LEŽAJEM

Art.	D1	D2	A min./max.	B	C	E	L	S	CAPACITY	1pc		CODE	
										kg	kg	pcs	kg
AB 50 A	50	30	75 - 85	40	42	21	100	10	420	0,66	10	6,6	1700112
AB 70 A	68	38	92 - 110	60	55	31	130	12	780	1,6	10	16	1700113

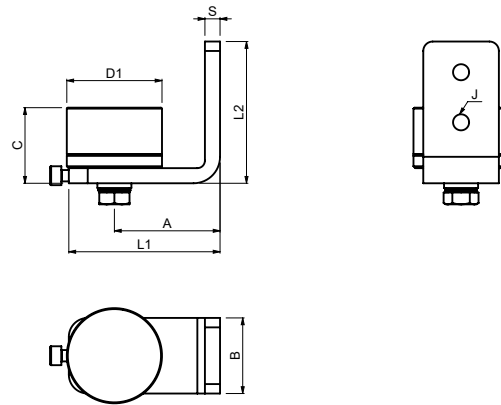

- (GB) LOWER HINGE WITH BEARINGS, SUPPORT
- (D) UNTERES SCHARNIER MIT LAGERN, STÜTZE
- (F) CHARNIÈRE INFÉRIEURE AVEC ROULEMENTS, SUPPORT
- (E) ARTICULACIÓN INFERIOR CON RODAMIENTOS, SOPORTE
- (P) DOBRADIČA INFERIOR COM ROLAMENTOS, SUPORTE
- (I) CERNIERA INFERIORE CON CUSCINETTI, SOSTEGNO
- (DK) NEDERSTE HÆNGSEL MED LEJER, STØTTE
- (NL) ONDERSTE STEUNPUNT MET LAGERS, STEUN
- (N) NEDRE HÆNGSLE MED LAGER, STØTTE
- (S) NEDRE GÅNGJÄRN MED LAGER, STÖD
- (FIN) ALASARANA LAAKEREILLA, TUKI
- (PL) ZAWIAS DOLNY Z ŁOŻYSKAMI, PODPARCIE
- (SK) SPODNÝ ZÁVES S LOŽISKAMI, PODPERA
- (EE) ALUMINE LIIGEND LAAGRITEGA, TUGI
- (LT) APATINIS LANKSTAS SU GUOLIAIS, ATRAMA
- (LV) AUGŠĒJĀ VIRĀ AR GULTĻIEM, BALSTS

- (CZ) PANT SPODNÍ LOŽISKOVÝ, S KONZOLOU
- (RO) BALAMA INFERIOARĂ CU LAGĂR DE ALUNECARE, SUPORT
- (HR) DONJA ŠARKA S LEŽAJEVIMA, POTPORANJ
- (RUS) НИЖНЯЯ ПЕТЛЯ С ПОДШИПНИКАМИ, С КРОНШТЕЙНОМ
- (SLO) SPODNJI TEČAJ Z LEŽAJI, PODPORNIK
- (TR) RULMANLI ALT MENTEŞE, DESTEK
- (AR) مفصلة سفلية مع المحامل، دعامة
- (CHN) 配有轴承、支架的下铰链
- (MAL) ENGSEL RENDAH DENGAN BEARING, SOKONGAN
- (H) ALSÓ ZSANÉR CSAPÁGGYAL, MEGTÁMASZTÁSSAL
- (IL) ציר תחתון עם מיסב, ותמיכה
- (BG) ДОННА ПАНТА С ЛАГЕРИ, ПОДДЪРЖАЩА
- (KO) 베어링이 있는 하단 경첩, 지지대
- (SRB) DONJA ŠARKA SA LEŽAJIMA, NOSAČ

Art.	D1	L1	L2	A min./max.	B	C	J	S	CAPACITY	1pc	📦		CODE
	∅			mm			∅	mm	kg	kg	pcs	kg	
AB 50 LSU	50	80	75	50 - 65	40	41	9	8	250	0,78	10	7,8	1700252
AB 70 LSU	68	100	85	50 - 65	60	51	11	10	350	1,75	6	10,5	1700253

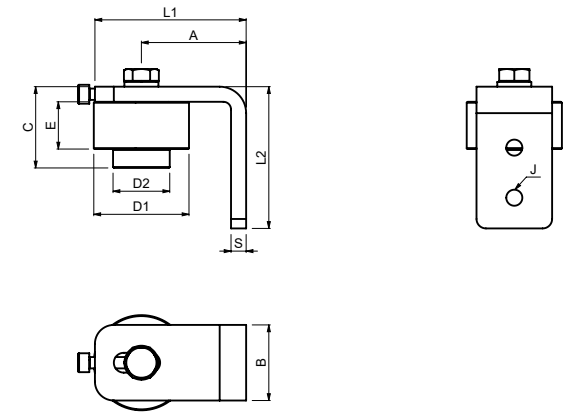

- (GB) UPPER HINGE WITH BEARINGS, SUPPORT
- (D) OBERES SCHARNIER MIT LAGERN, STÜTZE
- (F) CHARNIÈRE SUPÉRIEURE AVEC ROULEMENTS, SUPPORT
- (E) ARTICULACIÓN SUPERIOR CON RODAMIENTOS, SOPORTE
- (P) DOBRADIČA SUPERIOR COM ROLAMENTOS, SUPORTE
- (I) CERNIERA SUPERIORE CON CUSCINETTI, SOSTEGNO
- (DK) ØVERSTE HÆNGSEL MED LEJER, STØTTE
- (NL) BOVENSTE STEUNPUNT MET LAGERS, STEUN
- (N) ØVRE HÆNGSLE MED LAGER, STØTTE
- (S) ØVRE GÅNGJÄRN MED LAGER, STÖD
- (FIN) YLÄSARANA LAAKEREILLA, TUKI
- (PL) ZAWIAS GÓRNY Z ŁOŻYSKAMI, PODPARCIE
- (SK) HORNÝ ZÁVES S LOŽISKAMI, PODPERA
- (EE) ÜLEMINE LIIGEND LAAGRITEGA, TUGI
- (LT) VIRŠUTINIS LANKSTAS SU GUOLIAIS, ATRAMA
- (LV) APAKŠĒJĀ VIRĀ AR GULTĻIEM, BALSTS

- (CZ) PANT HORNÍ LOŽISKOVÝ, S KONZOLOU
- (RO) BALAMA SUPERIOARĂ CU LAGĂR DE ALUNECARE, SUPORT
- (HR) GORNJA ŠARKA S LEŽAJEVIMA, POTPORANJ
- (RUS) ВЕРХНЯЯ ПЕТЛЯ С ПОДШИПНИКАМИ, С КРОНШТЕЙНОМ
- (SLO) ZGORNJI TEČAJ Z LEŽAJI, PODPORNIK
- (TR) RULMANLI ÜST MENTEŞE, DESTEK
- (AR) مفصلة علوية مع المحامل، دعامة
- (CHN) 配有轴承、支架的上铰链
- (MAL) ENGSEL ATAS DENGAN BEARING, SOKONGAN
- (H) FELSŐ ZSANÉR CSAPÁGGYAL, MEGTÁMASZTÁSSAL
- (IL) ציר עליון עם מיסב, ותמיכה
- (BG) ГОРНА ПАНТА С ЛАГЕРИ, ПОДДЪРЖАЩА
- (KO) 베어링이 있는 상단 경첩, 지지대
- (SRB) GORNJA ŠARKA SA LEŽAJIMA, NOSAČ

Art.	D1	D2	L1	L2	A min./max.	B	C	E	J	S	CAPACITY	1pc	📦		CODE
	∅				mm				∅	mm	kg	kg	pcs	kg	
AB 50 ASU	50	30	80	75	50 - 65	40	40	21	9	8	350	0,7	10	7	1700254
AB 70 ASU	68	38	100	85	50 - 65	60	53	31	11	10	550	1,65	6	9,9	1700255



ungalvanized

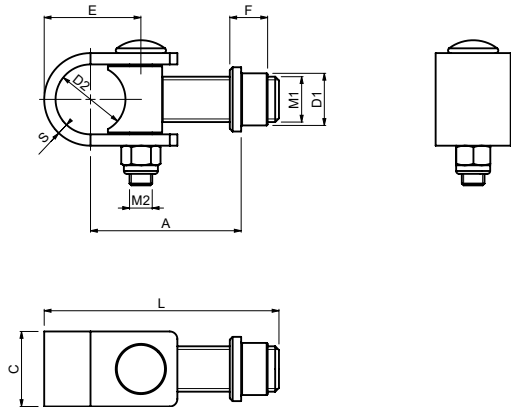

- (GB) ADJUSTABLE „C” CLAMP HINGE WITH NUTS FOR STEEL COLUMNS
- (D) EINSTELLBARES „C” KLEMSCHARNIER MIT MUTTERN FÜR STAHLSÄULEN
- (F) CHARNIÈRE DE SERRAGE RÉGLABLE EN „C” AVEC ÉCROUS POUR COLONNES EN ACIER
- (E) ARTICULACIÓN CON SUJECIÓN EN “C” AJUSTABLE CON TUERCAS PARA COLUMNAS DE ACERO
- (P) DOBRADIÇA AJUSTÁVEL „C” COM PORCAS PARA COLUNAS DE AÇO
- (I) CERNIERA REGOLABILE CON COLLARE A „C” CON DADI PER MONTANTI IN ACCIAIO
- (DK) INDSTILLELIGT “C” KLAMPEHÆNGSEL MED MØTRIKKER TIL STÅLSØJLER
- (NL) VERSTELBARE “C” KLEMSCHARNIER MET MOEREN VOOR STALEN KOLOMMEN
- (N) JUSTERBAR „C” KLEMMHENGSEL MED MUTTERE FOR STÅLSØYLER
- (S) JUSTERBART KLÄMGÅNGJÄRN „C” MED MUTTRAR FÖR STÅLSTOLPAR
- (FIN) SÄÄDETTÄVÄ “C”-KIINNITTIMEN SARANA MUTTEREILLA TERÄSPYLVAISIIN
- (PL) REGULOWANY ZAWIAS Z OBEJMA „C” Z NAKRĘTKAMI DO SŁUPKÓW STALOWYCH
- (SK) NASTAVITELNÝ UPINÁČI ZÁVES V TVARE „C” S MATICAMI PRE OCELOVÉ STĽPY
- (EE) REGULEERITAV “C”-KLAMBRI LIIGEND MUTRITEGA TERASSAMMASTE JAOKS
- (LT) REGULIUOJAMAS „C” FORMOS LANKSTAS SU SPAUSTUVU IR VERŽLEMIS PLIENINIAMS STULPAMS
- (LV) REGULĒJAMA “C” VEIDA SKAVAS VIRA AR UZGRIEŽŅIEM TĒRAUDA STABIEM

- (CZ) PANT REGULOVATELNÝ OSOVÝ S TRĚMENEM, MATKOU PRO KOVOVÉ SLOUPY
- (RO) BALAMA REGLABILĂ DE PRINDERE ÎN FORMĂ DE „C” CU PIULIȚE, PENTRU COLOANE METALICE
- (HR) PRILAGODLJIVA “C” STEZNA ŠARKA SA MATICAMA ZA ČELIČNE STUPOVE
- (RUS) РЕГУЛИРУЕМАЯ ОСЕВАЯ ПЕТЛЯ «С» СО СКОБОЙ И ГАЙКАМИ ДЛЯ МЕТАЛЛИЧЕСКИХ СТОЛБОВ
- (SLO) NASTAVLJIVI TEČAJ S “C” SPONO Z MATICAMI ZA JEKLENE STEBRE
- (TR) ÇELİK SÜTUNLAR İÇİN SOMUNLARLA AYARLANABİLİR „C” KELEPÇELİ MENTEŞE
- (AR) مقصلة مثبتة قابلة للتعديل على شكل حرف “C” مع الصواميل للأعمدة المصنوعة من الصلب
- (CHN) 配有鋼柱螺母的可調節C型夾持較鏈
- (MAL) ENGSEL CENGKAM “C” BOLEH LARAS DENGAN NAT UNTUK KOLUM KELULU
- (H) ÁLLÍTHATÓ C-BEFOGÁSÚ ZSANÉR ANYÁKKAL ACÉL OSZLOPOKHOZ
- (IL) ציר מתכוון עם סגר בצורת C עם אומים למסוקי פלדה
- (BG) РЕГУЛИРУЕМА ПАНТА “C”-ОБРАЗНА СКОБА С ГАЙКА ЗА СТОМАХЕНИ КОЛОНИ
- (KO) 강철 기둥용 조절식 “C”자형 클램프 경첩 및 너트
- (SRB) PODESIVA ŠARKA „C” OBUJIMICE SA NAVRTKAMA ZA ČELIČNE STUBOVE

Art.	M1	A min./max.	C	D1	D2	E	F	M2	L	S	CAPACITY	1pc		CODE	
		mm		Ø		mm					1 pair/kg	kg	pcs	kg	
H 40	M24	55 - 80	40	30	35	48	25	M12	121	6	250	0,77	10	7,7	1700244

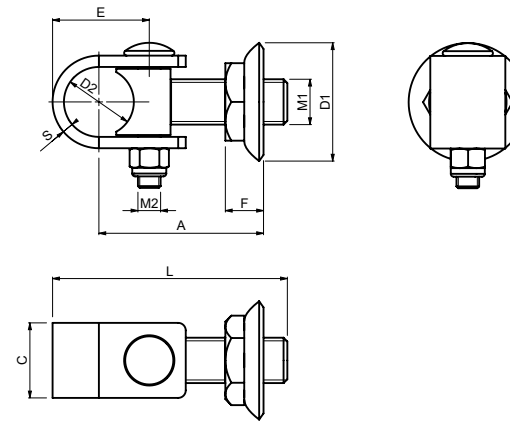

- (GB) ADJUSTABLE „C” CLAMP HINGE WITH NUTS AND WASHER FOR STEEL COLUMNS
- (D) TORBAND FÜR SCHMIEDEEISERNE TÖRE, FÜR EISENSTEHER
- (F) GOND RÉGLABLE À COLLIER AVEC ÉCROUS ET RONDELLE POUR PILIERS EN ACIER
- (E) BISAGNA DE SUJECIÓN EN “C” AJUSTABLE CON PERNOS Y ARANDELA PARA COLUMNAS DE ACERO
- (P) DOBRADIÇA COM GRAMPO EM “C” AJUSTÁVEL COM PORCAS E ARRUELA PARA COLUNAS DE AÇO
- (I) CERNIERA REGOLABILE CON COLLARE A “C”, CON DADI E RONDELLA, PER MONTANTI IN ACCIAIO
- (DK) INDSTILLELIGT “C” KLAMPEHÆNGSEL MED MØTRIKKER OG SPÆNDESKIVE TIL STÅLSØJLER
- (NL) VERSTELBARE “C” KLEM SCHARNIER MET MOEREN EN SLUITRING VOOR STALEN KOLOMMEN
- (N) JUSTERBART “C”-FJÆRHENGSEL MED MUTTERE OG SKIVE TIL STÅLSØYLER
- (S) JUSTERBART “C”-KLÄMGÅNGJÄRN MED MUTTRAR OCH BRICKOR FÖR STÅLSTOLPAR
- (FIN) SÄÄDETTÄVÄ “C”-SARANA MUTTEREILLA JA ALUSLAATALLA TERÄSPYLVAISIIN
- (PL) REGULOWANY ZAWIAS Z OBEJMA „C” Z NAKRĘTKAMI I PODKLADKĄ DO SŁUPKÓW STALOWYCH
- (SK) PÁNT REGULOVATELNÝ OSOVÝ SO STRMEŇOM, MATICOU A PODLOŽKOU PRE KOVOVÉ STĽPY
- (EE) REGULEERITAV “C” KLAMBRI LIIGEND MUTRIT JA SEIBIGA TERASSAMMASTE JAOKS
- (LT) REGULIUOJAMAS „C” FORMOS LANKSTAS SU VERŽLEMIS IR POVERŽLE PLIENINIAMS STULPAMS
- (LV) REGULĒJAMA “C” VEIDA SKAVAS VIRA AR UZGRIEŽŅIEM UN PAPĻAKSNI TĒRAUDA STABIEM

- (CZ) PANT REGULOVATELNÝ OSOVÝ S TRĚMENEM, MATKOU A PODLOŽKOU PRO KOVOVÉ SLOUPY
- (RO) BALAMA REGLABILĂ CLEMĂ „C” CU PIULIȚE ȘI ȘAIBĂ PENTRU COLOANELE DE OȚEL
- (HR) PRILAGODLJIVI ZGLOB „C” OBUJIMICE S MATICOM I PODLOŠKOM, ZA ČELIČNE STUPOVE
- (RUS) РЕГУЛИРУЮЩАЯСЯ ОСЕВАЯ ПЕТЛЯ СО СКОБОЙ, ГАЙКОЙ И ШАЙБОЙ ДЛЯ МЕТАЛЛИЧЕСКИХ СТОЛБОВ
- (SLO) NASTAVLJIVI TEČAJ S “C” SPONO Z MATICAMI IN PODLOŽKO ZA JEKLENE STEBRIČKE
- (TR) ÇELİK SÜTUNLAR İÇİN SOMUN VE CANTALI AYARLANABİLİR “C” KELEPÇE MENTEŞESİ
- (AR) قابل لضبط مع الصموات والحفة الفردة للعمود الفولاذية “C” بمفصل مارم
- (CHN) 鋼柱可調“C”型夾帶螺母墊圈較鏈
- (MAL) ENGSEL PENGAPIT “C” BOLEH LARAS DENGAN NAT DAN SESENDAL UNTUK TIANG KELULU
- (H) ÁLLÍTHATÓ C-BEFOGÁSÚ ZSANÉR ANYÁKKAL ÉS ALÁTÉTEL, ACÉL OSZLOPOKHOZ
- (IL) ציר מתכוון עם הדף
- (BG) РЕГУЛИРУЕМА ПАНТА “C”-ОБРАЗНА СКОБА С ГАЙКА И ШАЙБА ЗА СТОМАХЕНИ КОЛОНИ
- (KO) 강철 기둥용 조절식 “C”자형 클램프 경첩 및 너트, 와셔
- (SRB) PODESIVA ŠARKA „C” OBUJIMICE SA NAVRTKOM I PODLOŠKOM ZA ČELIČNE STUBOVE

Art.	M1	A min./max.	C	D1	D2	E	F	M2	L	S	CAPACITY	1pc		CODE	
		mm		Ø		mm					1 pair/kg	kg	pcs	kg	
HN 40	M24	71 - 100	40	63	35	48	22	M12	121	6	250	0,88	10	8,8	1700108

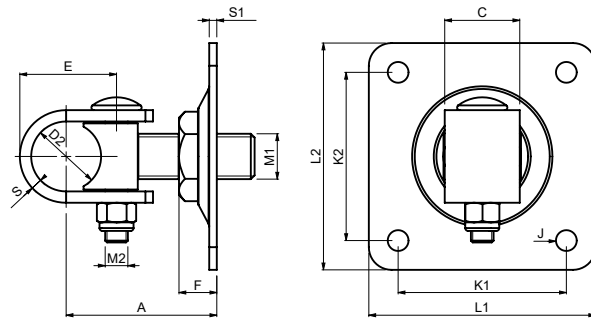

- (GB) ADJUSTABLE „C” CLAMP HINGE WITH PLATE, FIXED
- (D) EINSTELLBARES „C”-KLEMSCHARNIER MIT PLATTE, FEST
- (F) CHARNIÈRE DE SERRAGE RÉGLABLE EN „C” AVEC PLAQUE, FIXE
- (E) ARTICULACIÓN CON SUJECIÓN EN “C” AJUSTABLE CON PLACA, FIJADA
- (P) DOBRADIÇA AJUSTÁVEL DA BRAÇADEIRA „C” COM PLACA, FIXA
- (I) CERNIERA REGOLABILE CON COLLARE A „C” CON PIASTRA, FISSA
- (DK) INDSTILLELIGT “C” KLAMPEHÆNGSEL MED PLADE, FASTGJORT
- (NL) VERSTELBARE “C” KLEMSCHARNIER MET PLAAT, VASTGESCHROEFD
- (N) JUSTERBAR „C” KLEMMEHENGSLER MED PLATTE, FAST
- (S) JUSTERBART KLÄMGÅNGJÄRN „C” MED PLATTA, FAST
- (FIN) SÄÄDETTÄVÄ “C”-KIINNITTIMEN SARANA LEVYLLÄ, PYSYVÄ
- (PL) REGULOWANY ZAWIAS Z OBEJMA „C” Z PŁYTKĄ, MOCOWANY
- (SK) NASTAVITELNÝ KLBOVÝ ZÁVES V TVARE „C” S DOSKOU, PEVNÝ
- (EE) REGULEERITAV “C”-KLAMBRI LIIGENDI PLAADIGA, FIKSEERITUD
- (LT) REGULUOJAMAS „C” FORMOS LANKSTAS SU SPAUSTUVU IR PLOKŠTELE, FIKSUOTAS
- (LV) REGULĒJAMA “C” VEIDA SKAVAS VIRA AR PLĀKŠNI, FIKSĒTA

- (CZ) PANT REGULOVATELNÝ OSOVÝ S TRĚNEMEM, PLOTNOU PRO ZDĚNÉ A KOVOVÉ SLOUPY
- (RO) BALAMA REGLABILĂ DE PRINDERE ÎN FORMĂ DE „C” CU PLACĂ, FIXĂ
- (HR) PRILAGODLJIVA “C” STEZNA ŠARKA S PLOČOM, FIKSIRANI
- (RUS) РЕГУЛИРУЕМАЯ ОСЕВАЯ ПЕТЛЯ «С» СО СКОБОЙ И ПЛАСТИНОЙ, ПРИКРУЧИВАНИЕ ВИНТАМИ
- (SLO) NASTAVLJIVI TEČAJ S “C” SPONO S PLOŠČO, FIKSNI
- (TR) PLAKAYLA AYARLANABİLİR „C” KELEPÇELİ MENTEŞE, SABİT
- (AR) مفصلة مضابك على شكل حرف “C” مع اللوحة، ثابتة
- (CHN) 可调节C型夹持铰链，固定式
- (MAL) ENGSEL CENGKAM “C” BOLEH LARAS DENGAN PLAT, TERIKAT
- (H) ÁLLÍTHATÓ C-BEFOGÁSÚ ZSANÉR LEMEZZEL, RÖGZÍTETT
- (IL) ציר מתכוונן עם סגר צורת C ופלטת, קבוע
- (BG) РЕГУЛИРУЕМА ПАХТА С “C”-ОБРАЗНА СКОБА С ПЛАНКА, ФИКСИРАНА
- (KO) 조절식 “C”자형 클램프 경첩 및 플레이트, 고정식
- (SRB) PODESIVA ŠARKA „C” OBUJIMICE SA PLOČOM, UGRADNJA ZAVRTNJIMA

Art.	M1	L1	L2	A min./max.	L	C	D2	E	F	J	M2	K1	K2	S	S1	CAPACITY	1pc		CODE	
				mm			∅	mm		∅		mm				1 pair/kg	kg	pcs	kg	
HP 40 S	M24	120	120	71 - 99	121	40	35	48	22	11	M12	90	90	6	5	250	1,33	10	13,3	1700245

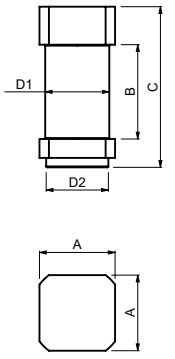
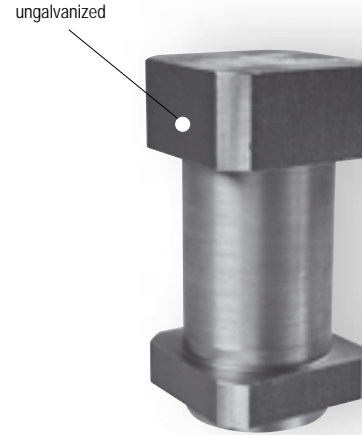

- (GB) GATE JOINT FOR „C” CLAMP TYPE HINGES
- (D) BOLZEN FÜR TORBAND
- (F) AXE DE PORTE POUR GONDS À COLLIER
- (E) JUNTA DE PUERTA PARA BISAGRAS DE TIPO SUJECIÓN “C”
- (P) JUNTA DE PORTÃO PARA DOBRADIÇAS COM GRAMPO EM “C”
- (I) GIUNTO PER CANCELLO PER CERNIERE DEL TIPO CON COLLARE A “C”
- (DK) PORTSAMLING TIL “C” KLAMPE TYPE HÆNGSLER
- (NL) HEK VERBINDINGSSTUK VOOR “C” KLEM TYPE SCHARNIEREN
- (N) PORT SKJØTEPUNKT FOR „C”-FJÆRHENGSLER
- (S) GRINDLED FÖR “C” KLÄMGÅNGJÄRN
- (FIN) PORTIN LIITOS “C”-SARANOIHIN
- (PL) ŁĄCZNIK BRAMY DO ZAWIASÓW Z OBEJMA „C”
- (SK) ČAP OSOVÝ PRE PÁNT
- (EE) VÄRAVAÜHENDUS “C” KLAMBRI-TÜÜPI LIIGENDITE JAOKS
- (LT) VARTUJ JUNGTIŠ „C” FORMOS LANKSTAMS SU SPAUSTUVU
- (LV) VĀRTU SAVIENOJUMS “C” VEIDA SKAVAS VIRĀM

- (CZ) ČEP OSOVÝ PRO PANT
- (RO) ÎMBINARE POARTĂ PENTRU BALAMALELE DE TIP CLEMĂ „C”
- (HR) SPOJNICA VRATA ZA ZGLOB „C” OBUJMICE
- (RUS) ОСЕВАЯ ВТУЛКА ДЛЯ ОСЕВОЙ ПЕТЛИ
- (SLO) SORNİK ZA TEČAJE S “C” SPONO
- (TR) “C” KELEPÇE TİPİ MENTEŞELER İÇİN BAHÇE KAPISI BAĞLANTI PARÇASI
- (AR) “C” وصلة البوابية الخاصة بالمضابك من النوع العائم
- (CHN) “C”型夹铰链门接合
- (MAL) SAMBUNGAN PINTU PAGAR UNTUK ENGSEL JENIS PENGAPIT “C”
- (H) KAPURÖGZÍTŐ-ELEM C-BEFOGÁSÚ ZSANÉROKHOZ
- (IL) בוקסה לציר מתכוונן עם חבק
- (BG) БОЛТ ЗА ПАХТА ЗА “C”-ОБРАЗНА СКОБА
- (KO) “C”자형 클램프 경첩용 게이트 조인트
- (SRB) SPOJNICA VRATA ZA ŠARKU „C” OBUJIMICE

Art.	A	B	C	D1	D2	1pc		CODE	
		mm			∅	kg	pcs	kg	
HP 40	40	45	80	34	33	0,71	10	7,1	1700109

ungalvanized

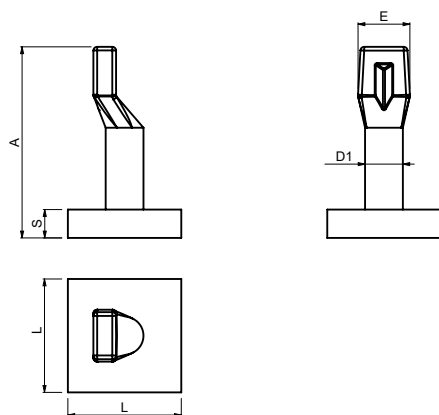
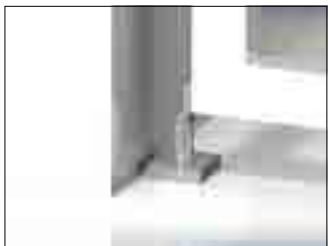
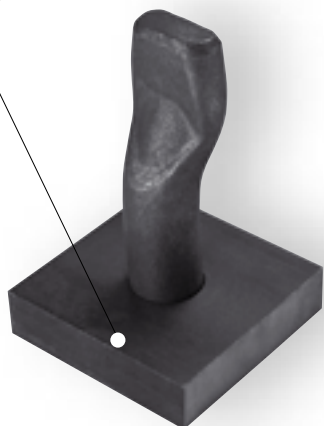

- (GB) LOWER HINGE PIN AND BRACKET
- (D) UNTERES BOLZENBAND FÜR DREHTORE
- (F) GOND À PIVOT INFÉRIEUR ET PLAQUE
- (E) CLAVIJA Y SOPORTE DE BISAGRA INFERIOR
- (P) PINO E SUPORTE DA DOBRADIÇA INFERIOR
- (I) PERNO E STAFFA PER CERNIERA INFERIORE
- (DK) NEDERSTE HÆNGSELSTIFT OG BESLAG
- (NL) ONDERSTE DRAAIPUNT EN STEUNPLAAT
- (N) PINNE OG BRAKETT NEDRE HENGSEL
- (S) UNDRE GÅNGJÄRN STIFT OCH KONSOL
- (FIN) ALAŠARANAN TAPPI JA KANNATIN
- (PL) SWORZEN I WSPORNIK ZAWIASU DOLNEGO
- (SK) PÁNT SPODNÝ
- (EE) ALUMISE LIIGENDI TIHVT JA KLAMBER
- (LT) APATINIO LANKSTO KAIŠTIS IR GEMBĖ
- (LV) APAKŠĒJĀ VIRAS TAPA UN KRONŠTEINS

- (CZ) PANT SPODNÍ
- (RO) BOLȚ ȘI CONSOLĂ BALAMA INFERIOARĂ
- (HR) KLIN I KONZOLA DONJEG ZGLOBA
- (RUS) ПЕТЛЯ НИЖНЯЯ
- (SLO) ZATIČ IN KONZOLA ZA SPODNJI TEČAJ
- (TR) ALT MENTEŞE PİM VE DİRSEĞİ
- (AR) سنادة ومسمار المفصل المنخفض
- (CHN) 下铰链销与支架
- (MAL) PIN DAN PENDAKAP ENGSEL BAWAH
- (H) ALSÓ CSAPOS BEFOGÁS FORGÓAJTÓKHOZ
- (IL) ציר חרות תחתון
- (BG) БОЛТ И СКОБА ЗА ДОЛНА ПАНТА
- (KO) 하단 경첩 핀 및 브래킷
- (SRB) KLIN I KONZOLA DONJE ŠARKE

WE DO IT WITH  
**PASSION**  
OR NOT AT ALL

Art.	D1	A	E	L	S	1pc				CODE
							pcs	kg		
	∅		mm			kg				
SH 20	20	92	27	60	15	0,57	20	11,4	1700114	
SH 24	23	101	33	70	20	0,96	20	19,2	1700115	



Our passion, experience, drive and enthusiasm has created simply the most accurately engineered hardware for cantilever and sliding gates in the world.



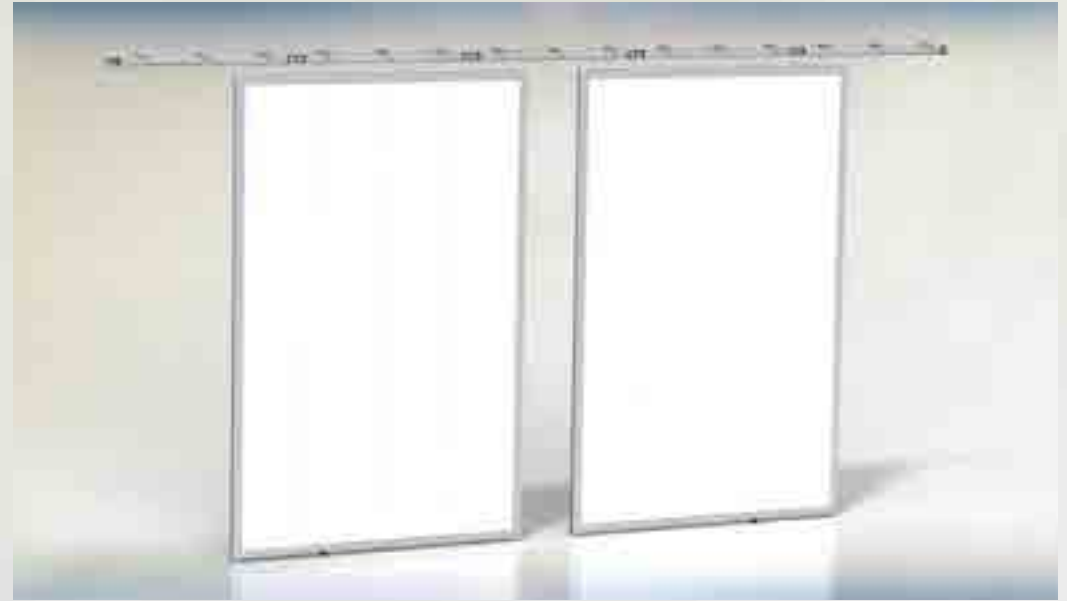

 **SLIDING DOORS**

SLIDING DOOR HARDWARE

COMPONENTS AND DIMENSIONS - 2000 mm SLIDING DOOR

CARRIAGE	GUIDE	SUPPORT	SUPPORT	CARRIAGE	L	A	MAX. CAPACITY 2000 mm (*)	RECOMMENDED
2 SCF	STRELA 33	DB 33 DH 33	12	2	2000	330	70 kg	4
4 SCF	STRELA 33	DB 33 DH 33	12	2	2000	330	120 kg	4
2 SBK	STRELA 42	DB 42 DH 42	12	2	2000	330	160 kg	100
4 SBK	STRELA 42	DB 42 DH 42	12	2	2000	330	220 kg	100
2 SAK	STRELA 57	DB 57 DH 57	12	2	2000	330	220 kg	100
4 SAK	STRELA 57	DB 57 DH 57	12	2	2000	330	320 kg	100

(\*) MAX. CAPACITY WITHOUT ADJUSTABLE SUPPORT PLATE DM

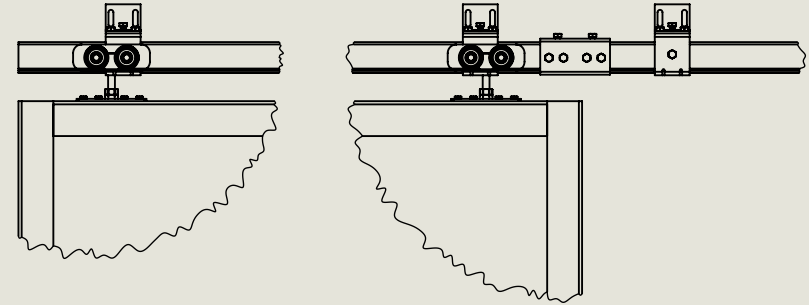

GERMAN STEEL  
WUPPERMANN



HOT DIPPED  
GALVANIZED



EASY  
ASSEMBLING



LINEAR INSTALLATION  
WITHOUT LIMITS



+ 50°C  
TESTED & PROVEN



- 37°C  
TESTED & PROVEN



SUITABLE FOR  
INTERNAL AND  
EXTERNAL  
INSTALLATION



NO WELDING  
NEEDED

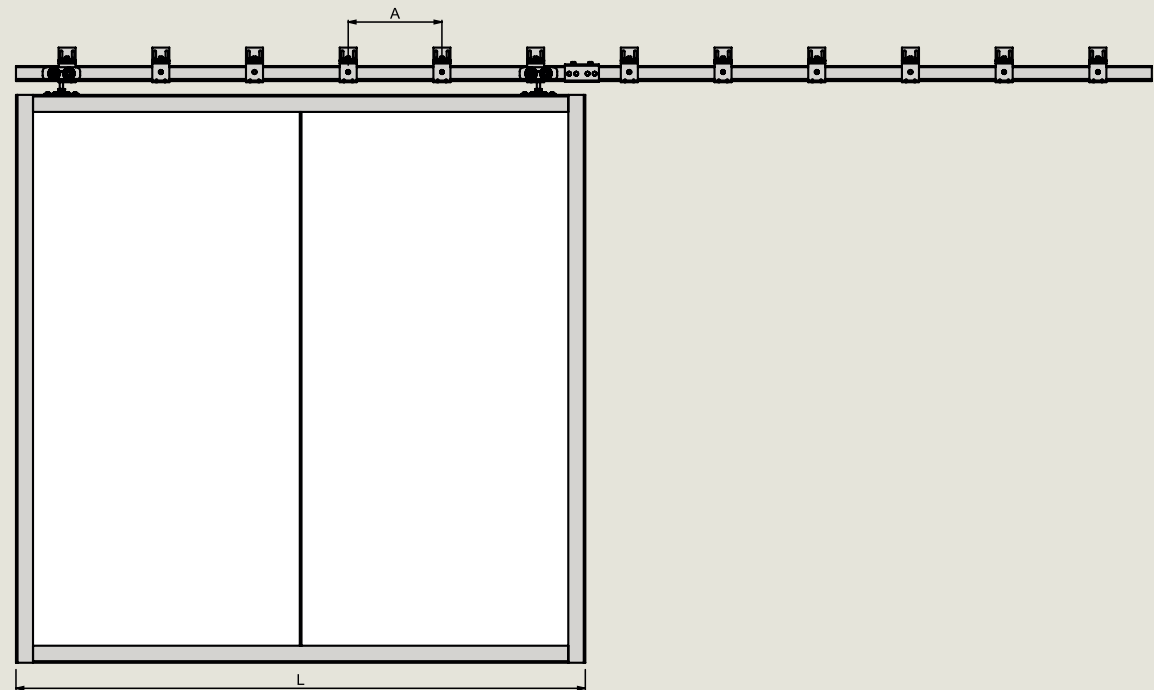

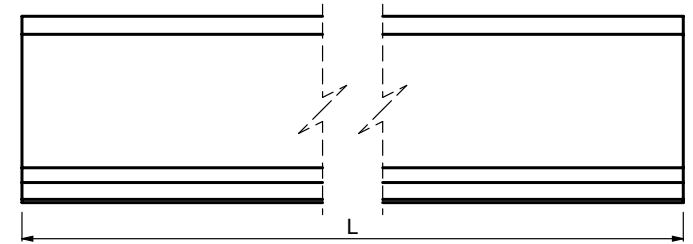
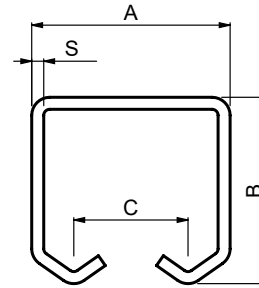

- (GB) „C” PROFILE GUIDE FOR SLIDING DOORS AND SHUTTERS  
 (D) „C” PROFIL FÜR SCHIEBETÜREN- UND TORE  
 (F) GUIDE PROFILÉ EN « C » POUR PORTES COULISSANTES ET VOLETS  
 (E) GUÍA CON PERFIL „C” PARA POSTIGOS Y PUERTAS CORREDERAS  
 (P) GUIA DE PERFIL EM „C” PARA PORTAS E PERSIANAS DESLIZANTES  
 (I) GUIDA CON PROFILO A „C” PER PORTE E SERRANDE SCORREVOLI  
 (DK) „C” PROFILVANGE TIL SKYDEDØRE OG LUKKERE  
 (NL) „C” PROFIEL GELEIDER VOOR SCHUIFDEUREN EN LUIKEN  
 (N) „C”-PROFILSKINNE TIL SKYVEDØRER OG -SKODDER  
 (S) „C” GEJDPROFIL FÖR SKJUTBARA DÖRRAR OCH FÖNSTERLUCKOR  
 (FIN) „C”-PROFILIN OHJAIN LIUKUOVIN JA -LUUKKUIHIN  
 (PL) SZYNA O PROFILU „C” DO DRZWI PRZESUWNYCH I ŻALUZJI  
 (SK) NOSNÝ „C” PROFIL PRE POSUVNÉ ZÁVESNÉ DVERE, BRÁNY A SVETLOLAMY  
 (EE) „C”-PROFILI JUHIK LIUGUSTE JA -LUUKIDE JAOKS  
 (LT) „C” FORMOS PROFILIUOTAS KREIPTUVAS STUMDOMOSIOMS DURIMS IR LANGINĖMS  
 (LV) „C” VEIDA PROFILS BĪDĀMĀJĀM DURVĪM UN AIZBĪDĒJIEM

- (CZ) ŠINA „C” PROFIL PRO POSUVNÉ ZAVĚŠENÉ DVEŘE, VRATA A SVĚTLOLAMY  
 (RO) GHIDAJ PROFIL „C” PENTRU UȘILE GLISANTE ȘI ÎNCHIZĂTOARE  
 (HR) VODILICA „C” PROFILA, ZA KLIZNA VRATA I ŽALUZINE  
 (RUS) НАПРАВЛЯЮЩИЙ РЕЛЬС / ПРОФИЛЬ «С» ДЛЯ РАЗДВИЖНЫХ ПОДВЕСНЫХ ДВЕРЕЙ, ВОРОТ И ЖАЛЮЗЕЙ  
 (SLO) „C” VODILO ZA DRŠNA VRATA IN ŽALUZIJE  
 (TR) SÜRGÜLÜ KAPILAR VE OPTÜRATÖRLER İÇİN „C” PROFİL KIZAĞI  
 (AR) الأواب والرففت المنزلة “C” دعامة نظلية جانبية  
 (CHN) 滑动门与百叶窗“C”型导轨  
 (MAL) PANDU PROFIL „C” UNTUK PINTU DAN PENUTUP GELONGSOR  
 (H) C-VEZETŐSÍN TOLÓAJTÓKHOZ ÉS ZSILÍPEKHEZ  
 (IL) מסילה עליונה לירותות הזזה, שערות ותרסיסים  
 (BG) „C”-ОБРАЗНА РЕЛІСА ЗА ПЛЪЗГАЩИ ВРАТИ И КАПАЦИ  
 (KO) 슬라이딩 도어 및 셔터를용 “C”자형 프로필 가이드  
 (SRB) VODICA „C” PROFILA ZA KLIZNA VRATA I ŽALUZINE KAPIJE

Art.	A	B	C	S	CARRIAGE	SURFACE FINISH	L/1pc	1pc		CODE	
							mm	kg	pcs		kg
STRELA 33/6	33	31	19	2	2 SCF/4 SCF/2SC/4SC/ 2 SCTS/2 SCTL/4 SCML	GALVANIZED	6000	9,6	20	192	1700133
STRELA 33/4	33	31	19	2	2 SCF/4 SCF/2SC/4SC/ 2 SCTS/2 SCTL/4 SCML	GALVANIZED	4000	6,4	20	128	1720073
STRELA 33/3	33	31	19	2	2 SCF/4 SCF/2SC/4SC/ 2 SCTS/2 SCTL/4 SCML	GALVANIZED	3000	4,5	20	96	1700206
STRELA 33/2	33	31	19	2	2 SCF/4 SCF/2SC/4SC/ 2 SCTS/2 SCTL/4 SCML	GALVANIZED	2000	3,2	20	64	1720075
STRELA 33/1	33	31	19	2	2 SCF/4 SCF/2SC/4SC/ 2 SCTS/2 SCTL/4 SCML	GALVANIZED	1000	1,6	20	32	1720076
STRELA 42/6	42	53	24	2,5	2 SBK/4SBK	GALVANIZED	6000	18	20	360	1700134
STRELA 42/4	42	53	24	2,5	2 SBK/4SBK	GALVANIZED	4000	12	20	240	1720079
STRELA 42/3	42	53	24	2,5	2 SBK/4SBK	GALVANIZED	3000	9	20	180	1700207
STRELA 42/2	42	53	24	2,5	2 SBK/4SBK	GALVANIZED	2000	6	20	120	1720081
STRELA 42/1	42	53	24	2,5	2 SBK/4SBK	GALVANIZED	1000	3	20	60	1720082
STRELA 57/6	57	67	30	3	2 SAK/4SAK	GALVANIZED	6000	27,6	20	552	1700135
STRELA 57/4	57	67	30	3	2 SAK/4SAK	GALVANIZED	4000	18,4	20	368	1720085
STRELA 57/3	57	67	30	3	2 SAK/4SAK	GALVANIZED	3000	13,8	20	276	1700208
STRELA 57/2	57	67	30	3	2 SAK/4SAK	GALVANIZED	2000	9,2	20	184	1720087
STRELA 57/1	57	67	30	3	2 SAK/4SAK	GALVANIZED	1000	4,6	20	92	1720088

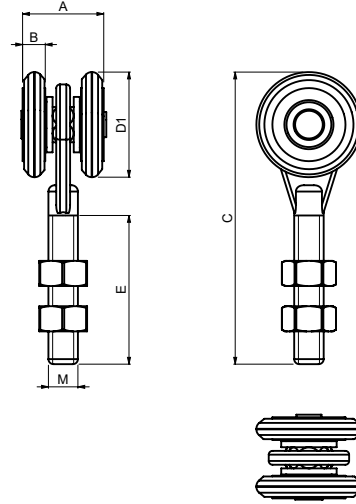

- (GB) TWO WHEELED COVERED BEARING CARRIAGE FOR SLIDING DOORS AND SHUTTERS  
 (D) LAUFWAGEN MIT ZWEI LAUFRÄDERN FÜR FALT- UND SCHIEBETORE  
 (F) CHARIOT DEUX ROUES À ROULEMENT FERMÉ POUR PORTES COULISSANTES ET VOILETS  
 (E) CARRIL DE RODAMIENTO CUBIERTO CON DOS RUEDAS PARA POSTIGOS Y PUERTAS CORREDERAS  
 (P) CORREDIÇA DE ROLAMENTO ABERTO COM DUAS ROLDANAS PARA PORTAS E PERSIANAS DESLIZANTES  
 (I) CARRELLO A CUSCINETTI, CON DUE RUOTE, PER PORTE E SERRANDE SCORREVOLI  
 (DK) TOHJULET DÆKKET LEJESLÆDE TIL SKYVEDØRE OG LUKKERE  
 (NL) DUBBEL WIELENBLOK MET GESLOTEN LAGER VOOR SCHUIFDEUREN EN LUIKEN  
 (N) TOHJULS DEKKET GLIDELAGER FOR SKYVEDØRER OG -SKODDER  
 (S) TVÅHJULAD TÄCKT LAGRAD VAGN FÖR SKJUTBARA DÖRRAR OCH FÖNSTERLUCKOR  
 (FIN) KAKSIPYÖRÄINEN SULJETUN LAAKERIN ALUSTA LIUKUOVIIN JA -LUUKKUIHIN  
 (PL) WÓZEK 2-ROLKOWY Z ZAKRYTYMI ŁOŻYSKAMI DO DRZWI PRZESUWNYCH I ŻALUZJI  
 (SK) VOZÍK DVOJKOLIESKOVÝ LOŽISKOVÝ PRE POSUVNÉ ZÁVESNÉ DVERE, BRÁNY A SVETLOLAMY  
 (EE) KAHERATALLINE KAETUD LAAGRI SUPORT LIUGUSTE JA -LUUKIDE JAOKS  
 (LT) DENGŲAS GUOLIO VĖŽIMĖLIS SU DVIEM RATUKAIS STUMDOMOSIOMS DURIMS IR LANGINĖMS  
 (LV) NOSĒGĒTS NESOŠAIS DIVU RUĻŅU BLOKS BĪDĀMAJĀM DURVĪM UN AIZBĪDNĪEM

- (CZ) VOZÍK DVOUKOLOVÝ LOŽISKOVÝ PRO POSUVNÉ ZÁVĚSNÉ DVEŘE, VRATA A SVĚTLOLAMY  
 (RO) CĂRUCIOR PE DOUĂ ROTI LAGĂR ÎNCHIS PENTRU UȘILE GLISANTE ȘI ÎNCHIZĂTOARE  
 (HR) NOSAČ S DVA KOTAČA PREKRIVENIH LEŽAJA ZA KLIZNA VRATA I ŽALUZINE  
 (RUS) ТЕЛЕЖКА ДВУХОРОЛИКОВАЯ ПОДШИПНИКОВАЯ ДЛЯ РАЗДВИЖНЫХ ПОДВЕСНЫХ ДВЕРЕЙ, ВОРОТ И ЖАЛЮЗИЙ  
 (SLO) VOZIČEK Z DVEMA KOLESOMA S POKRITIM LEŽAJEM ZA DRSNA VRATA IN ŽALUZIJE  
 (TR) SÜRGÜLÜ KAPILAR VE OPTÜRATÖRLER İÇİN İKİ TEKERLEKLİ KAPALI RULMANLI TAŞIYICI  
 (AR) عربة ذات محامل مغلقة مزودة بعجلتين للأبواب والرفوف  
 (CHN) 滑动门与百叶窗双轮封闭轴承滑架  
 (MAL) PENYORONG BEARING TERTUTUP DUA RODA UNTUK PINTU DAN PENUTUP GELONGSOR  
 (H) KÉTGYÖRGÖS ZÁRTCSAPÁGYAS FUTÓKOCSI TOLÓAJTÓKHOZ ÉS ZSILÍPEKHEZ  
 (IL) עגלה תלת-גללים מוגנת עם שתי גללים מוסתרים  
 (BG) КОЛИЧКА С ДВЕ РОЛКИ И КАПСУЛОВАНИ ЛАГЕРИ ЗА ПЛЪЗГАЩИ ВРАТИ И КАПАЦИ  
 (KO) 슬라이딩 도어 및 셔터를 이중 휠 차폐식 베어링 이송대  
 (SRB) NOSAČ SA DVA TOČKIČA PREKRIVENIH LEŽAJA ZA KLIZNA VRATA I ŽALUZINE KAPLJE

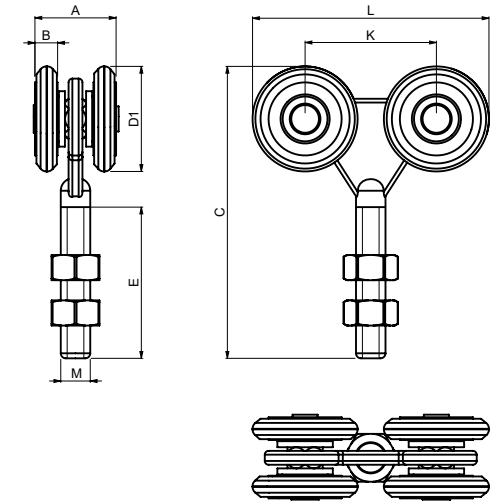

- (GB) FOUR WHEELED COVERED BEARING CARRIAGE FOR SLIDING DOORS AND SHUTTERS  
 (D) LAUFWAGEN MIT VIER LAUFRÄDERN FÜR FALT- UND SCHIEBETORE  
 (F) CHARIOT QUATRE ROUES À ROULEMENT FERMÉ POUR PORTES COULISSANTES ET VOILETS  
 (E) CARRIL DE RODAMIENTO CUBIERTO CON CUATRO RUEDAS PARA POSTIGOS Y PUERTAS CORREDERAS  
 (P) CORREDIÇA DE ROLAMENTO COBERTO COM QUATRO ROLDANAS PARA PORTAS E PERSIANAS DESLIZANTES  
 (I) CARRELLO A CUSCINETTI, CON QUATTRO RUOTE, PER PORTE E SERRANDE SCORREVOLI  
 (DK) FIREHJULET DÆKKET LEJESLÆDE TIL SKYVEDØRE OG LUKKERE  
 (NL) VIERVOUDIG WIELENBLOK MET GESLOTEN LAGER VOOR SCHUIFDEUREN EN LUIKEN  
 (N) FIREHJULS DEKKET GLIDELAGER FOR SKYVEDØRER OG -SKODDER  
 (S) FYRHJULAD TÄCKT LAGRAD VAGN FÖR SKJUTBARA DÖRRAR OCH FÖNSTERLUCKOR  
 (FIN) NELIPYÖRÄINEN SULJETUN LAAKERIN ALUSTA LIUKUOVIIN JA -LUUKKUIHIN  
 (PL) WÓZEK 4-ROLKOWY Z ZAKRYTYMI ŁOŻYSKAMI DO DRZWI PRZESUWNYCH I ŻALUZJI  
 (SK) VOZÍK ŠTVORKOLIESKOVÝ LOŽISKOVÝ PRE POSUVNÉ ZÁVĚSNÉ DVERE, BRÁNY A SVETLOLAMY  
 (EE) NELJARATALLINE KAETUD LAAGRI SUPORT LIUGUSTE JA -LUUKIDE JAOKS  
 (LT) DENGŲAS GUOLIO VĖŽIMĖLIS SU KETURIAIS RATUKAIS STUMDOMOSIOMS DURIMS IR LANGINĖMS  
 (LV) NOSĒGĒTS NESOŠAIS ČETRU RUĻŅU BLOKS BĪDĀMAJĀM DURVĪM UN AIZBĪDNĪEM

- (CZ) VOZÍK ČTYŘKOLOVÝ LOŽISKOVÝ PRO POSUVNÉ ZÁVĚSNÉ DVEŘE, VRATA A SVĚTLOLAMY  
 (RO) CĂRUCIOR PE PATRU ROTI LAGĂR ÎNCHIS PENTRU UȘILE GLISANTE ȘI ÎNCHIZĂTOARE  
 (HR) NOSAČ S ČETIRI KOTAČA PREKRIVENIH LEŽAJA ZA KLIZNA VRATA I ŽALUZINE  
 (RUS) ТЕЛЕЖКА ЧЕТЫРЕХОРОЛИКОВАЯ ПОДШИПНИКОВАЯ ДЛЯ РАЗДВИЖНЫХ ПОДВЕСНЫХ ДВЕРЕЙ, ВОРОТ И ЖАЛЮЗИЙ  
 (SLO) VOZIČEK S ŠTIRIMI KOLESI S POKRITIM LEŽAJEM ZA DRSNA VRATA IN ŽALUZIJE  
 (TR) SÜRGÜLÜ KAPILAR VE OPTÜRATÖRLER İÇİN DÖRT TEKERLEKLİ KAPALI RULMANLI TAŞIYICI  
 (AR) عربة ذات محامل مغلقة مزودة بأربع عجلات للأبواب والرفوف  
 (CHN) 滑动门与百叶窗四轮封闭轴承滑架  
 (MAL) PENYORONG BEARING TERTUTUP EMPAT RODA UNTUK PINTU DAN PENUTUP GELONGSOR  
 (H) NÉGYGYÖRGÖS ZÁRTCSAPÁGYAS FUTÓKOCSI TOLÓAJTÓKHOZ ÉS ZSILÍPEKHEZ  
 (IL) עגלה תלת-גללים מוגנת עם ארבע גללים מוסתרים  
 (BG) КОЛИЧКА С ЧЕТИРИ РОЛКИ И КАПСУЛОВАНИ ЛАГЕРИ ЗА ПЛЪЗГАЩИ ВРАТИ И КАПАЦИ  
 (KO) 슬라이딩 도어 및 셔터를 이중 휠 차폐식 베어링 이송대  
 (SRB) NOSAČ SA ČETIRI TOČKIČA PREKRIVENIH LEŽAJA ZA KLIZNA VRATA I ŽALUZINE KAPLJE

Art.	D1	A	B	C	E	M	GUIDE	CAPACITY	1pc		CODE	
	Ø							kg	kg	pcs	kg	
		mm										
2 SBK	42	33	9	115	60	M12	STRELA 42	180	0,29	20	5,8	1700122
2 SAK	55	41	12	152	80	M20	STRELA 57	380	0,79	8	6,32	1700123

Art.	D1	A	B	C	E	M	E	K	L	M	GUIDE	CAPACITY	1pc		CODE	
	Ø											kg	kg	pcs	kg	
		mm														
4 SBK	42	33	9	115	60	52	94	52	94	M12	STRELA 42	280	0,52	10	5,2	1700124
4 SAK	55	41	12	155	85	60	115	60	114	M20	STRALA 57	580	1,3	4	5,2	1700125



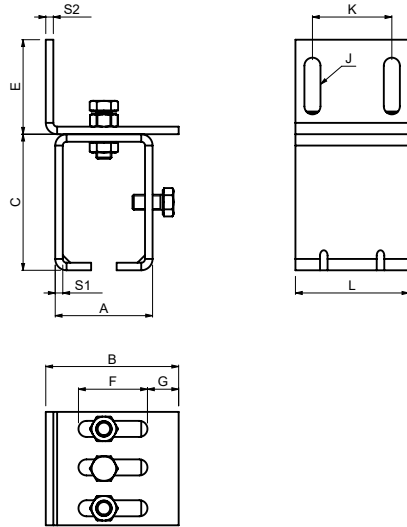

- (GB) ADJUSTABLE WALL SUPPORT BRACKET FOR GUIDE
- (D) HALTERUNG FÜR „C“ PROFIL, SEITLICH REGULIERBAR
- (F) ÉTRIER DE SUPPORT MURAL RÉGLABLE POUR GUIDE
- (E) BASE DE SOPORTE MURAL AJUSTABLE PARA GUÍA
- (P) SUPORTE DE APOIO DE PAREDE REGULÁVEL PARA GUIA
- (I) STAFFA DI SOSTEGNO A PARETE REGOLABILE PER GUIDA
- (DK) INDSTILLELIGT VÆGGSTØTTEBESLAG TIL VANGE
- (NL) VERSTELBARE MUURBEVESTIGINGSPLAAT VOOR GELEIDER
- (N) JUSTERBAR VEGGSTØTTEBRACKET FOR STYRESKINNE
- (S) JUSTERBART TAKSTÖD KONSOL FÖR GEJD
- (FIN) SÄÄDETTÄVÄ SEINÄTUEN KANNATIN OHJAJEEN
- (PL) REGULOWANY WSPORNIK ŚCIENNY DO SZYNY
- (SK) DRŽIAK NOSNÉHO „C“ PROFILU BOČNÝ, REGULOVATELNÝ
- (EE) REGULEERITAVA SEINATOE KLAMBER JUHIKU JAOKS
- (LT) REGULIUOJAMA ATRAMINĖ SIENOS GEMBĖ KREIPTUVUI
- (LV) REGULĒJAMS SIENAS BALSTA KRONSŅTEINS VADOTNEI

- (CZ) DRŽÁK ŠINY „C“ PROFILU BOČNÍ, REGULOVATELNÝ
- (RO) CONSOLĂ REGLABILĂ DE SUPTOR PE PERETE PENTRU GHIDAJ
- (HR) PRILAGODLJIVA ZIDNA KONZOLA ZA VODILICU
- (RUS) КРОНШТЕЙН НАПРАВЛЯЮЩЕГО РЕЛЬСА «С» БОКОВОЙ, РЕГУЛИРУЮЩИЙСЯ
- (SLO) NASTAVLJIVI STENSKI PODPORNİ NOSILEC ZA VODILO
- (TR) KIZAK İÇİN AYARLANABİLİR DUVAR DESTEK DİRSEĞİ
- (AR) سقالة دعمة الحمار القليلة للسيط الخاصة بالنيل
- (CHN) 导轨可调整式支架
- (MAL) PENDAKAP SOKONGAN DINDING BOLEH LARAS UNTUK PANDU
- (H) ÁLLÍTHATÓ FALI VEZETŐSÍN-RÖGZÍTÉS
- (IL) מסלה למסילה להקנה על קיר
- (BG) РЕГУЛИРУЕМА ДЪРЖАЩА СКОБА ЗА РЕЛСА ЗА СТЕНАЕН МОНТАЖ
- (KO) 가이드용 조절식 벽 지지대 브라켓
- (SRB) PODESIVA ZIDNA KONZOLA ZA VODICU

Art.	A	B	C	E	F	G	J	K	L	S1	S2	GUIDE	1pc	CODE		
														kg	pcs	kg
														mm		
DB 33	41	60	50	50	35	10	9x30	40	60	3	4	STRELA 33	0,39	10	3,9	1700136
DB 42	53	69	73	50	35	15	9x30	40	60	4	4	STRELA 42	0,59	10	5,9	1700137
DB 57	66	79	87	50	35	15	9x30	40	60	4	4	STRELA 57	0,7	8	5,6	1700138

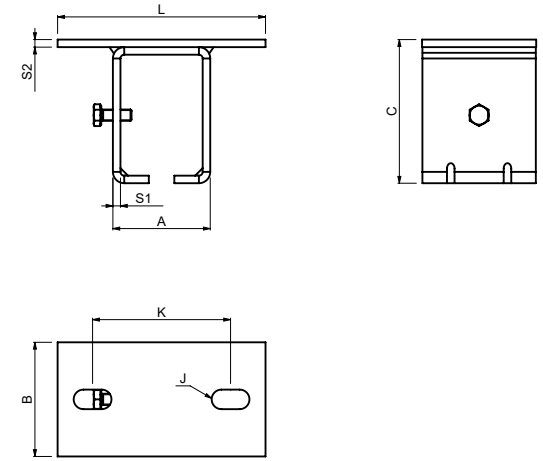
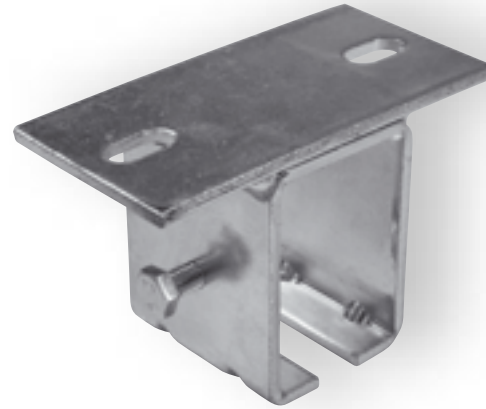

- (GB) ADJUSTABLE CEILING SUPPORT BRACKET FOR GUIDE
- (D) HALTERUNG FÜR „C“ PROFIL, OBEN REGULIERBAR
- (F) ÉTRIER DE SUPPORT DE PLAFOND RÉGLABLE POUR GUIDE
- (E) BASE DE SOPORTE DE TECTO AJUSTABLE PARA GUÍA
- (P) SUPORTE DE APOIO DE TETO REGULÁVEL PARA GUIA
- (I) STAFFA DI SOSTEGNO A SOFFITTO REGOLABILE PER GUIDA
- (DK) INDSTILLELIGT LOFTSTØTTEBESLAG TIL VANGE
- (NL) VERSTELBARE PLAFONDBEVESTIGINGSPLAAT VOOR GELEIDER
- (N) JUSTERBAR TAKSTØTTEBRACKET FOR STYRESKINNE
- (S) JUSTERBART TAKSTÖD KONSOL FÖR GEJD
- (FIN) SÄÄDETTÄVÄ KATTOTUEN KANNATIN OHJAJEEN
- (PL) REGULOWANY WSPORNIK SUFITOWY DO SZYNY
- (SK) DRŽIAK NOSNÉHO „C“ PROFILU HORNÝ, REGULOVATELNÝ
- (EE) REGULEERITAVA LAETOE KLAMBER JUHIKU JAOKS
- (LT) REGULIUOJAMA ATRAMINĖ LUBŲ GEMBĖ KREIPTUVUI
- (LV) REGULĒJAMS GRIESTU BALSTA KRONSŅTEINS VADOTNEI

- (CZ) DRŽÁK ŠINY „C“ PROFILU HORNÍ, REGULOVATELNÝ
- (RO) CONSOLĂ REGLABILĂ DE SUPTOR PE TAVAN PENTRU GHIDAJ
- (HR) PRILAGODLJIVA STROPNA KONZOLA ZA VODILICU
- (RUS) КРОНШТЕЙН НАПРАВЛЯЮЩЕГО РЕЛЬСА «С» ВЕРХНИЙ, РЕГУЛИРУЮЩИЙСЯ
- (SLO) NASTAVLJIVI STROPNI PODPORNİ NOSILEC ZA VODILO
- (TR) KIZAK İÇİN AYARLANABİLİR TAVAN DESTEK DİRSEĞİ
- (AR) سقالة دعمة السقف القليلة للسيط الخاصة بالنيل
- (CHN) 导轨可调整顶式支架
- (MAL) PENDAKAP SOKONGAN SILING BOLEH LARAS UNTUK PANDU
- (H) ÁLLÍTHATÓ MENNYEZETI VEZETŐSÍN-RÖGZÍTÉS
- (IL) מסלה למסילה להקנה לתקרה
- (BG) РЕГУЛИРУЕМА ДЪРЖАЩА СКОБА ЗА РЕЛСА ЗА ТАВАНЕН МОНТАЖ
- (KO) 가이드용 조절식 천정 지지대 브라켓
- (SRB) PODESIVA PLAFONSKA KONZOLA ZA VODICU

Art.	A	B	C	J	K	L	S1	S2	GUIDE	1pc	CODE		
											kg	pcs	kg
											mm		
DH 33	41	59,5	54	11x20	73	110	3	4	STRELA 33	0,43	10	4,3	1700139
DH 42	53	59,5	78	11x20	83	120	4	4	STRELA 42	0,62	10	6,2	1700140
DH 57	66	59,5	93	11x20	93	130	4	4	STRELA 57	0,73	8	5,84	1700141

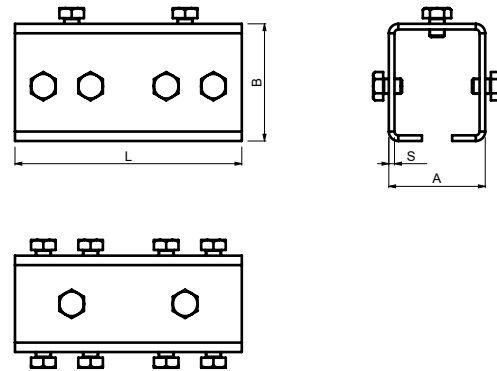
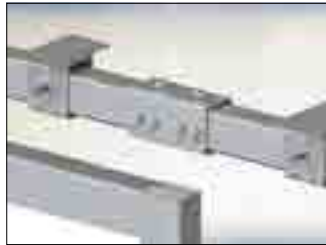

- (GB) „C“ PROFILE GUIDE JOINT BRACKET
- (D) „C“-PROFILFÜHRUNG, GELENKHALTERUNG
- (F) SUPPORT DE JOINT DE GUIDE DE PROFIL EN „C“
- (E) SOPORTE DE UNIÓN DE GUÍA DE PERFIL EN "C"
- (P) GUIA DE PERFIL „C“ GUIA COMUM
- (I) STAFFA DI ACCOPPIAMENTO GUIDA CON PROFILO A „C“
- (DK) BESLAG TIL "C" PROFILVANGFORBINDELSE
- (NL) "C" PROFIELGELEIDER VERBINDINGSSTUK BEVESTIGINGSBEUGEL
- (N) „C“ PROFILSTYRINGSBRACKETT
- (S) "C" GEJDPROFIL FÖR KONSOL
- (FIN) "C"-PROFILISEN OHJAIMEN LIITOKSEN KANNATIN
- (PL) WSPORNIK ŁĄCZĄCY DO SZYNY O PROFILU „C“
- (SK) PRIPOJOVACÍ DRŽIAK PROFILU VODIACEJ LIŠTY V TVARE „C“
- (EE) "C"-PROFIL JUHIKU ÜHENDUSE KLAMBER
- (LT) „C“ FORMOS PROFILIUOTO KREIPTUVO JUNGIAMASIS LAIKIKLIS
- (LV) "C" VEIDA PROFILA SAVIENOTĀJĀBLSTENIS

- (CZ) SPOJKA FIXAČNÍ PRO „C“ PROFIL
- (RO) REAZEM ÎN FORMĂ DE „C“ PENTRU PROFILUL DE GHIDAJ
- (HR) ZGLOBNI NOSAČ "C" PROFILNE VODILICE
- (RUS) ВТУЛОЧНЫЙ КРОНШТЕЙН ДЛЯ НАПРАВЛЯЮЩИХ РЕЛЬСОВ ПРОФИЛЯ «С»
- (SLO) PRITRDLINI NOSILEC Z VODILOM S" C" PROFILOM
- (TR) „C“ PROFIL YATAĞI BAĞLANTI BRAKETİ
- (AR) دعامة مفصل موجه قطاع على شكل حرف "C"
- (CHN) C型导向关节托臂
- (MAL) PENDAKAP TERCANTUM PANDU PROFIL "C"
- (H) C-VEZETŐSÍN ÖSSZEKÖTŐELEM
- (IL) פרופיל מוביל צורת C עם סגר פת
- (BG) СВЪРЗВАЩА СКОБА ЗА "C"-ОБРАЗНА РЕЛСА
- (KO) "C"차형 프로필 가이드 조인트 브래킷
- (SRB) NOSAČ SPOJNICE ZA VODIČU „C“ PROFILA

Art.	L	A	B	S	GUIDE	1pc	Image		CODE
						kg	pcs	kg	
							mm		
AG 33	120	42	40	3	STRELA 33	0,43	10	4,3	1700310
AG 42	120	51	62	3	STRELA 42	0,58	10	5,8	1700311
AG 57	120	64	76	3	STRELA 57	0,71	8	5,68	1700312

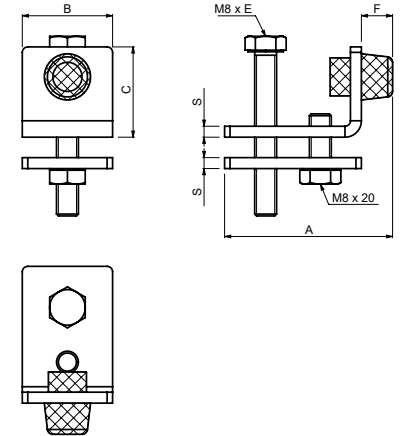

- (GB) INTERNAL GUIDE END STOP
- (D) INNENANSCHLAG FÜR „C“ PROFIL
- (F) BUTÉE INTERNE POUR GUIDE
- (E) TOPE FINAL DE GUÍA INTERNA
- (P) BATENTE GUIA INTERNA
- (I) TFERMO DI FINE CORSA DELLA GUIDA INTERNA
- (DK) INTERN VANGEENDESTOP
- (NL) INTERNE GELEIDER EINDSTOP
- (N) ENDESTOPPER TIL INNVEDSTOP SKINNE
- (S) INTERNT GEJDÄNDSTOPP
- (FIN) SISÄINEN OHJAIMEN PÄÄN PYSÄYTIN
- (PL) WEWNĘTRZNY ODBOJNIK SZYNY
- (SK) DORAZ VNÚTORNÝ PRE NOSNÝ „C“ PROFIL
- (EE) SISEJUHIKU OTSALÖPP
- (LT) VIDINIO KREIPTUVO GALINIS RIBOKLIS
- (LV) IEKŠĒJAIS VADOTNES GALA AIZTURIS

- (CZ) DORAZ VNITRNÍ PRO ŠÍNU „C“ PROFIL
- (RO) GHIDAJ CAPĂT FINAL INTERN
- (HR) UNUTARNJI GRANIČNIK VODILICE
- (RUS) ВНУТРЕННИЙ ОГРАНИЧИТЕЛЬ НАПРАВЛЯЮЩЕГО РЕЛЬСА «С»
- (SLO) ZAUSTAVLJALNIK NOTRANJEGA VODILA
- (TR) DAHİLİ KIZAK UÇ TESPİT PARÇASI
- (AR) مانع طرفي داخلي
- (CHN) 内导轨终点挡块
- (MAL) PENYENDAL Hujung Pandu Dalam
- (H) VEZETŐSÍN BELSŐ ÜTKÖZŐ
- (IL) מעצור פנימי למסילה עליונה
- (BG) ВЪТРЕШЕН СТОПЕР ЗА РЕЛСА
- (KO) 내부 가이드 종단 정지대
- (SRB) UNUTRAŠNJI GRANIČNIK VODICE

Art.	A	B	C	E	F	S	GUIDE	1pc	Image		CODE
								kg	pcs	kg	
									mm		
FINISH 33	61	22	22	35	11	3	STRELA 33	0,08	20	1,6	1700225
FINISH 42	61	33	35	60	11	4	STRELA 42	0,15	20	3	1700226
FINISH 57	62	40	36	75	11	5	STRELA 57	0,22	10	2,2	1700227

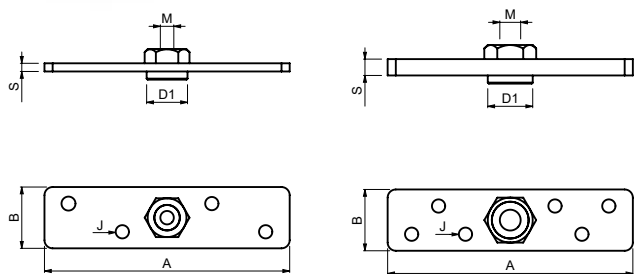

DM 8  
DM 12

DM 20

- (GB) HEIGHT ADJUSTABLE SUPPORT PLATE FOR SLIDING DOORS AND SHUTTERS
- (D) FLÜGELHALTERUNG MIT MUTTER, VERSTELLBAR
- (F) PLATINE DE SUPPORT RÉGLABLE EN HAUTEUR POUR PORTES COULISSANTES ET VOLETS
- (E) PLATO DE SOPORTE CON ALTURA REGULABLE PARA POSTIGOS Y PUERTAS CORREDERAS
- (P) PLACA DE APOIO DE ALTURA AJUSTÁVEL PARA PORTAS E PERSIANAS DESLIZANTES
- (I) PIASTRA DI SOSTEGNO AD ALTEZZA REGOLABILE PER PORTE E SERRANDE SCORREVOLI
- (DK) HØJDEINDSTILLELIG STØTTEPLADE TIL SKYVEDØRE OG LUKKERE
- (NL) VERSTELBARE STEUNPLAAT VOOR SCHUIFDEUREN EN LUIKEN
- (N) HØYDEREGULERENDE STØTTEPLATE TIL SKYVEDØRER OG -SKODDER
- (S) STÖDPLATTAN MED JUSTERBAR HÖJD FÖR SKJUTBARA DÖRRAR OCH FÖNSTERLUCKOR
- (FIN) KORKEUDEN SÄÄTTÄMISEN MAHDOLLISTAVA TUKILEVY LIUKUOVUIN JA -LUUKUIHIN
- (PL) REGULOWANA W PIONIE PŁYTKA WSPORNIKA DO DRZWI PRZESUWNYCH I ŻALUZJI
- (SK) SPOJOVACIA DOSKA K UCHYTENIU KRÍDLA A VOZÍKA, REGULOVATEĽNÁ
- (EE) REGULĒERITAVA KÕRGUSEGA TUZIPLAAT LIUGUSTE JA -LUUKIDE JAOKS
- (LT) VERTIKALIAI REGULIUJAMA ATRAMINĖ PLOKŠTELĖ STUMDOMOSIOMS DURIMS IR LANGINĖMS
- (LV) BALSTA PLĀKSNE AR REGULĒJAMU AUGSTUMU BĪDĀMAJĀM DURVIM UN AIZBĪDNIEM

- (CZ) DESKA SPOJOVACÍ K UCHYCENÍ KRÍDLA A VOZÍKU, REGULOVATEĽNÁ
- (RO) PLACĂ DE SUPORT REGLABILĂ ÎN ÎNĂLȚIME PENTRU UȘILE GLISANTE ȘI ÎNCHIZĂTOARE
- (HR) VISINSKI PRILAGODLJIVA PLOČA ZA KLIZNA VRATA I ŽALUZINE
- (RUS) ПЛАСТИНА СОЕДИНИТЕЛЬНАЯ ДЛЯ КРЕПЛЕНИЯ ДВЕРНОГО КРЫЛА С ТЕЛЕЖКОЙ, РЕГУЛИРУЮЩАЯСЯ
- (SLO) PO VIŠINI NASTAVLJIVA PODPORNÁ PLOŠČA ZA DRSNÁ VRATA IN ŽALUZJE
- (TR) SÜRGÜLÜ KAPILAR VE OPTÜRATORLER İÇİN YÜKSEKLİĞİ AYARLANABİLİR DESTEK PLAKASI
- (AR) لوحة الدعامة التي يمكن ضبط ارتفاعها للأبواب والرفوف المنزلقة
- (CHN) 滑动门与百叶窗高度可调支撑板
- (MAL) PLAT SOKONGAN KETINGGIAN BOLEH LARAS UNTUK PINTU DAN PENUTUP GELONGSOR
- (H) MAGASSÁG-ÁLLÍTHATÓ RÖGZÍTŐLEMEZ TOAJÁJTÓKHOZ ÉS ZSILUPEKHEZ
- (IL) פלטת חיבור דלתות חזרה מתכוננת
- (BG) РЕГУЛИРУЕМА НА ВИСОЧИНА ОПОРНА ПЛАНКА ЗА ПЛЪЗГАЩИ ВРАТИ И КАПАЦИ
- (KO) 슬라이딩 도어 및 셔터용 높이 조절식 지지판
- (SRB) NOSEĆA PLOČA ZA KLIZNA VRATA I ŽALUZINE KAPLJE PODESIVE VISINE

Art.	D1	A	B	J	M	S	CARRIAGE	1pc	CODE		
									kg	pcs	kg
DM 8	20	120	30	6,5	M8	4	2 SCF/4 SCF/2 SC/4 SC	0,12	20	2,4	1700142
DM 12	20	120	30	6,5	M12	4	2 SBK/4 SBK	0,12	20	2,4	1700143
DM 20	38	180	39	11	M20	8	2 SAK/4 SAK	0,44	10	4,4	1700224

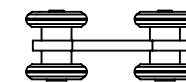
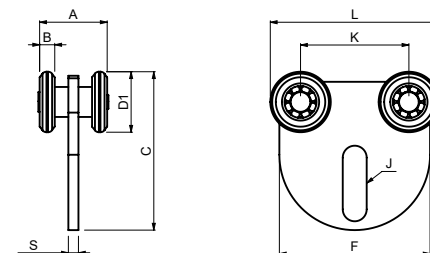

- (GB) UNIVERSAL FOUR WHEELED OPEN BEARING CARRIAGE
- (D) LAUFWAGEN MIT VIER LAUFRÄDERN KUGELGELAGERT, UNIVERSAL
- (F) CHARIOT UNIVERSEL QUATRE ROUES À ROULEMENT OUVERT
- (E) UNIVERSAL PARA CARRIL DE RODAMIENTO ABIERTO DE CUATRO RUEDAS
- (P) CORREDIÇA UNIVERSAL DE ROLAMENTO ABERTO DE QUATRO ROLDANAS
- (I) CARRELLO A CUSCINETTI APERTI, CON QUATTRO RUOTE, UNIVERSALE
- (DK) UNIVERSAL FIREHJULET ÅBEN LEJESLÆDE
- (NL) UNIVERSEEL VIERVOUDIG OPEN WIELBLOK
- (N) UNIVERSAL FIREHJULS ÅPENT GLIDELAGER
- (S) UNIVERSAL FYRHJULAD ÖPPEN LAGRAD VAGN
- (FIN) YLEINEN NELIPYÖRÄINEN AVOIMEN LAAKERIN ALUSTA
- (PL) UNIWERSALNY WÓZEK 4-ROPKOWY Z OTWARTYMI ŁOŻYSKAMI
- (SK) VOZÍK ŠTVORKOLIEČKOVÝ GULČKOVÝ UNIVERZÁLNY
- (EE) UNIVERSAALNE NELJARATTALINE AVATUD LAAGRIGA SUPOORT
- (LT) UNIVERSALUS ATVIRAS GUOLIŲ VĖŽIMĖLIS SU KETURIAIS RATUKAIS
- (LV) UNIVERŠĀLS ATVĒRTS NESOŠAIS ČĒTRU RUĻĻU BLOKS

- (CZ) VOZÍK ČTYRKOLOVÝ KULIČKOVÝ UNIVERZÁLNÍ
- (RO) CĂRUȚIOR PE PATRU ROȚI LAGĂR DESCHIS UNIVERSAL
- (HR) UNIVERZALNI NOSAČ S ČETIRI KOTAČA OTVORENIH LEŽAJA
- (RUS) ТЕЛЕЖКА ЧЕТЫРЕХРОЛИКОВАЯ ШАРИКОВАЯ УНИВЕРСАЛЬНАЯ
- (SLO) UNIVERZALNI VOZIČEK S ŠTIRIMI KOLESI Z ODPRTIM LEŽAJEM
- (TR) UNIVERSEL DÖRT TEKERLEKLİ AÇIK RULMANLI TAŞIYICI
- (AR) عربة بمحامل مفتوحة رباعية العجلات شاملة
- (CHN) 通用四轮开放轴承滑架
- (MAL) PENYORONG BEARING TERBUKA EMPAT RODA UNIVERSAL
- (H) UNIVERZÁLIS, NÉGYGÖRGÖS CSAPÁGYÁS FUTÓKÖCSI
- (IL) עגלה מתלה ארבעה גלגלים מסיב פתוח אוניברסלי
- (BG) УНИВЕРСАЛНА КОЛИЧКА С ЧЕТИРИ РОЛКИ И ОТКРИТИ ЛАГЕРИ
- (KO) 범용 사중 휠 개방식 베어링 이송대
- (SRB) UNIVERZALNI NOSAČ SA ČETIRI TOČKIĆA OTVORENIH LEŽAJA

Art.	D1	A	B	C	F	J	K	L	S	GUIDE	CAPACITY	1pc	CODE		
													kg	kg	pcs
4 SCML	24	25	6	61	60	10x30	42	65	4	STRELA 33	60	0,16	20	3,2	1700132

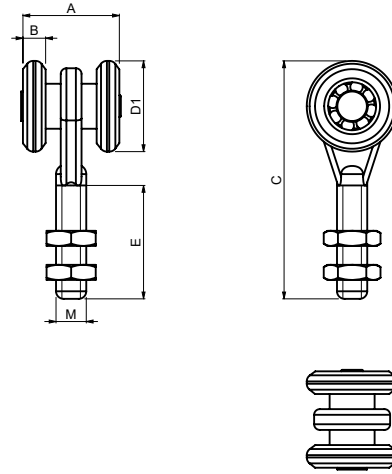

- (GB) TWO WHEELED OPEN BEARING CARRIAGE FOR SLIDING DOORS AND SHUTTERS  
 (D) LAUFWAGEN MIT ZWEI LAUFRÄDERN FÜR FALT-UND SCHIEBETORE  
 (F) CHARIOT DEUX ROUES À ROULEMENT OUVERT POUR PORTES COULISSANTES ET VOILETS  
 (E) CARRIL DE RODAMIENTO ABIERTO CON DOS RUEDAS PARA POSTIGOS Y PUERTAS CORREDERAS  
 (P) CORREDIÇA DE ROLAMENTO ABERTO COM DUAS ROLDANAS PARA PORTAS E PERSIANAS DESLIZANTES  
 (I) CARRELLO A CUSCINETTI APERTI, CON DUE RUOTE, PER PORTE E SERRANDE SCORREVOLI  
 (DK) TOHJULET ÅBEN LEJESLÆDE TIL SKYVEDØRE OG LUKKERE  
 (NL) DUBBEL WIELENBLOK MET OPEN LAGER VOOR SCHUIFDEUREN EN LUIKEN  
 (N) TOHJULS ÅPENT GLIDELAGER FOR SKYVEDØRER OG -SKODDER  
 (S) TVÅHJULAD ÖPPEN LAGRAD VAGN FÖR SKJUTBARA DÖRRAR OCH FÖNSTERLUCKOR  
 (FIN) KAKSIPYÖRÄINEN AVOIMEN LAAKERIN ALUSTA LIUKUUVIIN JA -LUUKKUIHIN  
 (PL) WÓZEK 2-ROLKOWY Z OTWARTYMI ŁOŻYSKAMI DO DRZWI PRZESUWNYCH I ŻALUZJI  
 (SK) VOZÍK DVOUKOLESKOVÝ GULIČKOVÝ PRE POSUVNÉ ZÁVESNÉ DVERE, BRÁNY A SVETLOLAMY  
 (EE) KAHERATTAINE AVATUD LAAGRI SUPORT LIUGUSTE JA -LUUKIDE JAOKS  
 (LT) ATVIRAS GUOLIO VĖŽIMĖLIS SU DVIEM RATUKAIS STUMDOMOSIOMS DURIMS IR LANGINĖMS  
 (LV) ATVERTS NESOŠAIS DIVU RUĻŅU BLOKS BĪDĀMĀJĀM DURVĪM UN AIZBĪDĪNĪEM

- (CZ) VOZÍK DVOUKOLEVÝ KULIČKOVÝ PRO POSUVNÉ ZAVĚŠENÉ DVEŘE, VRATA A SVĚTLOLAMY  
 (RO) CĂRUȚIOR PE DOUĂ ROTI LAGĂR DESCHIS PENTRU UȘILE GLISANTE ȘI ÎNCHIZĂTOARE  
 (HR) NOSAČ S DVA KOTAČA OTVORENIH LEŽAJA ZA KLIZNA VRATA I ŽALUZINE  
 (RUS) ТЕЛЕЖКА ДВУХРОЛИКОВАЯ ШАРИКОВАЯ ДЛЯ РАЗДВИЖНЫХ ПОДВЕСНЫХ ДВЕРЕЙ, ВОРОТ И ЖАЛЮЗИЙ  
 (SLO) VOZIČEK Z DVEMA KOLESOMA Z ODPRTIM LEŽAJEM ZA DRSNÁ VRATA IN ŽALUZIJE  
 (TR) SÜRGÜLÜ KAPILAR VE OPTÜRATÖRLER İÇİN İKİ TEKERLEKLİ AÇIK RULMANLI TAŞIYICI  
 (AR) عربة ذات محامل معلقة مزودة بعجلتين للأبواب والرفوف  
 (CHN) 滑动门与百叶窗双轮开放轴承滑架  
 (MAL) PENYORONG BEARING TERBUKA DUA RODA UNTUK PINTU DAN PENUTUP GELONGSOR  
 (H) KÉTGYÖRGÖS CSAPÁGYÁS FUTÓKOCSI TOLÓAJTÓKHOZ ÉS ZSILÍPEKHEZ  
 (IL) עגלה מותלה שני גלגלים מסיב פחמן  
 (BG) КОЛИЧКА С ДВЕ РОЛКИ И ОТКРИТИ ЛАГЕРИ ЗА ПЛЪЗГАЩИ ВРАТИ И КАПАЦИ  
 (KO) 슬라이딩 도어 및 셔터용 이중 휠 개방식 베어링 이송대  
 (SRB) NOSAČ SA DVA TOČKIĆA OTVORENIH LEŽAJA ZA KLIZNA VRATA I ŽALUZINE KAPLJE

Art.	D1	A	B	C	E	M	GUIDE	CAPACITY	1pc	1pc		CODE
										kg	pcs	
mm												
2 SCF	24	25	6	71	36	M8	STRELA 33	45	0,07	50	3,5	1700116

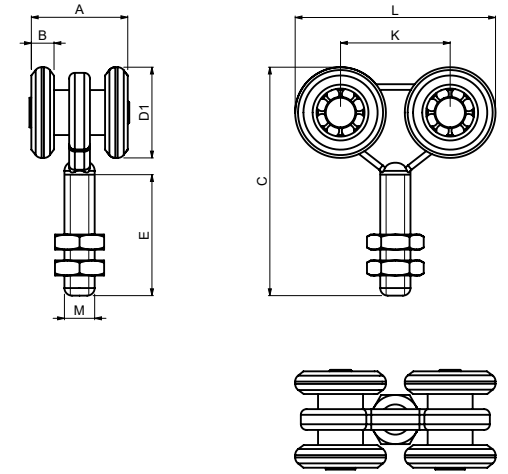

- (GB) FOUR WHEELED OPEN BEARING CARRIAGE FOR SLIDING DOORS AND SHUTTERS  
 (D) LAUFWAGEN MIT VIER LAUFRÄDERN FÜR FALT-UND SCHIEBETORE  
 (F) CHARIOT QUATRE ROUES À ROULEMENT OUVERT POUR PORTES COULISSANTES ET VOILETS  
 (E) CARRIL DE RODAMIENTO ABIERTO CON CUATRO RUEDAS PARA POSTIGOS Y PUERTAS CORREDERAS  
 (P) CORREDIÇA DE ROLAMENTO ABERTO COM QUATRO ROLDANAS PARA PORTAS E PERSIANAS DESLIZANTES  
 (I) CARRELLO A CUSCINETTI APERTI, CON QUATTRO RUOTE, PER PORTE E SERRANDE SCORREVOLI  
 (DK) FIREHJULET ÅBEN LEJESLÆDE TIL SKYVEDØRE OG LUKKERE  
 (NL) VIERVOUDIG WIELENBLOK MET OPEN LAGER VOOR SCHUIFDEUREN EN LUIKEN  
 (N) FIREHJULS ÅPENT GLIDELAGER FOR SKYVEDØRER OG -SKODDER  
 (S) FYRHJULAD ÖPPEN LAGRAD VAGN FÖR SKJUTBARA DÖRRAR OCH FÖNSTERLUCKOR  
 (FIN) NELIPYÖRÄINEN AVOIMEN LAAKERIN ALUSTA LIUKUUVIIN JA -LUUKKUIHIN  
 (PL) WÓZEK 4-ROLKOWY Z OTWARTYMI ŁOŻYSKAMI DO DRZWI PRZESUWNYCH I ŻALUZJI  
 (SK) VOZÍK ŠTVORKOLESKOVÝ GULIČKOVÝ PRE POSUVNÉ ZÁVESNÉ DVERE, BRÁNY A SVETLOLAMY  
 (EE) NELJARATTAINE AVATUD LAAGRI SUPORT LIUGUSTE JA -LUUKIDE JAOKS  
 (LT) ATVIRAS GUOLIO VĖŽIMĖLIS SU KETURIAIS RATUKAIS STUMDOMOSIOMS DURIMS IR LANGINĖMS  
 (LV) ATVERTS NESOŠAIS ČETURU RUĻŅU BLOKS BĪDĀMĀJĀM DURVĪM UN AIZBĪDĪNĪEM

- (CZ) VOZÍK ČTYŘKOLEVÝ KULIČKOVÝ PRO POSUVNÉ ZAVĚŠENÉ DVEŘE, VRATA A SVĚTLOLAMY  
 (RO) CĂRUȚIOR PE PATRU ROTI LAGĂR DESCHIS PENTRU UȘILE GLISANTE ȘI ÎNCHIZĂTOARE  
 (HR) NOSAČ S ČETIRI KOTAČA OTVORENIH LEŽAJA ZA KLIZNA VRATA I ŽALUZINE  
 (RUS) ТЕЛЕЖКА ЧЕТЫРЕХРОЛИКОВАЯ ШАРИКОВАЯ ДЛЯ РАЗДВИЖНЫХ ПОДВЕСНЫХ ДВЕРЕЙ, ВОРОТ И ЖАЛЮЗИЙ  
 (SLO) VOZIČEK S ŠTIRIMI KOLESI Z ODPRTIM LEŽAJEM ZA DRSNÁ VRATA IN ŽALUZIJE  
 (TR) SÜRGÜLÜ KAPILAR VE OPTÜRATÖRLER İÇİN DÖRT TEKERLEKLİ AÇIK RULMANLI TAŞIYICI  
 (AR) عربة ذات محامل معلقة مزودة بأربع عجلات للأبواب والرفوف  
 (CHN) 滑动门与百叶窗四轮开放轴承滑架  
 (MAL) PENYORONG BEARING TERBUKA EMPAT RODA UNTUK PINTU DAN PENUTUP GELONGSOR  
 (H) NÉGYGYÖRGÖS CSAPÁGYÁS FUTÓKOCSI TOLÓAJTÓKHOZ ÉS ZSILÍPEKHEZ  
 (IL) עגלה מותלה ארבעה גלגלים מסיב פחמן  
 (BG) КОЛИЧКА С ЧЕТИРИ РОЛКИ И ОТКРИТИ ЛАГЕРИ ЗА ПЛЪЗГАЩИ ВРАТИ И КАПАЦИ  
 (KO) 슬라이딩 도어 및 셔터용 사중 휠 개방식 베어링 이송대  
 (SRB) NOSAČ SA ČETIRI TOČKIĆA OTVORENIH LEŽAJA ZA KLIZNA VRATA I ŽALUZINE KAPLJE

Art.	D1	A	B	C	E	K	L	M	GUIDE	CAPACITY	1pc	1pc		CODE
												kg	pcs	
mm														
4 SCF	24	25	6	61	31	30	54	M8	STRELA 33	80	0,13	20	2,6	1700119

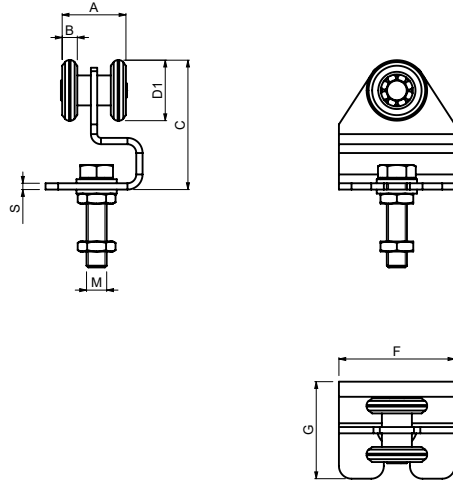

- (GB) TWO WHEELED OPEN BEARING CARRIAGE FOR SLIDING DOORS AND SHUTTERS
- (D) LAUFWAGEN MIT ZWEI LAUFRÄDERN FÜR FALT- UND SCHIEBETÖRE, KUGELGELAGERT
- (F) CHARIOT DEUX ROUES À ROULEMENT OUVERT POUR PORTES COULISSANTES ET VOLETS
- (E) CARRIL DE RODAMIENTO ABIERTO CON DOS RUEDAS PARA POSTIGOS Y PUERTAS CORREDERAS
- (P) CORREDIÇA DE ROLAMENTO ABERTO COM DUAS ROLDANAS PARA PORTAS E PERSIANAS DESLIZANTES
- (I) CARRELLO A CUSCINETTI APERTI, CON DUE RUOTE, PER PORTE E SERRANDE SCORREVOLI
- (DK) TOHJULET ÅBEN LEJESLÆDE TIL SKYDEDØRE OG LUKKERE
- (NL) DUBBEL WIELENBLOK MET OPEN LAGER VOOR SCHUIFDEUREN EN LUIKEN
- (N) TOHJUL ÅPENT GLIDELAGER FOR SKYVEDØRER OG -SKODDER
- (S) TVÅHJULAD ÖPPEN LAGRAD VÄGN FÖR SKJUTBARA DÖRRAR OCH FÖNSTERLÖCKOR
- (FIN) KAKSIPYÖRÄINEN AVOIMEN LAAKERIN ALUSTA LIUKUOVIIN JA -LUUKKUIHIN
- (PL) WÓZEK 2-ROLKOWY Z OTWARTYMI ŁOŻYSKAMI DO DRZWI PRZESUWNYCH I ŻALUZJI
- (SK) VOZÍK DVOJKOLIESKOVÝ GULÍČKOVÝ PRE POSUVNÉ ZÁVESNÉ DVERE, BRÁNY A SVĚTLOLAMY
- (EE) KAHERATTALINE AVATUD LAAGRI SUPORT LIUGUSTE JA -LUUKIDE JAOKS
- (LT) ATVIRAS GUOLIO VEŽIMĖLIS SU DVIEM RATUKAIS STUMDOMOSIOMS DURIMS IR LANGINĖMS
- (LV) ATVĒRTS NESOŠAIS DIVU RUĻŅU BLOKS BĪDĀMAJĀM DURVĪM UN AIZBĪDNĪEM

- (CZ) VOZÍK DVOUKOLOVÝ KULIČKOVÝ PRO POSUVNÉ ZAVĚŠENÉ DVEŘE, VRATA A SVĚTLOLAMY
- (RO) CĂRUCIOR PE DOUĂ ROTI LAGĂR DESCHIS PENTRU UȘILE GLISANTE ȘI ÎNCHIZĂTOARE
- (HR) NOSAČ S DVA KOTAČA OTVORENIH LEŽAJA ZA KLIZNA VRATA I ŽALUZINE
- (RUS) ТЕЛЕЖКА ДВУХРОЛИКОВАЯ ШАРИКОВАЯ ДЛЯ РАЗДВИЖНЫХ ПОДВЕСНЫХ ДВЕРЕЙ, ВОРОТ И ЖАЛЮЗЕЙ
- (SLO) VOZIČEK Z DVEMA KOLESOMA Z ODPRTIM LEŽAJEM ZA DRSNA VRATA IN ŽALUZIJE
- (TR) SÜRGÜLÜ KAPILAR VE OPTÜRATÖRLER İÇİN İKİ TEKERLEKLİ AÇIK RULMANLI TAŞIYICI
- (AR) عربة ذات محامل مطبوخة مزودة بعجلات الأواب والرفات
- (CHN) 滑动门与百叶窗双轮开放轴承滑架
- (MAL) PENYORONG BEARING TERBUKA DUA RODA UNTUK PINTU DAN PENUTUP GELONGSOR
- (H) KÉTGYÖRGŐS CSAPÁGYAS FUTÓKOCSI TOLÓAJTÓKHOZ ÉS ZSILÍPEKHEZ
- (IL) עגלה ממתלה שני גלגלים מים 200
- (BG) КОЛИЧКА С ДВЕ РОЛКИ И ОТКРИТИ ЛАГЕРИ ЗА ПЛЪЗГАЩИ ВРАТИ И КАПАЦИ
- (KO) 슬라이딩 도어 및 셔터용 이중 휠 개방식 베어링 이송대
- (SRB) NOSAČ SA DVA TOČKIĆA OTVORENIH LEŽAJA ZA KLIZNA VRATA I ŽALUZINE KAPLJE

Art.	D1	A	B	C	F	G	M	S	GUIDE	CAPACITY	1pc	Image		CODE
												kg	kg	
2 SC	24	25	6	48	46	36	M8x35	2,5	STRELA 33	35	0,13	20	2,6	1700126

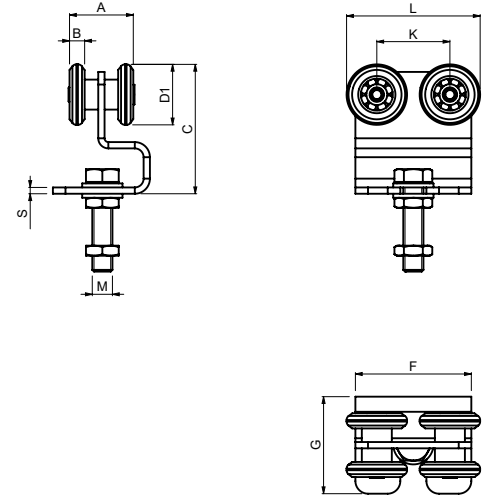

- (GB) FOUR WHEELED OPEN BEARING CARRIAGE FOR SLIDING DOORS AND SHUTTERS
- (D) LAUFWAGEN MIT VIER LAUFRÄDERN FÜR FALT- UND SCHIEBETÖRE, KUGELGELAGERT
- (F) CHARIOT QUATRE ROUES À ROULEMENT OUVERT POUR PORTES COULISSANTES ET VOLETS
- (E) CARRIL DE RODAMIENTO ABIERTO CON CUATRO RUEDAS PARA POSTIGOS Y PUERTAS CORREDERAS
- (P) CORREDIÇA DE ROLAMENTO ABERTO COM QUATRO ROLDANAS PARA PORTAS E PERSIANAS DESLIZANTES
- (I) CARRELLO A CUSCINETTI APERTI, CON QUATTRO RUOTE, PER PORTE E SERRANDE SCORREVOLI
- (DK) FIREHJULET ÅBEN LEJESLÆDE TIL SKYDEDØRE OG LUKKERE
- (NL) VIERVOUDIG WIELENBLOK MET OPEN LAGER VOOR SCHUIFDEUREN EN LUIKEN
- (N) FIREHJUL ÅPENT GLIDELAGER FOR SKYVEDØRER OG -SKODDER
- (S) FYRHJULAD ÖPPEN LAGRAD VÄGN FÖR SKJUTBARA DÖRRAR OCH FÖNSTERLÖCKOR
- (FIN) NELIPYÖRÄINEN AVOIMEN LAAKERIN ALUSTA LIUKUOVIIN JA -LUUKKUIHIN
- (PL) WÓZEK 4-ROLKOWY Z OTWARTYMI ŁOŻYSKAMI DO DRZWI PRZESUWNYCH I ŻALUZJI
- (SK) VOZÍK ŠTVORKOLIESKOVÝ GULÍČKOVÝ PRE POSUVNÉ ZÁVESNÉ DVERE, BRÁNY A SVĚTLOLAMY
- (EE) NELJARATTALINE AVATUD LAAGRI SUPORT LIUGUSTE JA -LUUKIDE JAOKS
- (LT) ATVIRAS GUOLIO VEŽIMĖLIS SU KETURIAIS RATUKAIS STUMDOMOSIOMS DURIMS IR LANGINĖMS
- (LV) ATVĒRTS NESOŠAIS ČETRU RUĻŅU BLOKS BĪDĀMAJĀM DURVĪM UN AIZBĪDNĪEM

- (CZ) VOZÍK ČTYŘKOLOVÝ KULIČKOVÝ PRO POSUVNÉ ZAVĚŠENÉ DVEŘE, VRATA A SVĚTLOLAMY
- (RO) CĂRUCIOR PE PATRU ROTI LAGĂR DESCHIS PENTRU UȘILE GLISANTE ȘI ÎNCHIZĂTOARE
- (HR) NOSAČ S ČETIRI KOTAČA OTVORENIH LEŽAJA ZA KLIZNA VRATA I ŽALUZINE
- (RUS) ТЕЛЕЖКА ЧЕТЫРЕХОЛИКОВАЯ ШАРИКОВАЯ ДЛЯ РАЗДВИЖНЫХ ПОДВЕСНЫХ ДВЕРЕЙ, ВОРОТ И ЖАЛЮЗЕЙ
- (SLO) VOZIČEK S ŠTIRIMI KOLESI Z ODPRTIM LEŽAJEM ZA DRSNA VRATA IN ŽALUZIJE
- (TR) SÜRGÜLÜ KAPILAR VE OPTÜRATÖRLER İÇİN DÖRT TEKERLEKLİ AÇIK RULMANLI TAŞIYICI
- (AR) عربة ذات محامل مطبوخة مزودة بأربع عجلات الأواب والرفات
- (CHN) 滑动门与百叶窗四轮开放轴承滑架
- (MAL) PENYORONG BEARING TERBUKA EMPAT RODA UNTUK PINTU DAN PENUTUP GELONGSOR
- (H) NÉGYGYÖRGŐS CSAPÁGYAS FUTÓKOCSI TOLÓAJTÓKHOZ ÉS ZSILÍPEKHEZ
- (IL) עגלה ממתלה מרבע גלגלים מים 200
- (BG) КОЛИЧКА С ЧЕТИРИ РОЛКИ И ОТКРИТИ ЛАГЕРИ ЗА ПЛЪЗГАЩИ ВРАТИ И КАПАЦИ
- (KO) 슬라이딩 도어 및 셔터용 사중 휠 개방식 베어링 이송대
- (SRB) NOSAČ SA ČETIRI TOČKIĆA OTVORENIH LEŽAJA ZA KLIZNA VRATA I ŽALUZINE KAPLJE

Art.	D1	A	B	C	F	G	K	L	M	S	T	CAPACITY	1pc	Image		CODE
														kg	kg	
4 SC	24	25	6	48	46	36	30	54	M8x35	2,5	STRELA 33	55	0,17	20	3,4	1700127

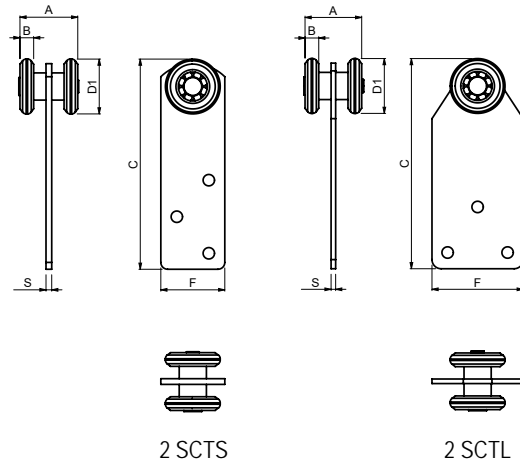

- (GB) TWO WHEELED OPEN BEARING CARRIAGE FOR SLIDING CURTAINS
- (D) LAUFWAGEN MIT ZWEI LAUFRÄDERN FÜR FALT- UND SCHIEBETORE
- (F) CHARIOT DEUX ROUES À ROULEMENT OUVERT POUR RIDEAUX COULISSANTS
- (E) CARRIL DE RODAMIENTO ABIERTO DE DOS RUEDAS PARA CORTINAS CORREDERAS
- (P) CORREDIÇA DE ROLAMENTO ABERTO COM DUAS ROLDANAS PARA CORTINAS DESLIZANTES
- (I) CARRELLO A CUSCINETTI APERTI, CON DUE RUOTE, PER TENDE SCORREVOLI
- (DK) TOHJULET ÅBEN LEJESLÆDE TIL SKYDEGARDINER
- (NL) DUBBEL WIELENBLOK MET OPEN LAGER VOOR SCHERMEN
- (N) TOHJULS ÅPENT GLIDELAGER FOR SKYVEGARDINER
- (S) TVÅHJULAD ÖPPEN LAGRAD VAGN FÖR SKJUTBARA GARDINER
- (FIN) KAKSIPYÖRÄINEN AVOIMEN LAAKERIN ALUSTA LIUKUVERHOIHIN
- (PL) WÓZEK 2-ROLKOWY Z OTWARTYMI ŁOŻYSKAMI DO ŻALUZJI PRZESUWNYCH
- (SK) VOZÍK DVOJKOLIESKOVÝ GULÍČKOVÝ PRE POSUVNÉ ZÁVESNÉ ZÁVESY A PLACHTY
- (EE) KAHERATTALINE AVATUD LAAGRI SUPOORT KARDINATE JAOKS
- (LT) ATVIRAS GUOLIO VEŽIMĖLIS SU DVIEM RATUKAIS STUMDOMOSIOMS UŽUOLAIDOMS
- (LV) ATVĒRTS NESOŠAIS DIVU RUĻŅU BLOKS BĪDĀMO PANEĻU AIZKARIEM

- (CZ) VOZÍK DVOUKOLOVÝ KULIČKOVÝ PRO POSUVNÉ ZÁVĚSNÉ ZÁVĚSY A PLACHTY
- (RO) CĂRUCIOR PE DOUĂ ROTI LAGĂR DESCHIS PENTRU CORTINELE GLISANTE
- (HR) NOSAČ S DVA KOTAČA OTVORENIH LEŽAJA ZA KLIZNE ZASTORE
- (RUS) ТЕЛЕЖКА ДВУХРОЛИКОВАЯ ШАРИКОВАЯ ДЛЯ РАЗДВИЖНЫХ ПОДВЕСНЫХ ЗАНАВЕСОВ И ПЕРЕГОРОДОК
- (SLO) VOZIČEK Z DVEMA KOLESOMA Z ODPRTIM LEŽAJEM ZA DRSNĖ ŽALUZIJĖ
- (TR) SÜRGÜLÜ PERDELER İÇİN İKİ TEKERLEKLİ AÇIK RULMANLI TAŞIYICI
- (AR) عربة بمحامل متحركة مزودة بمحاملين للفتحة المنزلقة
- (CHN) 滑动窗帘双轮开放轴承滑架
- (MAL) PENYORONG BEARING TERBUKA DUA RODA UNTUK LANGSIR GELONGSOR
- (H) KÉTGÖRGÖS CSAPÁGYAS FÜGGÖNYÖKHÓZ
- (IL) גלגלת תמיכה פתוחה עם שני גלגלים לשיי פתוחות חלונות
- (BG) КОЛИЧКА С ДВЕ РОЛКИ И ОТКРИТИ ЛАГЕРИ ЗА ПЛЪЗГАЩИ ПРЕГРАДИ
- (KO) 슬라이딩 도어 및 커튼용 이중 휠 개방식 베어링 이송대
- (SRB) NOSAČ SA DVA TOČKIČKA OTVORENIH LEŽAJA ZA KLIZNE ZAVESE

Art.	D1	A	B	C	F	S	GUIDE	CAPACITY	1pc	Image		CODE
	∅									kg	kg	
2 SCTS	24	25	6	92	28	2	STRELA 33	35	0,08	50	4	1700128
2 SCTL	24	25	6	92	40	2	STRELA 33	35	0,09	50	4,5	1700130

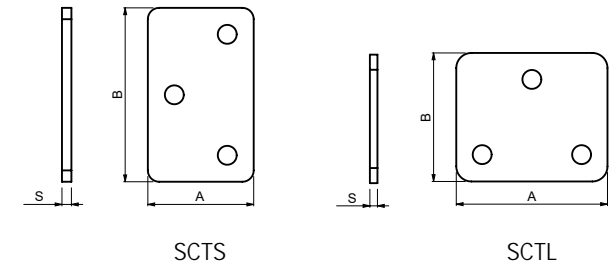

- (GB) FIXING PLATE FOR TWO WHEELED OPEN BEARING CARRIAGE FOR SLIDING CURTAINS
- (D) FIXIERUNGSPLATTE FÜR LAUFWAGEN 2 SCTS, 2 SCTL
- (F) PLATINE DE FIXATION POUR CHARIOT DEUX ROUES À ROULEMENT OUVERT POUR RIDEAUX COULISSANTS
- (E) PLATO DE FIJACIÓN PAR CARRIL DE RODAMIENTO ABIERTO DE DOS RUEDAS PARA CORTINAS CORREDERAS
- (P) PLACA DE FIXAÇÃO PARA CORREDIÇA DE ROLAMENTO ABERTO COM DUAS ROLDANAS PARA CORTINAS DESLIZANTES
- (I) PIASTRA DI FISSAGGIO PER CARRELLO A CUSCINETTI APERTI, CON DUE RUOTE, PER TENDE SCORREVOLI
- (DK) FASTGØRELSESPLAAT TIL TOHJULET ÅBEN LEJESLÆDE TIL SKYDEGARDINER
- (NL) BEVESTIGINGSPLAAT VOOR DUBBEL WIELENBLOK MET OPEN LAGER VOOR SCHUIFSCHERMEN
- (N) FESTEPLATE TIL TOHJULS ÅPENT GLIDELAGER FOR SKYVEGARDINER
- (S) FÄSTPLATTA FÖR TVÅHJULAD ÖPPEN LAGRAD VAGN FÖR SKJUTBARA GARDINER
- (FIN) KIINNITYSLYEVY KAKSIPYÖRÄISEEN AVOIMEN LAAKERIN ALUSTAN LIUKUVERHOIHIN
- (PL) PŁYTKA MOCUJĄCA DO WÓZKA 2-ROLKOWEGO Z OTWARTYMI ŁOŻYSKAMI DO ŻALUZJI PRZESUWNYCH
- (SK) PLÁTNA PRE VOZÍK 2 SCTS, 2 SCTL
- (EE) FIKSEERIMISPLAAT KAHERATTALISE AVATUD LAAGRI SUPORDILE KARDINATE JAOKS
- (LT) TVIRTINIMO PLOKŠTELĖ ATVIRAM GUOLIO VEŽIMĖLIUI SU DVIEM RATUKAIS STUMDOMOSIOMS UŽUOLAIDOMS
- (LV) ATVĒRTA NESOŠĀ DIVU RUĻŅU BLOKA FIKSĒJOŠĀ PLĀKSNE BĪDĀMO PANEĻU AIZKARIEM

- (CZ) PLOTNA PRO VOZÍK 2 SCTS, 2 SCTL
- (RO) PLACĂ DE FIXARE PENTRU CĂRUCIOR PE DOUĂ ROTI LAGĂR DESCHIS PENTRU CORTINELE GLISANTE
- (HR) UGRADBENA PLOČA ZA NOSAČ S DVA KOTAČA OTVORENIH LEŽAJA ZA KLIZNE ZASTORE
- (RUS) ПЛАСТИНА ДЛЯ ДВУХРОЛИКОВОЙ ШАРИКОВОЙ ТЕЛЕЖКИ 2 SCTS, 2 SCTL ДЛЯ РАЗДВИЖНЫХ ПОДВЕСНЫХ ЗАНАВЕСОВ И ПЕРЕГОРОДОК
- (SLO) PRITRILNA PLOŠČA ZA VOZIČEK Z DVEMA KOLESOMA Z ODPRTIM LEŽAJEM ZA DRSNĖ ŽALUZIJĖ
- (TR) İKİ TEKERLEKLİ AÇIK RULMANLI SÜRGÜLÜ PERDE TAŞIYICISI İÇİN SABİTLEME PLAKASI
- (AR) لوحة تثبيت من أجل عربة بمحامل متحركة مزودة بمحاملين للفتحة المنزلقة
- (CHN) 滑动窗帘双轮开放轴承滑架固定板
- (MAL) PLAT PENETAP UNTUK PENYORONG BEARING TERBUKA DUA RODA UNTUK LANGSIR GELONGSOR
- (H) RÖGZITŐLEMEZ A KÉTGÖRGÖS CSAPÁGYAS FÜGGÖNYÖKHÓZ
- (IL) פלטת תמיכה לפתוח חלונות
- (BG) ФИКСИРАЩА ПЛАНКА ЗА КОЛИЧКА С ДВЕ РОЛКИ И ОТКРИТИ ЛАГЕРИ ЗА ПЛЪЗГАЩИ ПРЕГРАДИ
- (KO) 슬라이딩 도어 및 커튼용 이중 휠 개방식 베어링 이송대의 고정판
- (SRB) UGRADNA PLOČA ZA NOSAČ SA DVA TOČKIČKA OTVORENIH LEŽAJA ZA KLIZNE ZAVESE

Art.	A	B	S	CARRIAGE	1pc	Image		CODE
						kg	pcs	
SCTS	28	46	2	2 SCTS	0,02	50	1	1700129
SCTL	40	34	2	2 SCTL	0,02	50	1	1700131

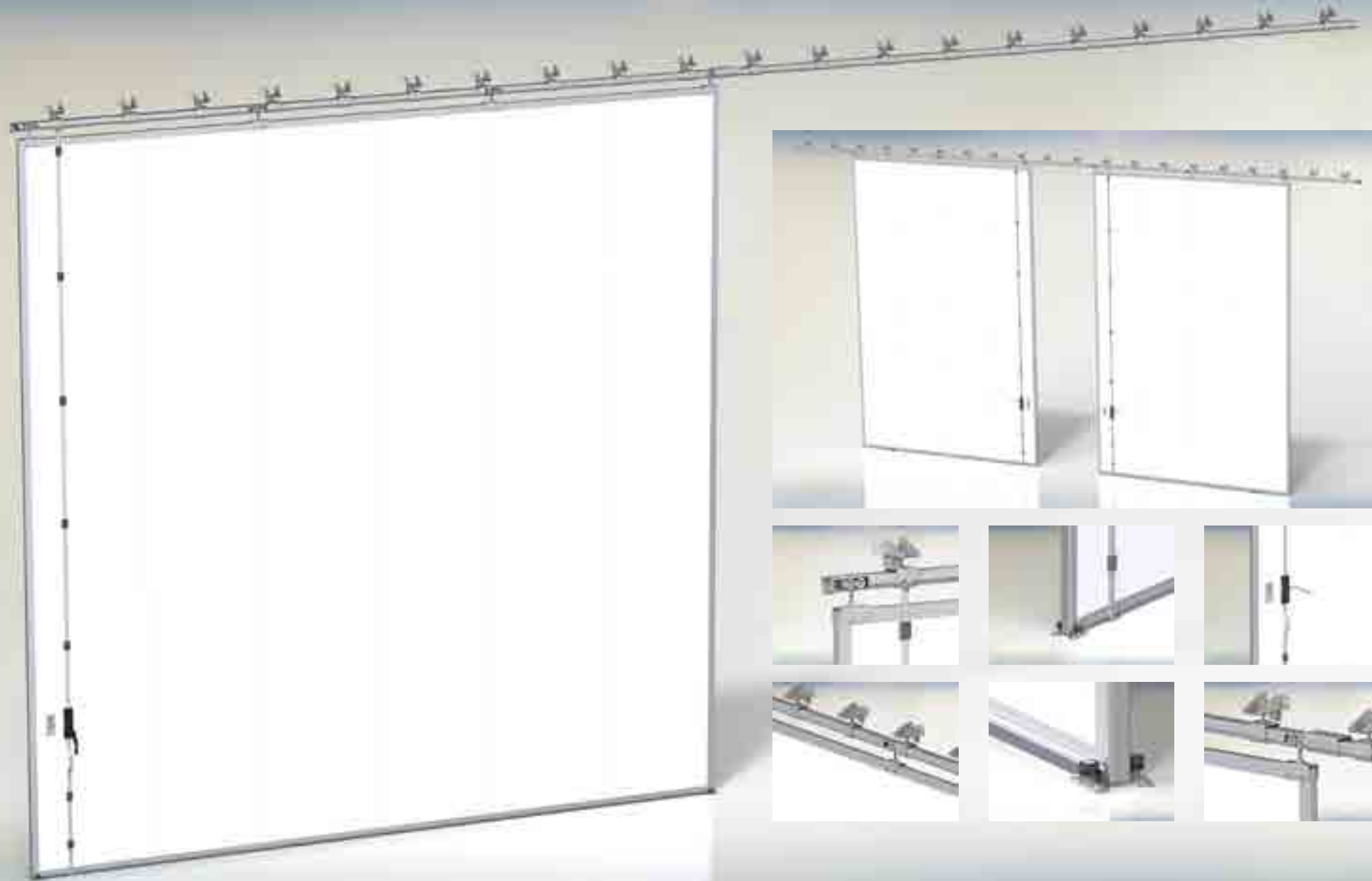

 **SLIDING DOORS**

HARDWARE FOR HEAVY SLIDING DOORS

COMPONENTS & DIMENSIONS									6 m / 960 kg
CARRIAGE	GUIDE	SUPPORT	NUMBER SUPPORT	NUMBER GARIAGE	NUMBER SUPRORT	LENGHT WING	DISTANCE BETWEEN SUPPORT	MAX. CAPACITY WING	
			DC 70/KHL	SPEED C	AD 150	L	A	TO 6000 mm	
			pcs				mm	kg	
SPEED C	STAGE SZ	DC 70/KHL	14	4	4	6000	500	1200	
SPEED C	STAGE SZ	DC 70/KHL	11	4	4	6000	650	960	

COMPONENTS & DIMENSIONS									4 m / 640 kg
CARRIAGE	GUIDE	SUPPORT	NUMBER SUPPORT	NUMBER GARIAGE	NUMBER SUPRORT	LENGHT WING	DISTANCE BETWEEN SUPPORT	MAX. CAPACITY WING	
			DC 70/KHL	SPEED C	AD 150	L	A	TO 4000 mm	
			pcs				mm	kg	
SPEED C	STAGE SZ	DC 70/KHL	10	3	3	4000	500	800	
SPEED C	STAGE SZ	DC 70/KHL	8	3	3	4000	650	640	

COMPONENTS & DIMENSIONS									2 m / 320 kg
CARRIAGE	GUIDE	SUPPORT	NUMBER SUPPORT	NUMBER GARIAGE	NUMBER SUPRORT	LENGHT WING	DISTANCE BETWEEN SUPPORT	MAX. CAPACITY WING	
			DC 70/KHL	SPEED C	AD 150	L	A	TO 2000 mm	
			pcs				mm	kg	
SPEED C	STAGE SZ	DC 70/KHL	5	2	2	2000	500	400	
SPEED C	STAGE SZ	DC 70/KHL	4	2	2	2000	650	320	

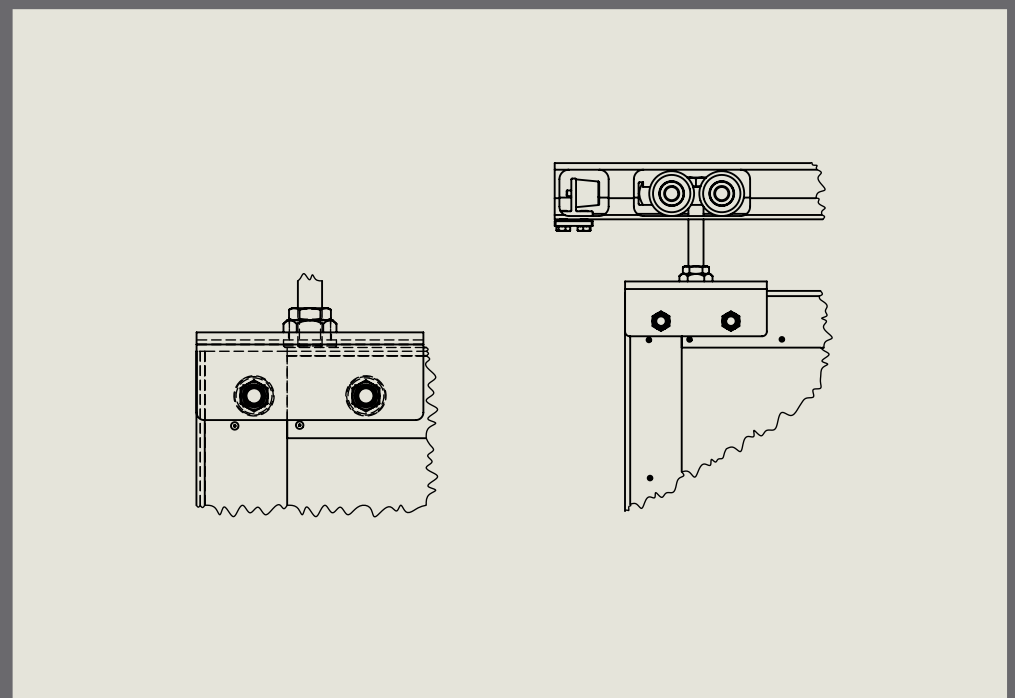

GERMAN STEEL WUPPERMANN



NO WELDING NEEDED

270 g/m<sup>2</sup>

HOT DIPPED GALVANIZED

46 mm

SLIM LEAF



EASY ASSEMBLING

NO LIMIT

LINEAR INSTALLATION WITHOUT LIMITS



+ 50°C TESTED & PROVEN



- 37°C TESTED & PROVEN

INT EXT

SUITABLE FOR INTERNAL AND EXTERNAL INSTALLATION

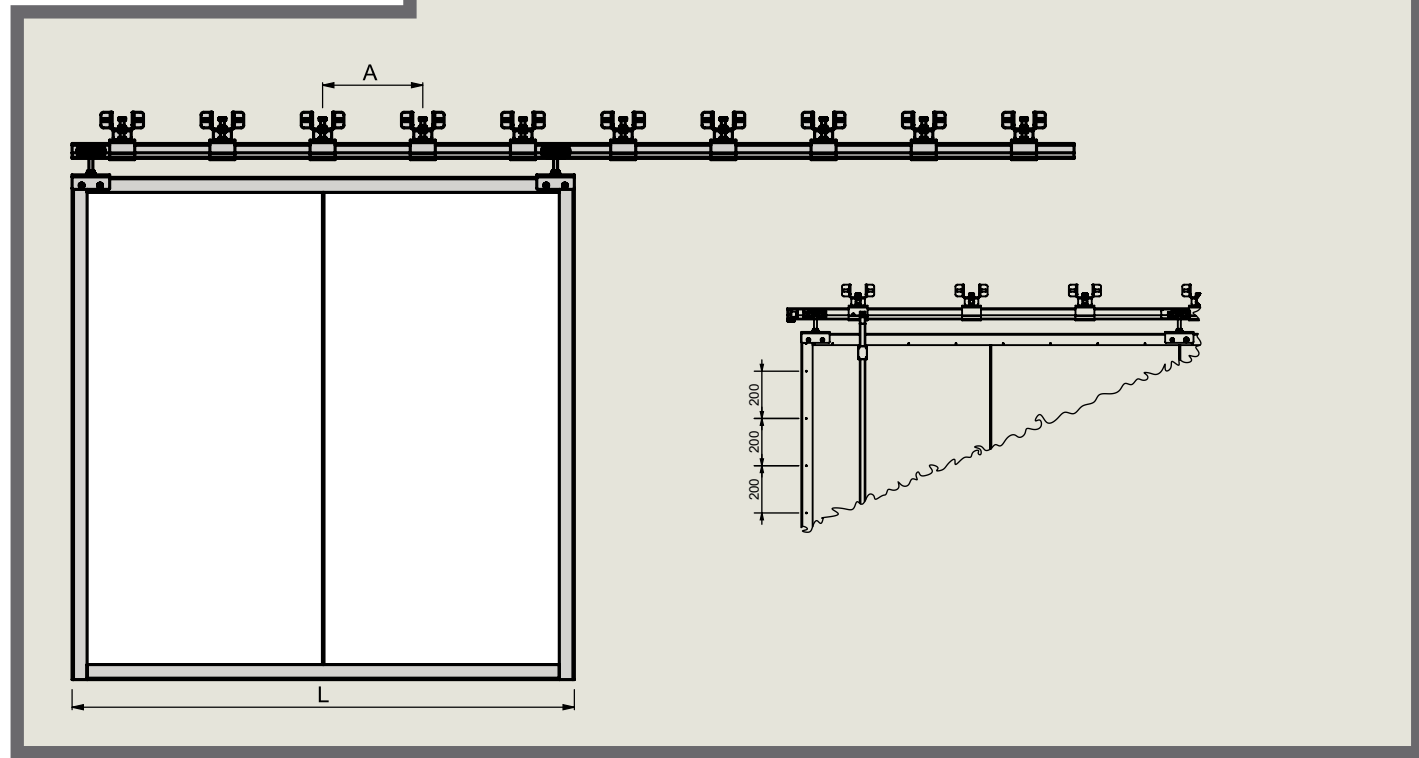



RECOMMENDED INSTALLATION  
CARRIAGES - BRACKET SUPPORT - INSULATED PANELS - „U“ PROFILE

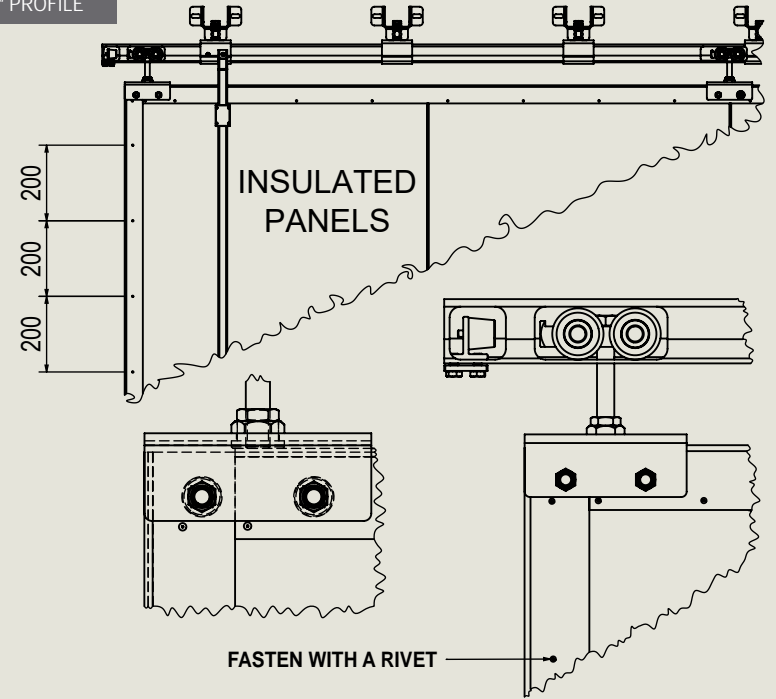
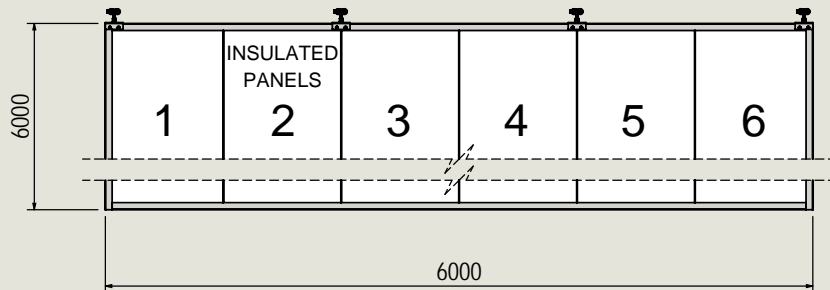
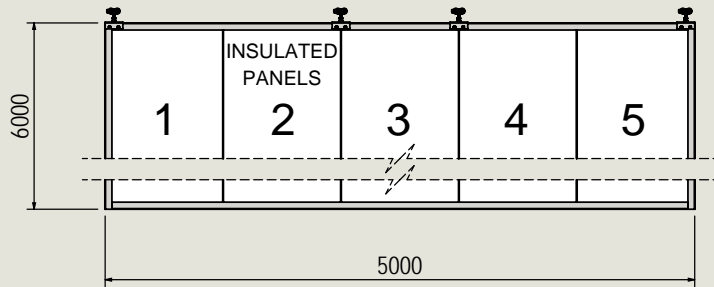
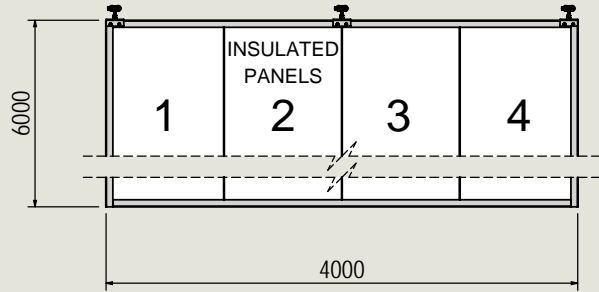
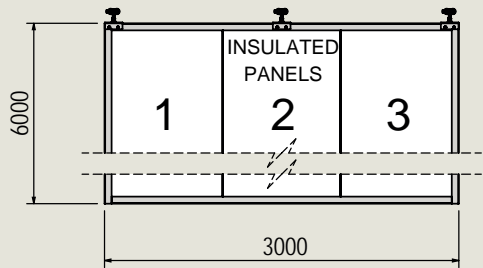

**RIVETING**  
„U“ PROFILE FRAME AND INSULATED PANELS MUST BE FASTEN FROM BOTH SIDE BY RIVET EVERY 200 mm

SAFETY MEASURES - POSITIONING GUIDELINES  
INSULATED PANELS - SUPPORT BRACKETS - CARRIAGES

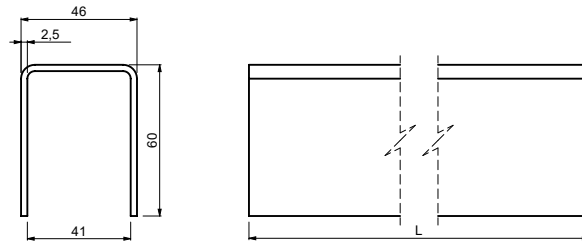
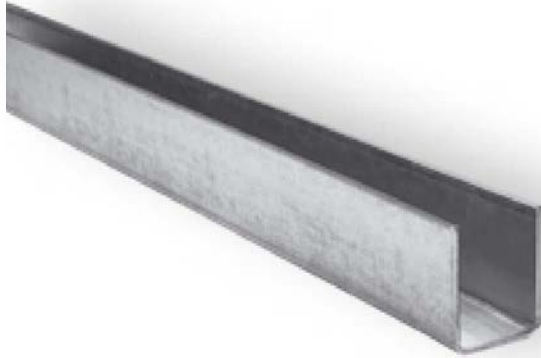

- (GB) „U“ PROFILE FRAME FOR SLIDING DOOR
- (D) „U“-PROFILRAHMEN FÜR SCHIEBETÜR
- (F) CADRE DE PROFIL EN „U“ POUR PORTAIL COULISSANT
- (E) BASTIDOR DE PERFIL EN „U“ PARA PUERTA DESLIZANTE
- (P) MOLDURA DE PERFIL „U“ PARA PORTÃO DESLIZANTE
- (I) TELAIO DAL PROFILO A „U“ PER PORTA SCORREVOLE
- (DK) „U“ PROFILRAMME TIL SKYDEDØR
- (NL) „U“ PROFIELFRAME VOOR SCHUIVENDE DEUR
- (N) „U“ PROFIL RAMME FOR SKYVEDØR
- (S) „U“ PROFILRAM FÖR SKJUTDÖRR
- (FIN) „U“-PROFILINEN KEHYS LIUKUOVEEN
- (PL) RAMA O PROFILU „U“ DO DRZWI PRZESUWNYCH
- (SK) PROFILOVÝ RÁM V TVARE „U“ PRE POSUVNÉ DVERE
- (EE) „U“-PROFIILI RAAM LIUGUKSE JAOKS
- (LT) „U“ FORMOS PROFILIUOTAS RĒMAS STUMDOMOSIOMS DURĪMS
- (LV) „U“ VEIDA PROFILA RĀMIS BĪDĀMAJĀM DURVĪM

- (CZ) „U“ PROFIL RÁM PRO POSUVNÉ VRATA
- (RO) CADRU PROFIL ÎN FORMĂ DE „U“ PENTRU UȘI CULISANTE
- (HR) „U“ PROFILNI OKVIR ZA KLIZNA VRATA
- (RUS) РАМА ПРОФИЛЯ «U» ДЛЯ РАЗДВИЖНЫХ ДВЕРЕЙ
- (SLO) OKVIR Z „U“ PROFILOM ZA DRŠNA VRATA
- (TR) SÜRGÜLÜ KAPI İÇİN „U“ PROFİL ÇERÇEVESİ
- (AR) إطار قطاع على شكل حرف „U“ للباب المنزلقي
- (CHN) 滑动门U型框
- (MAL) BINGKAI PROFIL „U“ UNTUK PINTU GELONGSOR
- (H) U-VEZETŐSÍN TOLÓAJTÓHOZ
- (IL) לוללות הזזה U מסגרת מפרופיל מוביל צורת
- (BG) „U“-ПРОФИЛНА РАМКА ЗА ПЛЪЗГАЩА ВРАТА
- (KO) 슬라이딩 도어용 „U“자형 프로필 프레임
- (SRB) RAM „U“ PROFILA ZA KLIZNA VRATA

Art.	SUPPORT BRACKET	SURFACE FINISH	L/1pc	1pc			CODE
					pcs	kg	
MCD 60/6	AD 150	GALVANIZED	6000	18,54	40	741,6	1720095
MCD 60/4	AD 150	GALVANIZED	4000	13,16	40	526,4	1720096

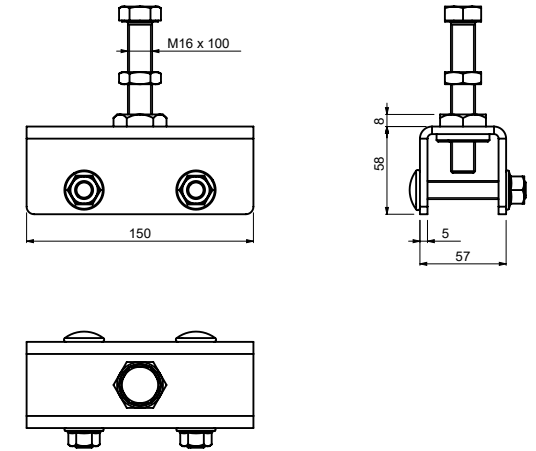

- (GB) UPPER ADJUSTABLE BRACKET SUPPORT FOR „U“ PROFILE FRAME SLIDING DOOR
- (D) OBERE EINSTELLBARE HALTERUNGSSTÜTZE FÜR SCHIEBETÜR MIT „U“-PROFILRAHMEN
- (F) SUPPORT SUPÉRIEUR RÉGLABLE POUR PORTAIL COULISSANT À CADRE PROFILÉ EN „U“
- (E) SOPORTE AJUSTABLE SUPERIOR PARA PUERTA DESLIZANTE CON BASTIDOR DE PERFIL EN „U“
- (P) SUPORTE DE SUPORTE AJUSTÁVEL SUPERIOR PARA PORTÃO DESLIZANTE DE MOLDURA DE PERFIL „U“
- (I) SOSTEGNO STAFFA SUPERIORE REGOLABILE PER PORTA SCORREVOLE CON TELAIO DAL PROFILO A „U“
- (DK) ØVERSTE INDSTILLELIGE BESLAGSTØTTE TIL „U“ PROFILRAMME SKYDEDØR
- (NL) BOVENSTE VERSTELBARE BEVESTIGINGSBEUGELSTEUN VOOR „U“ PROFIELFRAME SCHUIVENDE DEUR
- (N) ØVRE JUSTERBARE BRACKETSTØTTE FOR „U“ PROFILRAMME SKYVEDØR
- (S) ÖVRE JUSTERBART KONSOLSTÖD FÖR „U“ PROFILRAM SKJUTDÖRR
- (FIN) SÄÄDETTÄVÄ KANNATTIMEN YLÄTUKI „U“-PROFILINEN KEHYS LIUKUOVEEN
- (PL) GÓRNY REGULOWANY WSPORNIK DO RAMY O PROFILU „U“ DO DRZWI PRZESUWNYCH
- (SK) HORNÁ NASTAVITELNÁ KONZOLA PRE POSUVNÉ DVERE PRE PROFILOVÉ RÁMY V TVARE „U“
- (EE) ÜLEMINE REGULEERITAV KLAMBRITUGI „U“-PROFIILI RAAMI LIUGUKSE JAOKS
- (LT) VIRŠUTINĖ REGULIUOJAMA LAIKIKLIO ATRAMA STUMDOMOSIOMS DURĪMS SU „U“ FORMOS PROFILIUOTU RĒMU
- (LV) REGULĒJAMS AUGŠĒJĀIS BALSTA KRONŠTEINS BĪDĀMAJĀM DURVĪM AR „U“ VEIDA PROFILA RĀMI

- (CZ) DRŽÁK „U“ PROFILU PRO POSUVNÉ VRATA
- (RO) SUPORT SUPERIOR REGLABIL ÎN CONSOLĂ PENTRU UȘI CULISANTE CU CADRU DE PROFIL ÎN FORMĂ DE „U“
- (HR) GORNJI PRILAGODLJIVI POTPORANI NOSAČA ZA KLIZNA VRATA „U“ PROFILNOG OKVIRA
- (RUS) ВЕРХНИЙ РЕГУЛИРУЕМЫЙ ОПОРНЫЙ КРОНШТЕЙН ДЛЯ РАМЫ РАЗДВИЖНЫХ ДВЕРЕЙ, ПРОФИЛЬ «U»
- (SLO) ZGORNJI NASTAVLJIVI PODPORNI NOSILEC ZA OKVIR Z „U“ PROFILOM ZA DRŠNA VRATA
- (TR) „U“ PROFİL ÇERÇEVESİ SÜRGÜLÜ KAPI İÇİN ÜST AYARLANILIR BRAKET DESTEĞİ
- (AR) سادة دعامة علوية قابلة للتعديل للباب المنزلقي لإطار القطاع على شكل حرف „U“
- (CHN) U型框门上都可调节托臂托座
- (MAL) BANTUAN PENDAKAP BOLEH LARAS ATAS UNTUK PINTU GELONGSOR BINGKAI PROFIL „U“
- (H) FELSŐ ÁLLÍTHATÓ BEFOGÁS U-VEZETŐSÍNES TOLÓAJTÓHOZ
- (IL) לוללות הזזה U פחית תמיכה עליונה מתכווננת למסגרת מפרופיל
- (BG) ГОРНА РЕГУЛИРУЕМА ПОДДЪРЖАЩА СКОБА ЗА „U“-ПРОФИЛНА РАМКА ЗА ПЛЪЗГАЩА ВРАТА
- (KO) „U“자형 프로필 프레임 슬라이딩 도어용 상단 조절식 브라켓 지지대
- (SRB) GORNJI PODESIVI KONZONI NOSAČ ZA KLIZNA VRATA „U“ PROFILA

Art.	„U“ PROFILE	1pc			CODE
			pcs	kg	
AD 150	MCD 60	1,31	4	5,24	1700309

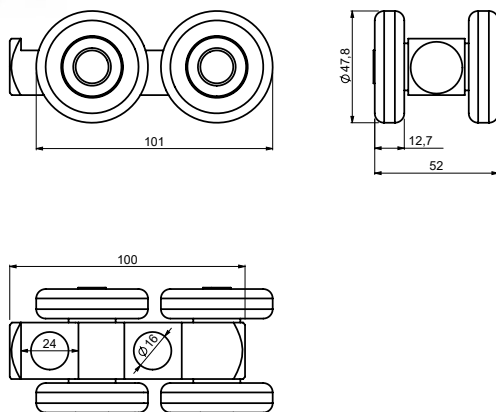

- (GB) FOUR WHEELED CARRIAGE FOR SLIDING DOORS
- (D) LAUFWAGEN MIT VIER LAUFRÄDERN FÜR FALT- UND SCHIEBETORE
- (F) CHARIOT QUATRE ROUES POUR PORTES COULISSANTES
- (E) CARRIL DE CUATRO RUEDAS PARA PUERTAS CORREDERAS
- (P) CORREDIÇA DE QUATRO ROLDANAS PARA PORTAS DESLIZANTES
- (I) CARRELLO A QUATTRO RUOTE PER PORTE SCORREVOLI
- (DK) FIREHJULET SLÆDE TIL SKYDEDØRE
- (NL) VIEROUDIG WIELENBLOK VOOR SCHUIFDEUREN
- (N) FIREHJULS GLIDESKINNE TIL SKYVEDØRER
- (S) FYRHJULAD VAGN FÖR SKJUTBARA DÖRRAR
- (FIN) NELIPYÖRÄINEN ALUSTA LIUKUOVIIN
- (PL) WÓZEK 4-ROLKOWY DO DRZWI PRZESUWNYCH
- (SK) VOZÍK ŠTVORKOLIEČKOVÝ LOŽISKOVÝ PRE POSUVNÚ ZÁVESNÚ BRÁNU
- (EE) NELJARATTALINE SUPORT LIUGUSTE JAOKS
- (LT) VEŽIMĖLIS SU KETURIAIS RATUKAIS STUMDOMOSIOMS DURIMS
- (LV) ČETRU RUĻĻU BLOKS BĪDĀMAJĀM DURVĪM

- (CZ) VOZÍK ČTYŘKOLOVÝ LOŽISKOVÝ PRO POSUVNÁ ZAVĚŠENÁ VRATA
- (RO) CĂRUCIOR PE PATRU ROȚI PENTRU UȘILE GLISANTE
- (HR) NOSAČ S ČETIRI KOTAČA ZA KLIZNA VRATA
- (RUS) ТЕЛЕЖКА ЧЕТЫРЕХКОЛЕСНАЯ ПОДШИПНИКОВАЯ ДЛЯ РАЗДВИЖНЫХ ПОДВЕСНЫХ ПРОМЫШЛЕННЫХ ВОРОТ
- (SLO) VOZIČEK S ŠTIRIMI KOLESI ZA DRSNÁ VRATA
- (TR) SÜRGÜLÜ KAPILAR İÇİN DÖRT TEKERLEKLİ TAŞIYICI
- (AR) عربة زباجية العجلات للأبواب المنزلقة "C"
- (CHN) 滑动门四轮滑架
- (MAL) PENYORONG EMPAT RODA UNTUK PINTU GELONGSOR
- (H) NÉGYGÖRGÖS FUTÓKOCSI TOLÓAJTÓKHOZ
- (IL) עגלה ארבעה גלגלים לדלת חזזה כבדה
- (BG) КОЛИЧКА С ЧЕТИРИ РОЛКИ ЗА ПЛЪЗГАЩИ ВРАТИ
- (KO) 슬라이딩 도어용 사중 휠 이송대
- (SRB) NOSAČ SA ČETIRI TOČKIČA ZA KLIZNA VRATA

Art.	GUIDE	CAPACITY	1pc		CODE	
			kg	kg	pcs	kg
SPEED C	STAGE SZ	480	0,9	10	9	1700144

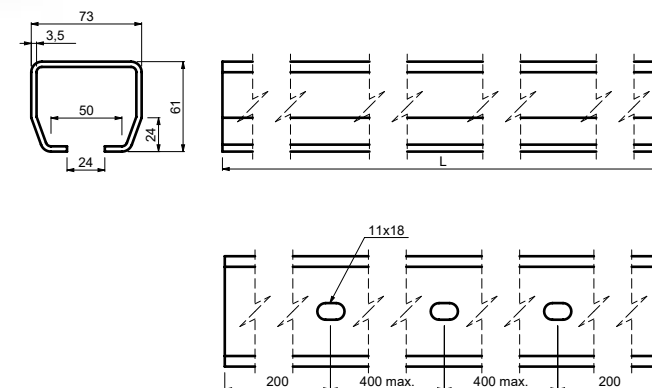
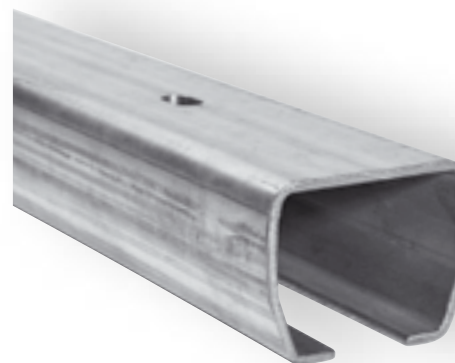

- (GB) „C“ PROFILE GUIDE FOR SLIDING DOORS
- (D) „C“ PROFIL FÜR FALT- UND SCHIEBETORE
- (F) GUIDE À PROFIL EN « C » POUR PORTES COULISSANTES
- (E) GUÍA CON PERFIL "C" PARA PUERTAS CORREDERAS
- (P) GUIA DE PERFIL EM "C" PARA PORTAS DESLIZANTES
- (I) GUIDA CON PROFILO A "C" PER PORTE SCORREVOLI
- (DK) "C" PROFILVANGE TIL SKYDEDØRE
- (NL) "C" PROFIEL GELEIDER VOOR SCHUIFDEUREN
- (N) "C"-PROFILSKINNE TIL SKYVEDØRER
- (S) "C" GEJDPROFIL FÖR SKJUTBARA DÖRRAR
- (FIN) "C"-PROFILLIHOJAIN LIUKUOVIIN
- (PL) SZYNA O PROFILU „C“ DO DRZWI PRZESUWNYCH
- (SK) NOSNÝ „C“ PROFIL PRE POSUVNÉ ZÁVESNÉ BRÁNY
- (EE) "C"-PROFILI JUHIK LIUGUSTE JAOKS
- (LT) „C“ FORMOS PROFILIUOTAS KREIPTUVAS STUMDOMOSIOMS DURIMS
- (LV) "C" VEIDA PROFILS BĪDĀMAJĀM DURVĪM

- (CZ) ŠÍNA „C“ PROFIL PRO POSUVNÁ ZAVĚŠENÁ VRATA
- (RO) GHIDAJ CU PROFIL „C“ PENTRU UȘILE GLISANTE
- (HR) VODILICA „C“ PROFILA ZA KLIZNA VRATA
- (RUS) НАПРАВЛЯЮЩИЙ РЕЛЬС / ПРОФИЛЬ «С» ДЛЯ РАЗДВИЖНЫХ ПОДВЕСНЫХ ПРОМЫШЛЕННЫХ ВОРОТ
- (SLO) "C" VODILO ZA DRSNÁ VRATA
- (TR) SÜRGÜLÜ KAPILAR İÇİN "C" PROFİL KIZAĞI
- (AR) لأبواب المنزلقة "C" دعامة نظلية جانبية
- (CHN) 滑动门"C"型导轨
- (MAL) PANDU PROFIL "C" UNTUK PINTU GELONGSOR
- (H) C-VEZETŐSÍN TOLÓAJTÓKHOZ
- (IL) מסילה לדלת חזזה כבדה
- (BG) "C"-ОБРАЗНА РЕЛСА ЗА ПЛЪЗГАЩИ ВРАТИ
- (KO) 슬라이딩 도어용 "C"자형 프로파일 가이드
- (SRB) VODICA „C“ PROFILA ZA KLIZNA VRATA

Art.	CARRIAGE	SURFACE FINISH	L/1pc	1pc	CODE		
			mm	kg	pcs	kg	
STAGE SZ 6	SPEED C	GALVANIZED	6000	33	24	792	1700003
STAGE SZ 5,6	SPEED C	GALVANIZED	5600	30,8	24	739,2	1700177
STAGE SZ 3	SPEED C	GALVANIZED	3000	16,5	24	396	1700168
STAGE SZ 2,8	SPEED C	GALVANIZED	2800	15,4	24	369,6	1720016
STAGE SZ 1	SPEED C	GALVANIZED	1000	5,5	24	132	1720018

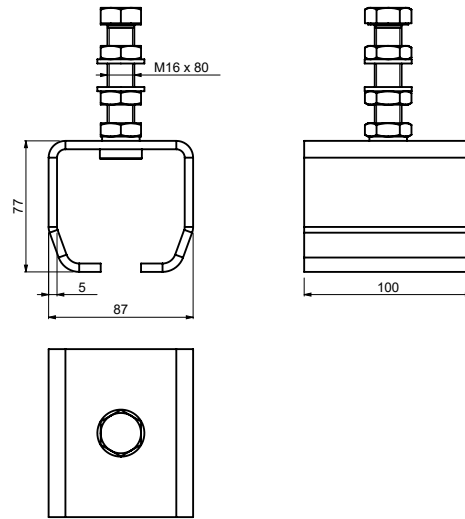

- (GB) ADJUSTABLE GUIDE SUPPORT
- (D) HALTERUNG FÜR „C“ PROFIL, REGULIERBAR
- (F) SUPPORT DE GUIDE RÉGLABLE
- (E) SOPORTE DE GUÍA AJUSTABLE
- (P) SUPORTE GUIA AJUSTÁVEL
- (I) SOSTEGNO PER GUIDA REGOLABILE
- (DK) INDSTILLELIG VANGEUNDERSTØTNING
- (NL) VERSTELBARE GELEIDERSTEUN
- (N) JUSTERBAR STØTTE TIL STYRESKINNE
- (S) JUSTERBART GEJDSTÖD
- (FIN) SÄÄDETTÄVÄ OHJAINUKI
- (PL) REGULOWANY UCHWYT SZYNY
- (SK) DRŽIAK NOSNÉHO „C“ PROFILU HORNÝ, REGULOVATELNÝ
- (EE) REGULEERITAV JUHTTUGI
- (LT) REGULIUOJAMA KREIPTUVO ATRAMA
- (LV) REGULĒJAMS VADOTNES BALSTS

- (CZ) DRŽÁK ŠÍNY „C“ PROFILU HORNÍ, REGULOVATELNÝ
- (RO) SUPORT GHIDAJ REGLABIL
- (HR) PRILAGODLJIV DRŽAČ VODILICE
- (RUS) КРОНШТЕЙН ДЛЯ НАПРАВЛЯЮЩЕГО РЕЛЬСА «С» ВЕРХНИЙ, РЕГУЛИРУЮЩИЙСЯ
- (SLO) NASTAVLJIVI PODPORNİK VODILA
- (TR) AYARLANABİLİR KIZAK DESTEĞİ
- (AR) الدعامة الدليلية القابلة للتعديل
- (CHN) 可调导轨支座
- (MAL) SOKONGAN PANDU BOLEH LARAS
- (H) ÁLLÍTHATÓ VEZETŐSÍN-RÖGZÍTÉS
- (IL) מתקן קרוי לתוספת מסילה כבדה
- (BG) РЕГУЛИРУЕМ ДЪРЖАЧ НА РЕЛСА
- (KO) 조절식 가이드 지지대
- (SRB) PODESIVI DRŽAČ VODICE

Art.	GUIDE	1pc			CODE
		kg	pcs	kg	
DC 70	STAGE SZ	1,19	8	9,52	1700146

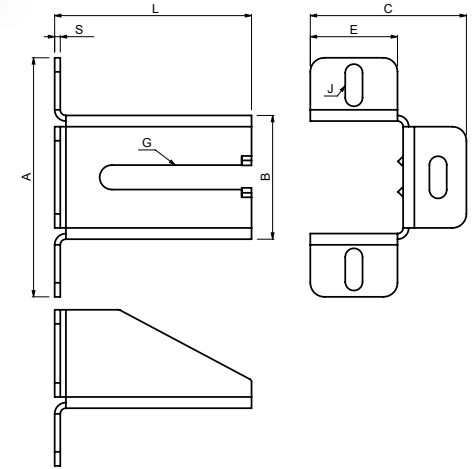
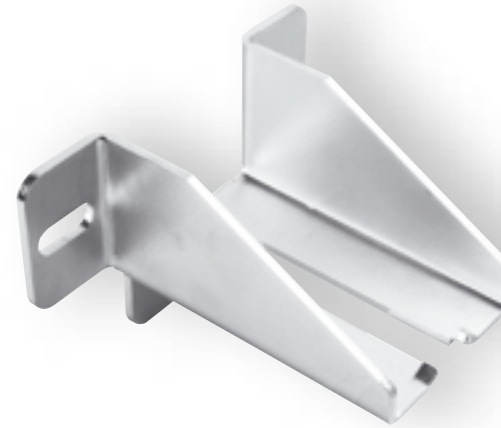

- (GB) ADJUSTABLE BRACKET FOR GUIDE SUPPORT
- (D) KONSOLE FÜR SCHIENENHALTERUNG
- (F) ÉTRIER RÉGLABLE POUR SUPPORT DE GUIDE
- (E) BASE AJUSTABLE PARA SOPORTE DE GUÍA
- (P) SUPORTE AJUSTÁVEL PARA SUPORTE GUIA
- (I) STAFFA REGOLABILE PER SOSTEGNO DELLA GUIDA
- (DK) INDSTILLELIGT BESLAG TIL VANGEUNDERSTØTNING
- (NL) VERSTELBARE BEUGEL VOOR GELEIDERSTEUN
- (N) JUSTERBAR BRAKETT FOR STYRESKINNE
- (S) JUSTERBAR KONSOL FÖR GEJDSTÖD
- (FIN) SÄÄDETTÄVÄ KANNATIN OHJAINUKKEEN
- (PL) REGULOWANY WSPORNIK DO UCHWYTU SZYNY
- (SK) KONZOLA PRE DRŽIAK NOSNÝCH „C“ PROFILOV
- (EE) REGULEERITAV KLAMBER JUHTTOE JAOKS
- (LT) REGULIUOJAMA KREIPTUVO ATRAMOS GEMBĖ
- (LV) REGULĒJAMS KRŌNŠTEINS VADOTNES BALSTAM

- (CZ) KONZOLA PRO DRŽÁK ŠÍNY „C“ PROFIL
- (RO) CONSOLĂ REGLABILĂ DE SUPORT PENTRU GHIDAJ
- (HR) PRILAGODLJIVA KONZOLA ZA DRŽAČ VODILICE
- (RUS) КРЕПЕЖНАЯ КОНСОЛЬ КРОНШТЕЙНА ДЛЯ НАПРАВЛЯЮЩЕГО РЕЛЬСА «С»
- (SLO) NASTAVLJIVI OPORNIK ZA PODPORNİK VODILA
- (TR) KIZAK DESTEĞİ İÇİN AYARLANABİLİR DİRSEK
- (AR) دعامة قنية للتعديل خاصة بالدعامة الدليلية
- (CHN) 导轨支轮可调壁式支座
- (MAL) PENDAKAP BOLEH LARAS UNTUK SOKONGAN PANDU
- (H) ÁLLÍTHATÓ KERET A VEZETŐSÍN RÖGZÍTÉSÉHEZ
- (IL) מתקן קרוי לתוספת מסילה כבדה
- (BG) РЕГУЛИРУЕМА СКОБА ЗА ДЪРЖАЧ НА РЕЛСА
- (KO) 가이드 지지대용 조절벽 브래킷
- (SRB) PODESIVA KONZOLA ZA DRŽAČ VODICE

Art.	L	A	B	C	E	G	J	S	SUPPORT	1pc			CODE
										kg	pcs	kg	
													mm
KHL 140	140	172	88	112	62	17x105	12x30	4	DC 70	0,94	8	7,52	1700147
KHL 180	180	172	88	112	62	17x142	12x30	4	DC 70	1,05	6	6,3	1700164

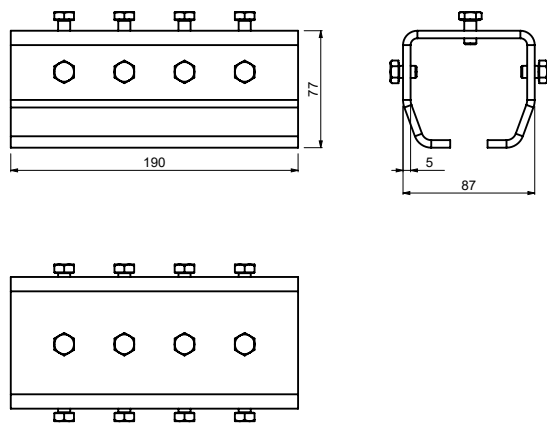

- (GB) „C” PROFILE GUIDE JOINT BRACKET
- (D) „C”-PROFILFÜHRUNG, GELENKHALTERUNG
- (F) SUPPORT DE JOINT DE GUIDE DE PROFIL EN „C”
- (E) SOPORTE DE UNIÓN DE GUÍA DE PERFIL EN „C”
- (P) GUIA DE PERFIL „C” GUIA COMUM
- (I) STAFFA DI ACCOPIAMENTO GUIDA CON PROFILO A „C”
- (DK) BESLAG TIL „C” PROFILVANGFORBINDELSE
- (NL) „C” PROFIELGELEIDER VERBINDINGSSTUK BEVESTIGINGSBEUGEL
- (N) „C” PROFILSTYRINGSBRACKET
- (S) „C” GEJDPROFIL FÖR KONSOL
- (FIN) „C”-PROFILISEN OHJAIMEN LIITOKSEN KANNATIN
- (PL) WSPORNIK ŁĄCZĄCY DO SZYN O PROFILU „C”
- (SK) PRIPOJOVACÍ DRŽIAK PROFILU VODIACEJ LIŠTY V TVARE „C”
- (EE) „C”-PROFIL JUHIKU ÜHENDUSE KLAMBER
- (LT) „C” FORMOS PROFILIUOTO KREIPTUVO JUNGIAMASIS LAIKIKLIS
- (LV) „C” VEIDA PROFILA SAVIENOTĀJBALSTENIS

- (CZ) SPOJKA FIXAČNÍ PRO „C” PROFIL
- (RO) REAZEM ÎN FORMĂ DE „C” PENTRU PROFILUL DE GHIDAJ
- (HR) ZGLOBNI NOSAČ „C” PROFILNE VODILICE
- (RUS) ВТУЛОЧНЫЙ КРОНШТЕЙН ДЛЯ НАПРАВЛЯЮЩИХ РЕЛЬСОВ ПРОФИЛЯ «С»
- (SLO) PRITRDILNI NOSILEC Z VODILOM S„C” PROFILOM
- (TR) „C” PROFIL YATAĞI BAĞLANTI BRAKETİ
- (AR) دعامة مفصل موجه قطاع على شكل حرف "C"
- (CHN) C型导向关节托臂
- (MAL) PENDAKAP TERCANTUM PANDU PROFIL „C”
- (H) C-VEZETŐSÍN ÖSSZEKÖTŐELEM
- (IL) פרופיל מוביל צורת C עם סגר פח
- (BG) СВЪРЗАЩА СКОБА ЗА „C”-ОБРАЗНА РЕЛСА
- (KO) “C”자형 프로필 가이드 조인트 브래킷
- (SRB) NOSAČ SPOJNICE ZA VOĐICU „C” PROFILA

Art.	GUIDE	1pc		CODE
		kg	pcs	
DF 190	STAGE SZ	1,94	2	1700304

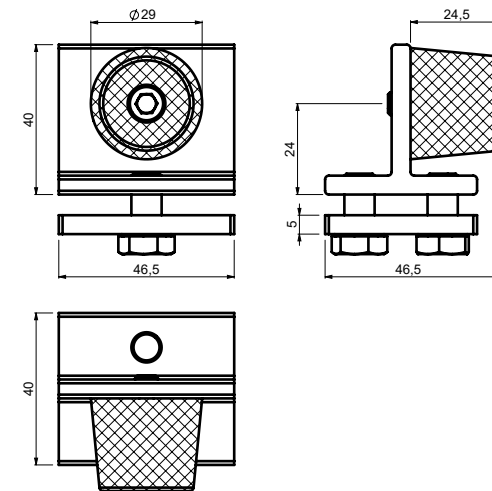
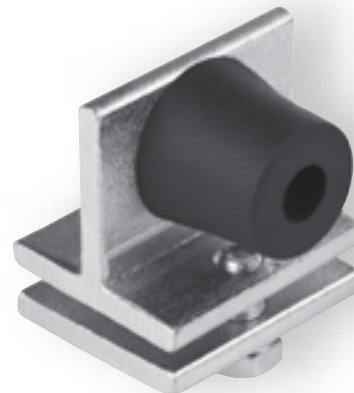

- (GB) INTERNAL GUIDE END STOP
- (D) INNENANSCHLAG FÜR „C” PROFIL
- (F) BUTÉE INTERNE POUR GUIDE
- (E) TOPE FINAL DE GUÍA INTERNA
- (P) BATENTE GUIA INTERNA
- (I) FERMO DI FINE CORSA DELLA GUIDA INTERNA
- (DK) INTERN STYREENDESTOP
- (NL) INTERNE GELEIDER EINDSTOP
- (N) ENDESTOPPER TIL INNVEDIG SKINNE
- (S) INTERNT GEJD ÅNDSTOPP
- (FIN) SISÄINEN OHJAIMEN PÄÄN PYSÄYTIN
- (PL) WEWNĘTRZNY ODBOJNIK SZYNY
- (SK) DORAZ VNÚTORNY PRE NOSNÝ „C” PROFIL
- (EE) SISEJUHIKU OTSALÕPP
- (LT) VIDINIO KREIPTUVO GALINIS RIBOKLIS
- (LV) IEKŠĒJĀIS VADOTNES GALA AIZTURIS

- (CZ) DORAZ VNITŘNÍ PRO ŠINU „C” PROFIL
- (RO) GHIDAJ OPRITOR CURSĂ INTERN
- (HR) UNUTARNJI GRANIČNIK VODILICE
- (RUS) ВНУТРЕННИЙ ОГРАНИЧИТЕЛЬ НАПРАВЛЯЮЩЕГО РЕЛЬСА «С»
- (SLO) ZAUSTAVLJALNIK NOTRANJEGA VODILA
- (TR) DAHİLİ KIZAK UÇ TESPİT PARÇASI
- (AR) ممانع طرفي داخلي
- (CHN) 内导轨终点挡块
- (MAL) PENYENDAL Hujung PANDU DALAM
- (H) VEZETŐSÍN BELSŐ ÚTKÖZŐ
- (IL) מעצור פנימי למסילה עליונה
- (BG) ВЪТРЕШЕН СТОПЕР ЗА РЕЛСА
- (KO) 내부 가이드 종단 장치대
- (SRB) UNUTRAŠNJI GRANIČNIK VOĐICE

Art.	GUIDE	1pc		CODE
		kg	pcs	
FINISH S	STAGE SZ	0,24	20	1700008

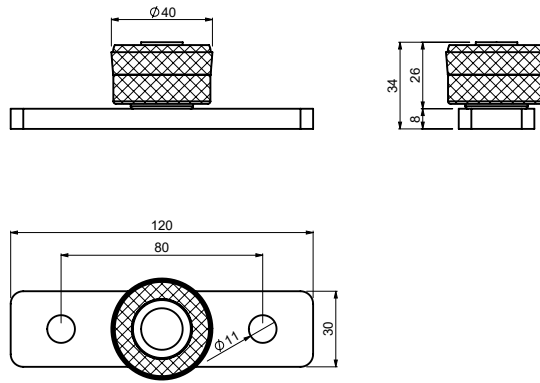
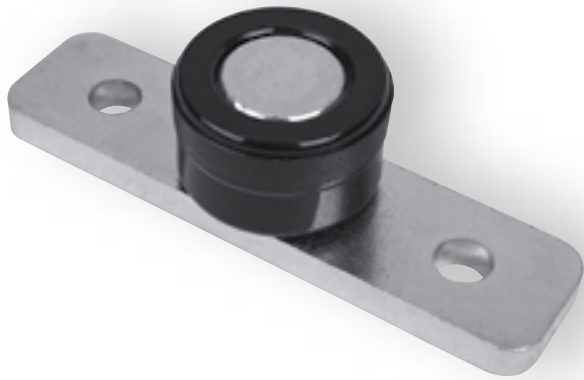

- (GB) EMBEDDED LOWER GUIDE ROLLER WITH PLATE FOR SLIDING DOORS AND SHUTTERS  
 (D) UNTERE FÜHRUNGSROLLE FÜR TÜREN UND TÖRE  
 (F) GUIDE À ROULEAU INFÉRIEUR INTÉGRÉ AVEC PLATINE POUR PORTES COULISSANTES ET VOLETS  
 (E) RODILLO DE GUÍA INFERIOR INTEGRADA CON PLATO PARA POSTIGOS Y PUERTAS CORREDERAS  
 (P) ROLETE GUIA INFERIOR EMBUTIDO COM PLACA PARA PORTAS E PERSIANAS DESLIZANTES  
 (I) RULLO PER GUIDA INFERIORE INCORPORATA, CON PIASTRA, PER PORTE E SERRANDE SCORREVOLI  
 (DK) INDSTØBT NEDERSTE STYREVALSE MED PLADE TIL SKYDEPORTE OG LUKKERE  
 (NL) VASTE GELEIDINGSROL ONDERKANT MET GRONDPLAAT VOOR SCHUIFDEUREN EN LUIKEN  
 (N) INNEBYGD LAVERE STYRERULLE MED PLATE FOR SKYVEDØRER OG SKODDER  
 (S) INBYGGD UNDER RULLGEJD MED PLATTA FÖR SKJUTBARA DÖRRAR OCH FÖNSTERLUCKOR  
 (FIN) KOTILOITU ALOAHOJAUSRULLA LEVYLLÄ LUUKUOVIN JA -LUUKKUIHIN  
 (PL) WBUDOWANA DOLNA ROLKA PROWADZĄCA Z PŁYTKĄ DO DRZWI PRZESUWNYCH I ŻALUZJI  
 (SK) KLADKA SPODNÁ VODIACA S PLATŇOU PRE DVERE, BRÁNY A SVETLOLAMY  
 (EE) SISSEBURUTUD ALUMINE JUHTRULLIK PLAADIGA LIUGUSTE JA -LUUKIDE JAOKS  
 (LT) ĮLEISTASIS APATINIO KREIPTUVO RITINĖLIS SU PLOKŠTELE STUMDOMOSIOMS DURIMS IR LANGINĖMS  
 (LV) IEBŪVĒTS APAKŠĒJAIS VADRULLĪTIS AR PLĀKSNĪ BĪDĀMAJĀM DURVĪM UN AIZBĪDNIEM

- (CZ) KLADKA SPODNÍ VODÍČÍ S PLOTNOU PRO DVEŘE, VRATA A SVĚTLŮLAMY  
 (RO) ROLĂ INFERIOARĂ ÎNCĂSTRATĂ CU PLACĂ PENTRU UȘILE GLISANTE ȘI ÎNCHIZĂTOARE  
 (HR) UKLOPLJENA DONJA ROLICA S PLOČOM, ZA KLIZNA VRATA I ŽALUZINE  
 (RUS) РОЛИК НИЖНИЙ НАПРАВЛЯЮЩИЙ С ПЛАСТИНОЙ ДЛЯ ДВЕРЕЙ, ВОРОТ И ЖАЛЮЗЕЙ  
 (SLO) UTOPNO SPODNJE VODILNO KOLO S PLOŠČO ZA DRŠNA VRATA IN ŽALUZIE  
 (TR) SÜRGÜLÜ KAPILAR VE OPTÜRATÖRLER İÇİN PLAKALI GÖMÜLÜ ALT KIZAK RULMANI  
 (AR) بكره دليلية منخفضة مدمجة مع لوحة الألواب والرفقات المنزلقة  
 (CHN) 滑动门与百叶窗嵌入式带导板下导轮  
 (MAL) PENGGULING PANDU BAWAH TERBENAM DENGAN PLAT UNTUK PINTU DAN PENUTUP GELONGSOR  
 (H) BEÁGYAZOTT ALSÓ VEZETŐGÖRGŐ LEMEZZEL, TOLÓAJTÓKHOZ ÉS ZSILÍPEKHEZ  
 (IL) גלגל מוביל מתחת ללוח המגילות ולמסגרות הדלתות  
 (BG) ВЛОЖЕНА ДОЛНА РОЛКА ВОДНА С ПЛАНКА ЗА ПЛЪЗГАЩИ ВРАТИ И КАПАЦИ  
 (KO) 슬라이딩 도어 및 셔터를 내장식 하단 가이드 플러 및 플레이트  
 (SRB) UGRADEN DONJI VALJAK SA PLOČOM ZA KLIZNA VRATA I ŽALUZINE KAPIJE

Art.	1pc				CODE
	kg	pcs	kg		
RS 25	0,29	20	5,8		1700159

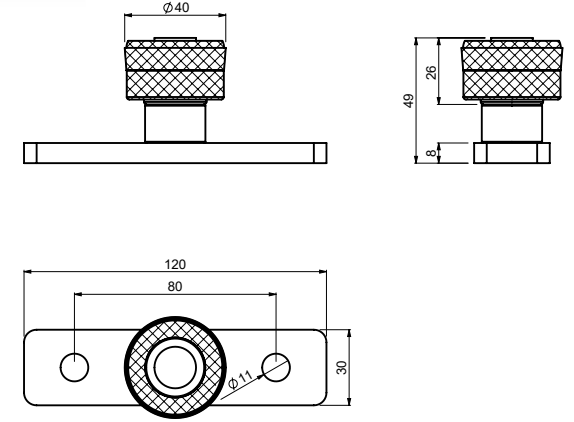

- (GB) EMBEDDED LOWER GUIDE ROLLER WITH PLATE FOR SLIDING DOORS AND SHUTTERS  
 (D) UNTERE FÜHRUNGSROLLE FÜR TÜREN UND TÖRE  
 (F) GUIDE À ROULEAU INFÉRIEUR INTÉGRÉ AVEC PLATINE POUR PORTES COULISSANTES ET VOLETS  
 (E) RODILLO DE GUÍA INFERIOR INTEGRADA CON PLATO PARA POSTIGOS Y PUERTAS CORREDERAS  
 (P) ROLETE GUIA INFERIOR EMBUTIDO COM PLACA PARA PORTAS E PERSIANAS DESLIZANTES  
 (I) RULLO PER GUIDA INFERIORE INCORPORATA, CON PIASTRA, PER PORTE E SERRANDE SCORREVOLI  
 (DK) INDSTØBT NEDERSTE STYREVALSE MED PLADE TIL SKYDEPORTE OG LUKKERE  
 (NL) VASTE GELEIDINGSROL ONDERKANT MET GRONDPLAAT VOOR SCHUIFDEUREN EN LUIKEN  
 (N) INNEBYGD LAVERE STYRERULLE MED PLATE FOR SKYVEDØRER OG SKODDER  
 (S) INBYGGD UNDER RULLGEJD MED PLATTA FÖR SKJUTBARA DÖRRAR OCH FÖNSTERLUCKOR  
 (FIN) KOTILOITU ALOAHOJAUSRULLA LEVYLLÄ LUUKUOVIN JA -LUUKKUIHIN  
 (PL) WBUDOWANA DOLNA ROLKA PROWADZĄCA Z PŁYTKĄ DO DRZWI PRZESUWNYCH I ŻALUZJI  
 (SK) KLADKA SPODNÁ VODIACA S PLATŇOU PRE DVERE, BRÁNY A SVETLOLAMY  
 (EE) SISSEBURUTUD ALUMINE JUHTRULLIK PLAADIGA LIUGUSTE JA -LUUKIDE JAOKS  
 (LT) ĮLEISTASIS APATINIO KREIPTUVO RITINĖLIS SU PLOKŠTELE STUMDOMOSIOMS DURIMS IR LANGINĖMS  
 (LV) IEBŪVĒTS APAKŠĒJAIS VADRULLĪTIS AR PLĀKSNĪ BĪDĀMAJĀM DURVĪM UN AIZBĪDNIEM

- (CZ) KLADKA SPODNÍ VODÍČÍ S PLOTNOU PRO DVEŘE, VRATA A SVĚTLŮLAMY  
 (RO) ROLĂ INFERIOARĂ ÎNCĂSTRATĂ CU PLACĂ PENTRU UȘILE GLISANTE ȘI ÎNCHIZĂTOARE  
 (HR) UKLOPLJENA DONJA ROLICA S PLOČOM, ZA KLIZNA VRATA I ŽALUZINE  
 (RUS) РОЛИК НИЖНИЙ НАПРАВЛЯЮЩИЙ С ПЛАСТИНОЙ ДЛЯ ДВЕРЕЙ, ВОРОТ И ЖАЛЮЗЕЙ  
 (SLO) UTOPNO SPODNJE VODILNO KOLO S PLOŠČO ZA DRŠNA VRATA IN ŽALUZIE  
 (TR) SÜRGÜLÜ KAPILAR VE OPTÜRATÖRLER İÇİN PLAKALI GÖMÜLÜ ALT KIZAK RULMANI  
 (AR) بكره دليلية منخفضة مدمجة مع لوحة الألواب والرفقات المنزلقة  
 (CHN) 滑动门与百叶窗嵌入式带导板下导轮  
 (MAL) PENGGULING PANDU BAWAH TERBENAM DENGAN PLAT UNTUK PINTU DAN PENUTUP GELONGSOR  
 (H) BEÁGYAZOTT ALSÓ VEZETŐGÖRGŐ LEMEZZEL, TOLÓAJTÓKHOZ ÉS ZSILÍPEKHEZ  
 (IL) גלגל מוביל מתחת ללוח המגילות ולמסגרות הדלתות  
 (BG) ВЛОЖЕНА ДОЛНА РОЛКА ВОДНА С ПЛАНКА ЗА ПЛЪЗГАЩИ ВРАТИ И КАПАЦИ  
 (KO) 슬라이딩 도어 및 셔터를 내장식 하단 가이드 플러 및 플레이트  
 (SRB) UGRADEN DONJI VALJAK SA PLOČOM ZA KLIZNA VRATA I ŽALUZINE KAPIJE

Art.	1pc				CODE
	kg	pcs	kg		
RS 40	0,34	20	6,8		1700160

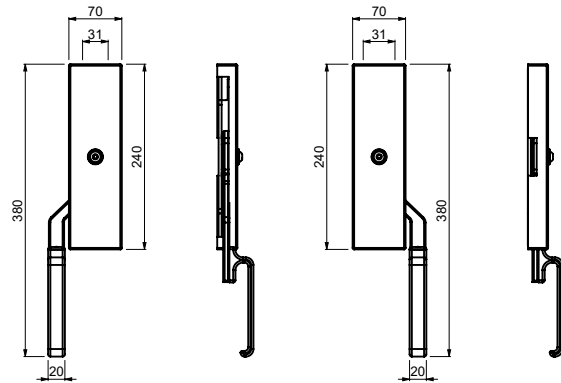

KL 70 L

KL 70 R



- (GB) VERTICAL LOCK FOR SLIDING DOORS
- (D) TRIEBRIEGEL
- (F) SERRURE VERTICALE POUR PORTES COULISSANTES
- (E) BLOQUEO VERTICAL PARA PUERTAS CORREDERAS
- (P) TRAVA VERTICAL PARA PORTAS DESLIZANTES
- (I) SERRATURA VERTICALE PER PORTE SCORREVOLI
- (DK) VERTIKAL LÅS TIL SKYDEDØRE
- (NL) VERTICAAL SLOT VOOR SCHUIFDEUREN
- (N) VERTIKAL LÅS FOR SKYVEDØRER
- (S) VERTIKALT LÅS FÖR SKJUTBARA DÖRRAR
- (FIN) PYSTYSUORA LUKKO LIUKUOVIIN
- (PL) ZAMEK PIONOWY DO DRZWI PRZESUWNYCH
- (SK) KLUČKA S VERTIKÁLNYM POHYBOM PRE POSUVNÉ ZÁVESNÉ BRÁNY
- (EE) VERTIKAALNE LUKK LIUGUSTE JAOKS
- (LT) VERTIKALUS STUMDOMŲ DURŲ UŽRAKTAS
- (LV) VERTIKĀLS FIKSATORS BĪDĀMAJĀM DURVĪM

- (CZ) KLIKA S VERTIKÁLNÍM POHYBEM PRO POSUVNÁ ZAVĚŠENÁ VRATA
- (RO) BLOCAJ VERTICAL PENTRU UȘILE GLISANTE
- (HR) VERTIKALNA BRAVA ZA KLIZNA VRATA
- (RUS) ЗАТВОР ВЕРТИКАЛЬНЫЙ ДЛЯ РАЗДВИЖНЫХ ПОДВЕСНЫХ ПРОМЫШЛЕННЫХ ВОРОТ
- (SLO) VERTIKALNA KLJUČAVNICA ZA DRSNÁ VRATA
- (TR) SÜRGÜLÜ KAPILAR İÇİN DİKEY KİLİT
- (AR) القفل العمودي للمنخفض للأبواب المنزلقة
- (CHN) 滑动门垂直锁
- (MAL) KUNCI MENEGAK UNTUK PINTU GELONGSOR
- (H) FÜGGŐLEGES ZÁR TOLÓAJTÓKHOZ
- (IL) ברית אנכי לדלת הזזה כבדה
- (BG) ВЕРТИКАЛНА КЛЮЧАЛКА ЗА ПЛЪЗГАЩИ ВРАТИ
- (KO) 슬라이딩 도어를 수직 잠금장치
- (SRB) VERTIKALNA BRAVA ZA KLIZNA VRATA

Art.	ROD	1pc			CODE
		kg	pcs	kg	
KL 70 L	TL 30/TL 40	1,44	5	7,2	1700148
KL 70 R	TL 30/TL 40	1,44	5	7,2	1700149

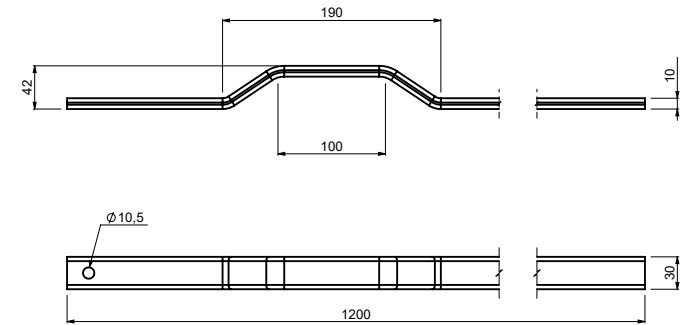
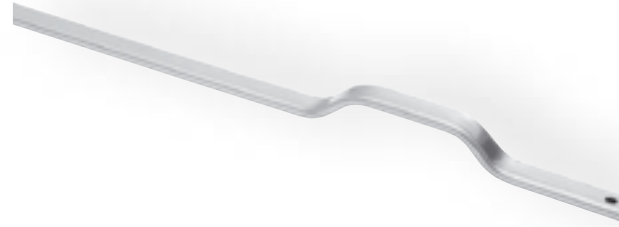

- (GB) LOWER VERTICAL LOCKING ROD FOR SLIDING DOORS
- (D) STANGE FÜR TRIEBRIEGEL
- (F) TIGE DE FERMETURE VERTICALE INFÉRIEURE POUR PORTES COULISSANTES
- (E) VARILLA DE BLOQUEO VERTICAL INFERIOR PARA PUERTAS CORREDERAS
- (I) ASTA DI BLOCCAGGIO VERTICALE INFERIORE, PER PORTE SCORREVOLI
- (DK) NEDERSTE VERTIKALE LÅSESTANG TIL SKYDEDØRE
- (NL) ONDERSTE VERTICALE SLUITSTANG VOOR SCHUIFDEUREN
- (N) NEDRE VERTIKALE LÅSESTANG FOR SKYVEDØRER
- (S) UNDRE VERTIKAL LÅSSTÅNG FÖR SKJUTBARA DÖRRAR
- (FIN) ALEMPI PYSTYSUORA LUKITUSVARSI LIUKUOVIIN
- (PL) DOLNY PIONOWY PRĘT BLOKUJĄCY DO DRZWI PRZESUWNYCH
- (SK) TYČ ZATVÁRACIA SPODNÁ PRE KLUČKU S VERTIKÁLNYM POHYBOM
- (EE) ALUMINE VERTIKAALNE LUKUSTUSVARRAS LIUGUSTE JAOKS
- (LT) APATINIS VERTIKALUS STUMDOMŲ DURŲ UŽRAKTO STRYPAS
- (LV) VERTIKĀLS APAKŠĒJAIS FIKSĒŠANAS STIENIS BĪDĀMAJĀM DURVĪM

- (CZ) TYČ ZAVÍRACÍ SPODNÍ PRO KLIKA S VERTIKÁLNÍM POHYBEM
- (RO) TIJĂ BLOCAJ VERTICALĂ INFERIOARĂ PENTRU UȘILE GLISANTE
- (HR) DONJA ŠIPKA VERTIKALNE BRAVE ZA KLIZNA VRATA
- (RUS) НИЖНЯЯ ЗАКРЫВАЮЩАЯ РЕЙКА ДЛЯ ВЕРТИКАЛЬНОГО ЗАТВОРА
- (SLO) SPODNJI VERTIKALNI ZAPORNI ZATIČ KLJUČAVNICE ZA DRSNÁ VRATA
- (TR) SÜRGÜLÜ KAPILAR İÇİN ALT DİKEY KİLİTLEME ÇUBUĞU
- (AR) قضيب القفل العمودي المنخفض للأبواب المنزلقة
- (CHN) 滑动门下垂直锁杆
- (MAL) ROD MENGUNCI TEGAK BAWAH UNTUK PINTU GELONGSOR
- (H) ALSÓ FÜGGŐLEGES ZÁR-RÚD TOLÓAJTÓKHOZ
- (IL) מוט ברית תחתון
- (BG) ДОПЕН ЛОСТ ЗА ВЕРТИКАЛНА КЛЮЧАЛКА ЗА ПЛЪЗГАЩИ ВРАТИ
- (KO) 슬라이딩 도어를 하단 수직 잠금대
- (SRB) DONJA ŠIPKA VERTIKALNE BRAVE ZA KLIZNA VRATA

Art.	LOCK	1pc			CODE
		kg	pc	kg	
TL 30	KL 70 L/R	0,98	1	0,98	1700150

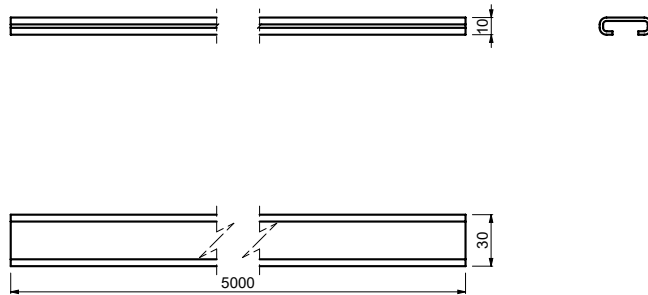

- (GB) UPPER VERTICAL LOCKING ROD FOR SLIDING DOORS
- (D) UNTERE SCHLIESSSTANGE FÜR TRIEBRIEGEL
- (F) TIGE DE FERMETURE VERTICALE SUPÉRIEURE POUR PORTES COULISSANTES
- (E) VARILLA DE BLOQUEO VERTICAL SUPERIOR PARA PUERTAS CORREDERAS
- (P) HASTE DE TRAVAMENTO VERTICAL SUPERIOR PARA PORTAS DESLIZANTES
- (I) ASTA DI BLOCCAGGIO VERTICALE SUPERIORE, PER PORTE SCORREVOLI
- (DK) ØVERSTE VERTIKALE LÅSESTANG TIL SKYDEDØRE
- (NL) BOVENSTE VERTICALE SLUITSTANG VOOR SCHUIFDEUREN
- (N) ØVRE VERTIKALE LÅSESTANG FOR SKYVEDØRER
- (S) ØVRE VERTIKAL LÅSSTÅNG FÖR SKJUTBARA DÖRRAR
- (FIN) YLEMPI PYSTYSUORA LUKITUSVARSI LIUKUOVIIN
- (PL) GÓRNY PIONOWY PRĘT BLOKUJĄCY DO DRZWI PRZESUWNYCH
- (SK) TYČ ZATVÁRACIA HORNÁ PRE KLUČKU S VERTIKÁLNYM POHYBOM
- (EE) ÜLEMINE VERTIKAALNE LUKUSTUSVARRAS LIUGUSTE JAOKS
- (LT) VIRŠUTINIS VERTIKALUS STUMDOMŲ DURŲ UŽRAKTO STRYPAS
- (LV) VERTIKĀLS AUGŠĒJĀIS FIKSĒŠANAS STIENIS BĪDĀMAJĀM DURVĪM

- (CZ) TYČ ZAVÍRACÍ HORNÍ PRO KLIKU S VERTIKÁLNÍM POHYBEM
- (RO) TIJĂ BLOCĂJ VERTICALĂ SUPERIOARĂ PENTRU UȘILE GLISANTE
- (HR) GORNJA ŠIPKA VERTIKALNE BRAVE ZA KLIZNA VRATA
- (RUS) ВЕРХНЯЯ ЗАКРЫВАЮЩАЯ РЕЙКА ДЛЯ ВЕРТИКАЛЬНОГО ЗАТВОРА
- (SLO) ZGORNJI VERTIKALNI ZAPORNI ZATIČ KLJUČAVNICE ZA DRSNNA VRATA
- (TR) SÜRGÜLÜ KAPILAR İÇİN ÜST DIKEY KİLİTLEME ÇUBUĞU
- (AR) قضيب القفل العمودي للأبواب المنزلقة
- (CHN) 滑动门上垂直锁杆
- (MAL) ROD MENGUNCI TEGAK ATAS UNTUK PINTU GELONGSOR
- (H) FELSŐ FÜGGŐLEGES ZÁR-RÚD TOLÓAJTÓKHOZ
- (IL) מוט ברזל עליון
- (BG) ГОРЕН ЛОСТ ЗА ВЕРТИКАЛНА КЛЮЧАЛКА ЗА ПЛЪЗГАЩИ ВРАТИ
- (KO) 슬라이딩 도어를 상단 수직 잠금대
- (SRB) GORNJA ŠIPKA VERTIKALNE BRAVE ZA KLIZNA VRATA

Art.	LOCK	1pc			CODE
		kg	pc	kg	
TL 40	KL 70 L/R	4,1	1	4,1	1700151

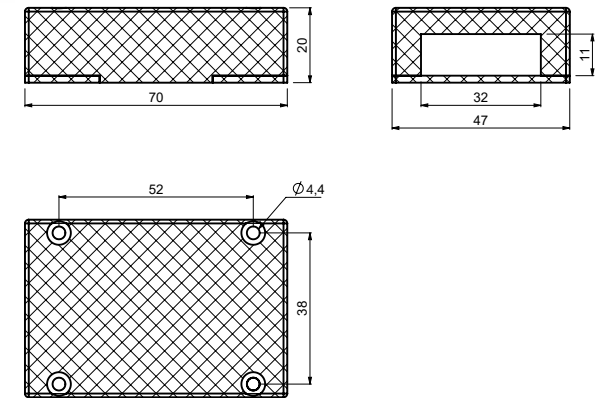
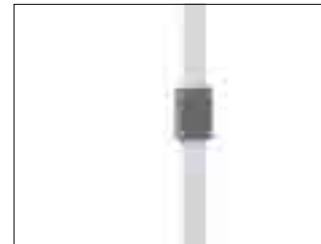
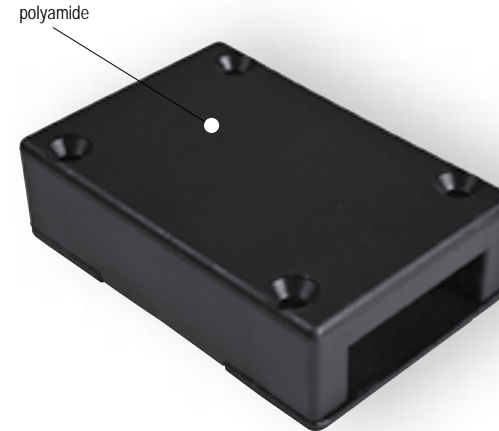

- (GB) GUIDE FOR UPPER AND LOWER VERTICAL LOCKING ROD ET INFÉRIEURE
- (D) FÜHRUNG FÜR FÜHRUNGSSTANGE
- (F) GUIDE POUR TIGE DE FERMETURE VERTICALE SUPÉRIEURE ET INFÉRIEURE
- (E) GUÍA PARA VARILLA DE BLOQUEO VERTICAL SUPERIOR E INFERIOR
- (P) GUIA PARA HASTE DE TRAVA VERTICAL SUPERIOR E INFERIOR
- (I) GUIDA PER ASTA DI BLOCCAGGIO VERTICALE SUPERIORE E INFERIORE
- (DK) VANGE TIL ØVERSTE OG NEDERSTE VERTIKALE LÅSESTANG
- (NL) GELEIDER VOOR BOVENSTE EN ONDERSTE VERTICALE SLUITSTANG
- (N) STYRESKINNE FOR ØVRE OG NEDRE VERTIKALE LÅSESTANG
- (S) GEJD FÖR ØVRE OCH UNDRER VERTIKAL LÅSSTÅNG
- (FIN) OHJAIN YLEMPÄÄN JA ALEMPÄÄN PYSTYSUORAAN LUKITUSVARTEEN
- (PL) PROWADNICA GÓRNEGO I DOLNEGO PIONOWEGO PRĘTA BLOKUJĄCEGO
- (SK) VODÍTKO PRE TYČ SPODNÉ A HORNÉ
- (EE) JUHIK ÜLEMISE- JA ALUMISE VERTIKAALSE LUKUSTUSVARDA JAOKS
- (LT) VIRŠUTINIO IR APATINIO VERTIKALUS UŽRAKTO STRYPŲ KREIPTUVAS
- (LV) VADOTNE VERTIKĀLAM AUGŠĒJĀM UN APAKŠĒJĀM FIKSĒŠANAS STIENĪM

- (CZ) VODÍTKO PRO TYČ SPODNÍ A HORNÍ
- (RO) GHIDAJ PENTRU TIJA DE BLOCARE VERTICALĂ INFERIOARĂ ȘI SUPERIOARĂ
- (HR) VODILICA ZA GORNJU I DONJU ŠIPKU VERTIKALNE BRAVE
- (RUS) НАПРАВЛЯЮЩИЙ КРОНШТЕЙН ДЛЯ НИЖНЕЙ И ВЕРХНЕЙ ВЕРТИКАЛЬНОЙ ЗАКРЫВАЮЩЕЙ РЕЙКИ
- (SLO) VODILO ZA ZGORNJI IN SPODNJI ZAPORNI ZATIČ VERTIKALNE KLJUČAVNICE
- (TR) ÜST VE ALT DIKEY KİLİTLEME ÇUBUĞU İÇİN KIZAK
- (AR) دليل قضيب القفل العمودي والمخفض
- (CHN) 上下垂直锁杆导轨
- (MAL) PANDU UNTUK ROD MENGUNCI TEGAK ATAS DAN BAWAH
- (H) VEZETŐELEM A FELSŐ ÉS AZ ALSÓ FÜGGŐLEGES ZÁR-RÚDHOZ
- (IL) מוביל לברזל עליון ותחתון
- (BG) ВОДАЧ ЗА ГОРЕН И ДОЛЕН ЛОСТ ЗА ВЕРТИКАЛНА КЛЮЧАЛКА
- (KO) 상단 및 하단 수직 잠금대용 가이드
- (SRB) VODICA ZA GORNJU I DONJU ŠIPKU VERTIKALNE BRAVE

Art.	ROD	1pc			CODE
		kg	pcs	kg	
TL 70	TL 30/TL 40	0,04	4	0,16	1700166



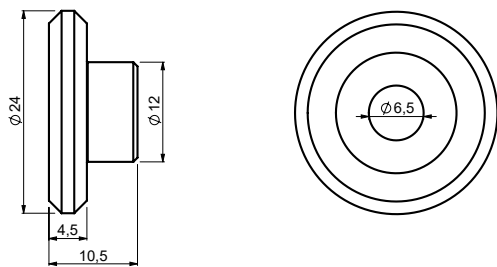

- (GB) GUIDE FOR UPPER AND LOWER VERTICAL LOCKING ROD
- (D) FÜHRUNG FÜR FÜHRUNGSSTANGE
- (F) GUIDE POUR TIGE DE FERMETURE VERTICALE SUPÉRIEURE ET INFÉRIEURE
- (E) GUÍA PARA VARILLA DE BLOQUEO VERTICAL SUPERIOR E INFERIOR
- (P) GUIA PARA HASTE DE TRAVA VERTICAL SUPERIOR E INFERIOR
- (I) GUIDA PER ASTA DI BLOCCAGGIO VERTICALE SUPERIORE E INFERIORE
- (DK) VANGE TIL ØVERSTE OG NEDERSTE VERTIKALE LÅSESTANG
- (NL) GELEIDER VOOR BOVENSTE EN ONDERSTE VERTICALE SLUITSTANG
- (N) STYRESKINNE FOR ØVRE OG NEDRE VERTIKALE LÅSESTANG
- (S) GEJD FÖR ØVRE OCH NEDRE VERTIKAL LÅSSTÅNG
- (FIN) OHJAIN YLEMPÄÄN JA ALEMPÄÄN PYSTYSUORAAN LUKITUSVARTEEN
- (PL) PROWADNICA GÓRNEGO I DOLNEGO PIONOWEGO PRĘTA BLOKUJĄCEGO
- (SK) VODÍTKO PRE TYČ SPODNÉ A HORNÉ
- (EE) JUHIK ÜLEMISE- JA ALUMISE VERTIKAALSE LUKUSTUSVARDA JAOKS
- (LT) VIRŠUTINIO IR APATINIO VERTIKALIAUS UŽRAKTO STRYPO KREIPTUVAS
- (LV) VADOTNE VERTIKĀLAM AUGŠĒJAM UN APAKŠĒJAM FIKSĒŠANAS STIENIM

- (CZ) VODÍTKO PRO TYČ SPODNÍ A HORNÍ
- (RO) GHIDAJ PENTRU TIJA DE BLOCARE VERTICALĂ INFERIOARĂ ȘI SUPERIOARĂ
- (HR) VODILICA ZA GORNJU I DONJU ŠIPKU VERTIKALNE BRAVE
- (RUS) НАПРАВЛЯЮЩИЙ КРОНШТЕЙН ДЛЯ НИЖНЕЙ И ВЕРХНЕЙ ВЕРТИКАЛЬНОЙ ЗАКРЫВАЮЩЕЙ РЕЙКИ
- (SLO) VODILO ZA ZGORNJI IN SPODNJI ZAPORNI ZATIČ VERTIKALNE KLJUČAVNICE
- (TR) ÜST VE ALT DIKEY KİLITLEME ÇUBUĞU İÇİN KIZAK
- (AR) دليل قضيب القفل العمودي العلوي والمنخفض
- (CHN) 上下垂直锁杆导轨
- (MAL) PANDU UNTUK ROD MENGUNCI TEGAK ATAS DAN BAWAH
- (H) VEZETŐELEM A FELSŐ ÉS AZ ALSÓ FÜGGŐLEGES ZÁR-RÚDHOZ
- (IL) מנביל לבריה עליון ותחתון
- (BG) ВОДАЧ ЗА ГОРЕН И ДОЛЕН ЛОСТ ЗА ВЕРТИКАЛНА КЛЮЧАЛКА
- (KO) 상단 및 하단 수직 잠금대용 가이드
- (SRB) VODICA ZA GORNJU I DONJU ŠIPKU VERTIKALNE BRAVE

Art.	ROD	1pc		CODE
		kg	pcs	
TL 50	TL 30/TL 40	0,01	4	1700152

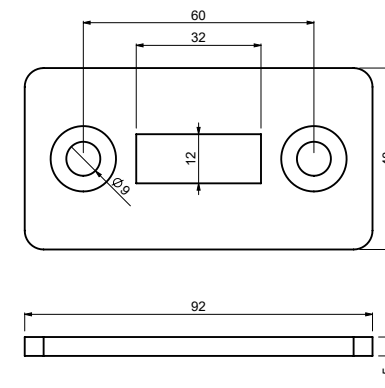
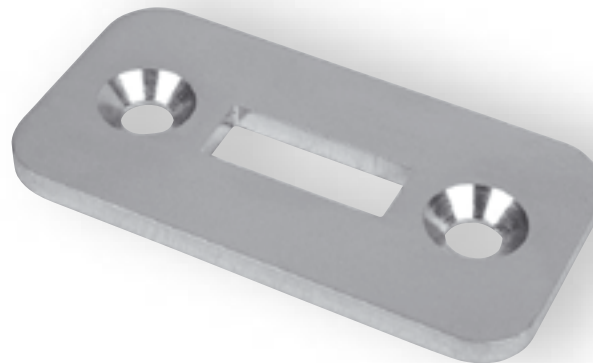

- (GB) END STOP FOR LOWER VERTICAL LOCKING ROD
- (D) BODENHALTERUNG FÜR TORSTANGE
- (F) BUTÉE POUR TIGE DE FERMETURE VERTICALE INFÉRIEURE
- (E) TOPE FINAL PARA VARILLA DE BLOQUEO VERTICAL INFERIOR
- (P) BATENTE PARA HASTE DE TRAVAMENTO VERTICAL INFERIOR
- (I) FERMO DI FINE CORSA PER ASTA DI BLOCCAGGIO VERTICALE INFERIORE
- (DK) ENDESTOP TIL NEDERSTE VERTIKALE LÅSESTANG
- (NL) EINDSTOP VOOR ONDERSTE VERTICALE SLUITSTANG
- (N) ENDESTOPPER FOR NEDRE VERTIKALE LÅSESTANG
- (S) ÄNDSTOPP FÖR NEDRE VERTIKAL LÅSSTÅNG
- (FIN) PÄÄTYPYSÄYTIN ALEMPÄÄN PYSTYSUORAAN LUKITUSVARTEEN
- (PL) OGRANICZNIK DOLNEGO PIONOWEGO PRĘTA BLOKUJĄCEGO
- (SK) ZÁPADKA PRE SPODNÚ TYČ
- (EE) OTSALÕPP ALUMISE VERTIKAALSE LUKUSTUSVARDA JAOKS
- (LT) VIRŠUTINIO VERTIKALIAUS UŽRAKTO STRYPO GALINIS RIBOKLIS
- (LV) GALA AIZTURIS VERTIKĀLAM APAKŠĒJAM FIKSĒŠANAS STIENIM

- (CZ) ZÁPADKA PRO TYČ SPODNÍ
- (RO) OPRITOR DE CURSĂ PENTRU TIJA DE BLOCARE INFERIOARĂ VERTICALĂ
- (HR) GRANIČNIK ZA DONJU ŠIPKU VERTIKALNE BRAVE
- (RUS) УЛАВЛИВАТЕЛЬ НИЖНЕЙ ВЕРТИКАЛЬНОЙ ЗАКРЫВАЮЩЕЙ РЕЙКИ
- (SLO) ZAUSTAVLJALNIK ZA SPODNJI VERTIKALNI ZAPORNI ZATIČ
- (TR) ALT DIKEY KİLITLEME ÇUBUĞU İÇİN UÇ TESPİT PARÇASI
- (AR) ممانع طرفي لقضيب القفل العمودي المنخفض
- (CHN) 下垂直锁杆终点挡块
- (MAL) PENYENDAL HUJUNG UNTUK ROD MENGUNCI TEGAK BAWAH
- (H) ÚTKÖZŐ AZ ALSÓ FÜGGŐLEGES ZÁR-RÚDHOZ
- (IL) מקבל לבריה עליון ותחתון
- (BG) СТОПЕР ЗА ДОЛЕН ЛОСТ ЗА ВЕРТИКАЛНА КЛЮЧАЛКА
- (KO) 하단 수직 잠금대용 종단 장치대
- (SRB) GRANIČNIK ZA DONJU ŠIPKU VERTIKALNE BRAVE

Art.	ROD	1pc		CODE
		kg	pcs	
TL 90	TL 30/TL 40	0,14	20	1700153

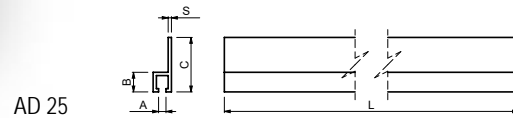

AD 25

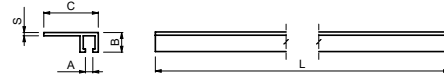

AS 25

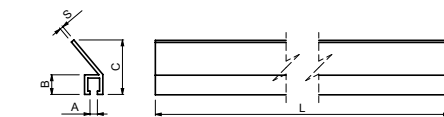

AR 25



- (GB) FORMED HOLDER FOR DOOR BRUSH SEALER
- (D) LEISTE FÜR AUFNAHME EINER BÜRSTE
- (F) SUPPORT PROFILÉ POUR BAS DE PORTE BROUSSE
- (E) SOPORTE PERFILADO PARA SELLADOR DE CEPILLO DE PUERTA
- (P) FIXADOR PARA SELADOR DA ESCOVA DA PORTA
- (I) SOSTEGNO CONFORMATO PER GUARNIZIONE A SPAZZOLA DELLA PORTA
- (DK) FORMET HOLDER TIL DØRBØRSTEFORSEGLER
- (NL) PROFIEL VOOR DEURBORSTEL
- (N) FORMET HOLDER TIL DØRBØRSTETÆTNING
- (S) FORMAD HÅLLARE FÖR DÖRRBORSTETÄTNING
- (FIN) MUOTOILTU PIDIKE OVIHARJAN TIIVISTEESSEN
- (PL) KSZTAŁTOWY UCHWYT SZCZOTKI USZCZELNIAJĄCEJ DRZWI
- (SK) LIŠŤA PRE FIXÁČIU TESNIAČEJ KEFY
- (EE) VORMITUD HOIDIK UKSE HARJASTEGA TIHENDI JAOKS
- (LT) SUFORMUOTAS ŠEPETINIO DURŲ SANDARIKLIO LAIKIKLIS
- (LV) PROFILĒTS TURETĀJS DURVJU SARU NOBLĪVĒJUMAM

- (CZ) LIŠŤA PRO FIXACI KARTÁČE
- (RO) SUPTOR MODELAT PENTRU ETANȘARE DE TIP PERIE A UȘII
- (HR) OBLIKOVANI DRŽAČ ČETKASTE TRAKE ZA VRATA
- (RUS) ПЛАНКА ДЛЯ КРЕПЛЕНИЯ ЩЕТКИ
- (SLO) PROFILIRANI NOSILEC ZA TESNILNO ŠČETKO ZA VRATA
- (TR) KAPI SÜPÜRGELİĞİ FITİLİ İÇİN ŞEKİLLENDİRİLMİŞ TUTAMAK
- (AR) الحامل المركب لمنع تسرب قشرة الباب
- (CHN) 门刷式密封异型座
- (MAL) PEMEGANG TERBENTUK UNTUK PENUTUP BERUS PINTU
- (H) RÓGZITÓPROFIL AZ AJTÓKEFÉS SZIGETELÉSHEZ
- (IL) מסילה למברשת
- (BG) ПЛАНКА ДЪРЖАЧ ЗА ЧЕТКА ЗА ВРАТА
- (KO) 도어 브러시 밀봉재용 성형식 홀더
- (SRB) OBLIKOVANI DRŽAČ ČETKASTE TRAKE ZA VRATA

Art.	C	A	B	S	L/1pc	BRUSH	1pc			CODE
							kg	pc	kg	
	mm									
AD 25/2	25	3,4	9	1,2	2000	BD 25/35/45	0,24	1	0,24	1700228
AD 25/1	25	3,4	9	1,2	1000	BD 25/35/45	0,12	1	0,12	1700154
AS 25/2	25	3,4	9	1,2	2000	BD 25/35/45	0,24	1	0,24	1700229
AS 25/1	25	3,4	9	1,2	1000	BD 25/35/45	0,12	1	0,12	1700155
AR 25/2	25	3,4	9	1,2	2000	BD 25/35/45	0,3	1	0,3	1700230
AR 25/1	25	3,4	9	1,2	1000	BD 25/35/45	0,15	1	0,15	1700199

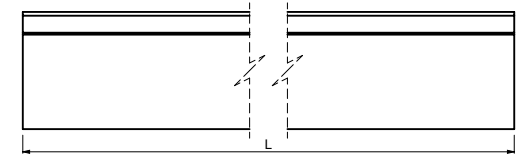
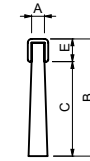

- (GB) DOOR BRUSH SEALER
- (D) ABDICHTBÜRSTE FÜR TÜREN UND TORE
- (F) BAS DE PORTE BROUSSE
- (E) SELLADOR DE CEPILLO DE PUERTA
- (P) SELADOR DA ESCOVA DA PORTA
- (I) GUARNIZIONE A SPAZZOLA DELLA PORTA
- (DK) DØRBØRSTEFORSEGLER
- (NL) DEURBORSTEL
- (N) DØRBØRSTETÆTNING
- (S) DÖRRBORSTETÄTNING
- (FIN) OVIHARJAN TIIVISTE
- (PL) SZCZOTKA USZCZELNIAJĄCA DO DRZWI
- (SK) TESNIAČA KEFA PRE UTESNENIE DVERÍ A BRÁN
- (EE) UKSE HARJASTEGA TIHEND
- (LT) ŠEPETINIS DURŲ SANDARIKLIS
- (LV) DURVJU SARU NOBLĪVĒJUMS

- (CZ) KARTÁČ PRO UTĚSNĚNÍ DVEŘÍ A VRAT
- (RO) ETANȘARE DE TIP PERIE A UȘII
- (HR) ČETKASTA TRAKA ZA VRATA
- (RUS) ЩЕТКА ДЛЯ УПЛОТНЕНИЯ ДВЕРЕЙ И ВОРОТ
- (SLO) TESNILNA ŠČETKA ZA VRATAE
- (TR) KAPI SÜPÜRGELİĞİ FITİLİ
- (AR) مانع تسرب قشرة الباب
- (CHN) 门刷式密封
- (MAL) PENUTUP BERUS PINTU
- (H) SZIGETELŐ AJTÓKEFE
- (IL) מברשת אטימה
- (BG) ЧЕТКА ЗА ВРАТА
- (KO) 도어 브러시 밀봉재
- (SRB) ČETKASTA TRAKA ZA VRATA

Art.	B	A	C	E	L/1pc	HOLDER	1pc			CODE
							kg	pc	kg	
	mm									
BD 25/2	30	5	25	5	2000	AD 25/AS 25/AR25	0,28	1	0,28	1700231
BD 25/1	40	5	25	5	1000	AD 25/AS 25/AR25	0,14	1	0,14	1700156
BD 35/2	50	5	35	5	2000	AD 25/AS 25/AR25	0,3	1	0,3	1700232
BD 35/1	30	5	35	5	1000	AD 25/AS 25/AR25	0,15	1	0,15	1700157
BD 45/2	40	5	45	5	2000	AD 25/AS 25/AR25	0,34	1	0,34	1700233
BD 45/1	50	5	45	5	1000	AD 25/AS 25/AR25	0,17	1	0,17	1700158

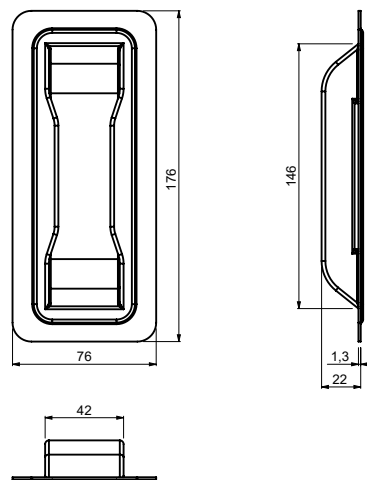

- (GB) EMBEDDED HANDLE
- (D) MUSCHELGRIF
- (F) POIGNÉE INTÉGRÉE
- (E) ASA INTEGRADA
- (P) MAÇANETA EMBUTIDA
- (I) MANIGLIA AD INCASSO
- (DK) INDSTØBT HÅNDTAG
- (NL) HANDVAT
- (N) INNEBYGD HÅNDTAK
- (S) INBYGGT HANDTAG
- (FIN) KOTELOITU KAHVA
- (PL) UCHWYT WPUSZCZANY
- (SK) MADLO ZAPUSTENÉ
- (EE) SISSESRUTUD KÄEPIDE
- (LT) ĮLEISTOJI RANKENA
- (LV) IESTRĀDĀTS ROKTURIS

- (CZ) MADLO ZAPUŠTĚNÉ
- (RO) MĂNER ÎNCASTRAT
- (HR) UPUŠTENI RUKOHVAT
- (RUS) РУЧКА УТОПЛЕННАЯ
- (SLO) UTOPNI ROČAJ
- (TR) GÖMÜLÜ KOL
- (AR) مقبض مدمج
- (CHN) 嵌入式把手
- (MAL) PEMEGANG TERBENAM
- (H) SÜLLYESZETT FOGANTYÚ
- (IL) ידית שקועה לדלת הזזה
- (BG) ДРЪЖКА ЗА ВКОПАН МОНТАЖ
- (KO) 내장식 손잡이
- (SRB) UPUŠTENA TUČKA

Art.	1pc			CODE
	kg	pcs	kg	
MS 40	0,17	20	3,4	1700145

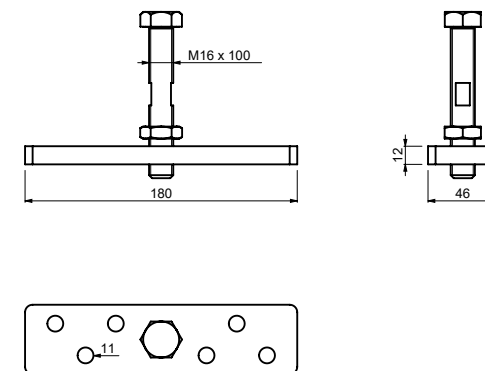

- (GB) UPPER ADJUSTABLE BRACKET SUPPORT FOR SLIDING DOOR
- (D) OBERE EINSTELLBARE HALTERUNGSSTÜTZE FÜR SCHIEBETÜR
- (F) SUPPORT SUPÉRIEUR RÉGLABLE POUR PORTAIL COULISSANT
- (E) SOPORTE AJUSTABLE SUPERIOR PARA PUERTA DESLIZANTE
- (P) SUPORTE DE SUPORTE AJUSTÁVEL SUPERIOR PARA PORTÃO DESLIZANTE
- (I) SOSTEGNO STAFFA SUPERIORE REGOLABILE PER PORTA SCORREVOLE
- (DK) ØVERSTE INDSTILLELIGE BESLAGSTØTTE TIL SKYDEDØR
- (NL) BOVENSTE VERSTELBARE BEVESTIGINGSBEUGELSTEUN VOOR SCHUIVENDE DEUR
- (N) ØVRE JUSTERBARE BRACKETSTØTTE FOR SKYVEDØR
- (S) ØVRE JUSTERBART KONSOLSTÖD FÖR SKJUTDÖRR
- (FIN) SÄÄDETTÄVÄ KANNATTIMEN YLÄTUKI LIUKUOVEEN
- (PL) GÓRNY REGULOWANY WSPORNIK DO DRZWI PRZESUWNYCH
- (SK) HORNÁ NASTAVITELNÁ KONZOLA PRE POSUVNÉ DVERE
- (EE) ÜLEMINE REGULEERITAV KLAMBRITUGI LIUGUKSE JAOKS
- (LT) VIRŠUTINĖ REGULIUJAMA LAIKIKLIO ATRAMA STUMDOMOSIOMS DURIMS
- (LV) REGULĒJAMS AUGŠĒJĀIS BALSTA KRONŠTEINS BĪDĀMAJĀM DURVĪM

- (CZ) DRŽÁK PRO POSUVNÉ VRATA
- (RO) SUPORT SUPERIOR REGLABIL ÎN CONSOLĂ PENTRU UȘI CULISANTE
- (HR) GORNJI PRILAGODLJIVI POTPORANJ NOSAČA ZA KLIZNA VRATA
- (RUS) ВЕРХНИЙ РЕГУЛИРУЕМЫЙ ОПОРНЫЙ КРОНШТЕЙН ДЛЯ РАМЫ ПАЗДВИЖНЫХ ДВЕРЕЙ
- (SLO) ZGORNJI NASTAVLJIVI PODPORNİ NOSILEC ZA DRSNĀ VRATA
- (TR) SÜRGÜLÜ KAPI İÇİN ÜST AYARLANABİLİR BRAKET DESTEĞİ
- (AR) سندة دعامة علوية قابلة للضبط للباب المنزلقي
- (CHN) 滑门可调节上部托臂托座
- (MAL) BANTUAN PENDAKAP BOLEH LARAS ATAS UNTUK PINTU GELONGSOR
- (H) FELSŐ ÁLLÍTHATÓ BEFOGÓELEM TOLÓAJTÓHOZ
- (IL) פחית תמיכה עליונה מתכווננת לדלתות הזזה
- (BG) ГОРНА РЕГУЛИРУЕМА ПОДДЪРЖАЩА СКОБА ЗА ПЛЪЗГАЩА ВРАТА
- (KO) 슬라이딩 도어용 상단 조절식 브래킷 지지대
- (SRB) GORNJI PODESIVI KONZOLNI NOSAČ ZA KLIZNA VRATA

Art.	1pc			CODE
	kg	pcs	kg	
GD 180	0,87	4	3,48	1700313

“THE PESSIMIST  
COMPLAINS ABOUT  
THE WIND. THE OPTIMIST  
EXPECTS IT TO CHANGE.  
THE LEADER ADJUST  
THE SAILS.”

“THE MEASURE  
OF INTELLIGENCE  
IS THE ABILITY  
TO CHANGE”

Albert Einstein –



## EASY SETS



16  
FOLLOW ME



18  
TWIN DRIVE



20  
CHEVRON



22  
HANGAR



24  
ALL IN ONE



## CANTILEVER SETS



26  
SOLE  
MARE  
VITA  
FERRO  
DINO  
ENZO  
DEMO



## CANTILEVER S



39  
STAGE SB



39  
STAGE SZ



40  
SPEED SE



40  
SPEED S



41  
SPEED SK



41  
RUN S



42  
LAST S



42  
PARK



42  
PARK 240



43  
PADDOCK SM



43  
PILOT SN



44  
PADDOCK 2



44  
PADDOCK 4



45  
FINISH S



45  
DIAGON 60



45  
DIAGON 80



46  
DESK SE



46  
DESK S



47  
DESK SK



47  
RAMP SE



48  
RAMP S



48  
RAMP SK



49  
CLINCH 16



49  
DRIVESHAFT 80



49  
DRIVESHAFT 100



## CANTILEVER M



57  
STAGE MB



57  
STAGE MZ



58  
SPEED ME



58  
SPEED M



59  
SPEED MEK



59  
RUN M



60  
LAST M



60  
PARK



60  
PARK 240



61  
PADDOCK SM



61  
PILOT M



61  
PILOT MN



62  
PADDOCK 2



62  
PADDOCK 4



63  
FINISH M



63  
DIAGON 60



63  
DIAGON 80



64  
DESK ME



64  
DESK M



65  
DESK MEK



65  
RAMP ME



66  
RAMP M



66  
RAMP MEK



67  
CLINCH 16



67  
DRIVESHAFT 80



67  
DRIVESHAFT 100



## CANTILEVER L



70  
STAGE LB



70  
STAGE LZ



71  
SPEED L



71  
PILOT L



71  
PILOT LN



72  
RUN L



72  
LAST L



73  
PARK L



73  
PARK L 350



73  
DRIVESHAFT 150



74  
PADDOCK L



74  
PADDOCK 6



75  
RAMP L































































































75  
CLINCH 16



# SLIDING GATE



# ACCESSORIES

	<b>78</b> TRAIL		<b>82</b> WV 1228 B2		<b>84</b> WTV 1024 B2		<b>87</b> WSO 1024		<b>88</b> RB 32		<b>92</b> SFB 42/16		<b>98</b> LOCK L		<b>102</b> LIMIT
	<b>78</b> PIN TRAIL		<b>82</b> WV 1430 B2		<b>85</b> WTO 625		<b>87</b> WSO 824 B2		<b>88</b> RB 42/16		<b>92</b> SFF 2M		<b>98</b> DOCK 42		<b>102</b> LIMIT S
	<b>79</b> ROAD		<b>82</b> WV 1630 B2		<b>85</b> WTO 825		<b>87</b> WSO 924 B2		<b>88</b> RB 42/20		<b>93</b> SFG 4M		<b>98</b> DOCK 52		<b>103</b> LIMIT M
	<b>79</b> PIN ROAD		<b>83</b> WO 824		<b>85</b> WTO 1024 B2		<b>87</b> WSO 1024 B2		<b>89</b> ROB 36		<b>93</b> CRANKSHAFT 220		<b>98</b> DOCK 62		<b>103</b> LIMIT H
	<b>80</b> VECTOR		<b>83</b> WO 924		<b>86</b> WSV 820		<b>87</b> WSO 1228 B2		<b>89</b> ROB 48		<b>93</b> CRANKSHAFT 440		<b>99</b> V/6		<b>104</b> ES 40
	<b>80</b> PIN VECTOR		<b>83</b> WO 1024		<b>86</b> WSV 920		<b>87</b> WSO 1630 B2		<b>89</b> ROB 68		<b>94</b> JRS 30		<b>99</b> S/6		<b>104</b> ES 50
	<b>81</b> VECTOR PACK		<b>83</b> WO 824 B2		<b>86</b> WSV 1020		<b>88</b> RW 26		<b>89</b> REB 36		<b>94</b> JRM 40		<b>99</b> Z/8		<b>104</b> ES 40 PN
	<b>82</b> WV 620		<b>83</b> WO 924 B2		<b>86</b> WSV 824 B2		<b>88</b> RW 30		<b>89</b> REB 48		<b>94</b> PRS 30		<b>99</b> Z/12		<b>104</b> ES 50 PN
	<b>82</b> WV 820		<b>83</b> WO 1024 B2		<b>86</b> WSV 924 B2		<b>88</b> RW 40		<b>89</b> REB 68		<b>94</b> PRM 40		<b>100</b> ROOF B		<b>105</b> END S
	<b>82</b> WV 920		<b>83</b> WO 1228 B2		<b>86</b> WSV 1024 B2		<b>88</b> RR 26		<b>90</b> SR 2		<b>95</b> DRIVER 38		<b>100</b> ROOF S		<b>105</b> END M
	<b>82</b> WV 1020		<b>83</b> WO 1430 B2		<b>86</b> WSV 1228 B2		<b>88</b> RR 30		<b>90</b> FRS 2		<b>95</b> DRIVER 48		<b>101</b> DUNE 2		<b>105</b> END L
	<b>82</b> WV 824 B2		<b>83</b> WO 1630 B2		<b>86</b> WSV 1630 B2		<b>88</b> RR 40		<b>90</b> FRM 2				<b>101</b> DUNE 2L		<b>105</b> END O
	<b>82</b> WV 924 B2		<b>84</b> WTV 624		<b>87</b> WSO 824		<b>88</b> RB 26		<b>91</b> GRS 4						
	<b>82</b> WV 1024 B2		<b>84</b> WTV 824		<b>87</b> WSO 924		<b>88</b> RB 30		<b>91</b> GRM 4						



# SWING GATES



# SLIDING DOORS

“YOU CAN DO  
ANYTHING  
IF YOU HAVE  
ENTHUSIASM”

– Henry Ford

“IF YOU ALWAYS  
DO WHAT YOU’VE  
ALWAYS DONE,  
YOU WILL ALWAYS  
GET WHAT  
YOU ALWAYS GOT”



EMIL  
TOMÁŠ  
DAVID  
STAŇA  
PEPI  
PAVEL  
HONZA

Grazie  
Děkuji  
Thank You



CEO  
MIRA CAIS  
JANA CAIS